

# **JAHNS**

---

## **HYDRAULIK**

### Radial Piston Motors series **HMF and HMT**

12. Edition January 2007



**Jahns-Regulatoren GmbH**

D 63069 Offenbach

D 63009 Offenbach

<http://www.jahns-hydraulik.de>

Spremlinger Landstraße 150

Postfach 100952

Phone +49 (0)69 848477-0

Fax +49 (0)69 84847725

[info@jahns-hydraulik.de](mailto:info@jahns-hydraulik.de)

# Table of Contents

## General Introduction to the Motors

Description of the Motors .....	3
Maximum Pressures .....	3
Operating Liquids .....	4
Installation and Operating Instructions .....	5

## Technical Specifications, Dimensions

### HMC series

Radial Piston Motor HMC-4500 to HMC-4500.....	6
---	---

### HMF series

Radial Piston Motor HMF-1006 to HMF-1030 .....	8
Radial Piston Motor HMF-1515 to HMF-1549 .....	10
Radial Piston Motor HMF-2030 to HMF-2097 .....	12
Radial Piston Motor HMF-2555 to HMF-2515 .....	14
Radial Piston Motor HMF-3078 to HMF-3020 .....	16
Radial Piston Motor HMF-3512 to HMF-3531 .....	18
Radial Piston Motor HMF-4026 to HMF-4047 .....	20

### HMT series

Radial Piston Motor HMT-1515 to HMT-1538 .....	22
Radial Piston Motor HMT-2030 to HMT-2076 .....	24
Radial Piston Motor HMT-2555 to HMT-2512 .....	26
Radial Piston Motor HMT-3078 to HMT-3017 .....	28
Radial Piston Motor HMT-3510 to HMT-3528 .....	30
Radial Piston Motor HMT-4026 to HMT-4039 .....	32

Distributor.....	34
Tachometers.....	36

© Jahns Regulatoren GmbH 1995, 1996, 1997, 2002, 2003, 2004, 2005, 2006, 2007

Reproduction of this document, including partial reproduction, is subject to our authorisation.

All information has been compiled and checked with great care. Nevertheless we assume no liability for incomplete or incorrect information.

Former editions of this catalogue are null and void. Subject to change

# General Introduction to the Motors

## Description

HM motors have a crankshaft operated by 5 or 7 pistons driven by oil pressure. This design is known for good breakaway torque, high torque even at low speeds, and high mechanical and volumetric efficiency. Furthermore this design offers some special advantages because of the way the cylinders and pistons are attached.

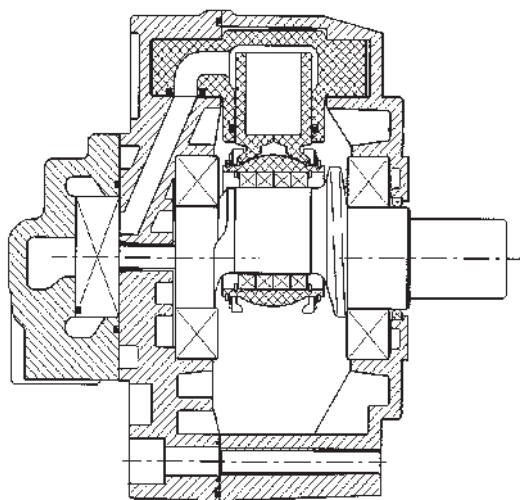

As can be seen in the section drawing, the cylinders are pivotally mounted in the motor case with laterally positioned bolts. During piston travel they position themselves in a way that the piston / cylinder axis always points to the eccentric centre. This eliminates pressure-induced shear force from the piston onto the cylinder wall and leads to lower friction forces and less cylinder wall wear. The cylinders are not part of the motor case and can therefore be manufactured from very hard and ductile materials at little cost.

As with the HMs and HMw series, the load on the slipper pads is mostly hydrostatically compensated. Furthermore, the pistons have no direct contact with the crankshaft, but push against a support ring with roller bearings, again minimising friction. This makes higher speeds as with the HMs and HMw series possible. At low speeds this prevents a stick-slip effect.

## Motor Sealing

All dynamic pressure zones of the motor in the control and piston area use a "seal ring + rotating ring" sealing system that allows for a certain readjustment capability and which does not produce high friction. This way the high efficiency of the motor is fully maintained for a

major part of their life time, provided the gaskets are not overly stressed by thermal load or dirt in the oil. Due to this sealing, the motor tolerates thermal shocks more easily, which can occur when too hot oil is filled in a still-standing, cold motor. Additionally, this form of sealing provides better protection against jamming due to dirt particles.

## Mechanical Piston to Crankshaft Connection

The pistons are retained by pull-out rings rather than by springs at the piston support ring. This prevents them from lifting off and suddenly hitting back on the shaft. The motors are thus more resistant to cavitation.

## Motor Characteristics

Data on power output, maximum peak and continuous pressure, and peak and continuous speeds can be found under the respective motor sizes. Especially the continuous operation characteristics have been kept low to allow for a wide range of applications. In particular cases, when application conditions are known, particularly for very infrequent operation, the rated values for continuous operation may be increased. We always ask you to discuss the intended application with us, so that we can choose the right motor for you. When you look at the tables you will notice that the same displacement can be found for different series. This will give you the possibility to choose between a longer bearing life expectancy and a cheaper version with a smaller outer diameter.

The bearing life expectancy, a possibility for theoretically calculating the life time, depends very much on the pressure and much less on the speed. If the pressure is reduced to half of the intended value, the life time increases tenfold! Reducing the speed to the half only doubles the life time. If the specific operating parameters are known, we can calculate the life expectancy for every motor for you. Experience shows that the calculated life expectancy will be affected by the rate oil temperatures rise and the extent of oil pollution as well as by carbon residue in continuous operation. But if the hydraulic system is ideally monitored, you may work without the following limitations:

Non-stop Dauerbetrieb in Stunden	<3	6	12	18	24
Faktor Verkürzung der Lebensdauer	1	1,25	1,5	2	3

# General Introduction to the Motors

## Maximum Shaft Load

Depending on the bearing that you select, the motors tolerate lower radial loads. Additionally, depending on the selected bearing they accept no or only small axial loads. In general, if there are considerable loads, we recommend using these motors in connection with our JPSM epicyclic gearings (see appropriate catalogue).

## Maximum Return Line Pressure

The motors can operate with high return line pressures as they occur, for instance when the motors are connected in series. The sum of the pressures at both connections can be approximately 360 bar; the motor can tolerate the sum of the peak pressures at the motor inlet and outlet to 700 bar.

## Leak Oil Pressure

The leak oil draining from the motor should not be under considerable pressure, even though a pressure preload up to 1.5 bar will not damage the unit. The peak pressure should be < 5 bar. Therefore, avoid connecting the motor leak oil to other leak oil drains with a single line. Especially valves can create short peaks in leak oil pressure, depending on pipe cross section, which could damage the shaft seal ring for example. Special motors with a maximum leak oil pressure up to 15 bar are available on request.

## Low-Speed

The motors are especially designed for running smoothly even at low speeds. In this case it is advantageous to preload the return line with 10 bar. The minimum speeds for all motors over 1000 cm<sup>3</sup>/rev range from 5 to 7 rpm. When driving high masses and for lower requirements concerning smooth running, the minimum speed is even lower.

## High-Speed

For higher speeds that exceed the standard ratings of the HMF motors, the new HMT series is available.

## Turning the Shaft Mechanically

The motors are capable of being mechanically turned at the shaft without much resistance, as it is the case when towing a hydraulically propelled vehicle or unwinding winches under a mechanical load. Then the allowed speed is even much higher than the rated maximum speed.

This free-wheeling operation works ideally when the motor is permanently supplied with enough oil for the driven parts inside the motor case due to leak oil preloading with a 0.3 to 0.5 bar check valve. The motor can also operate without any oil in the piston section. Therefore, the motor connectors should be connected to the air between the oil level in the reservoir and the reservoir ceiling for free-wheeling operation.

If there is oil in the pistons during free-wheeling operation, unpleasant rattle noise might occur, which is not harmful to the motor but nevertheless annoying.

## Motor Noise

One of the advantages of radial piston motors is the low noise level. An ideal noise level can be achieved if the return line is preloaded with 5 - 10 bar or the motor operates in a closed loop system.

## Connecting Motors in Series

The motors can be connected in series. Due to the low leak oil level, this type of connection provides excellent synchronisation of the motors, especially at high speeds. By switching between parallel and serial operation when using two motors, the speed may optionally be doubled for the same oil flow or the torque almost doubled. For the connection of two motors, Jahns offers the following circuitry accessories.

- Electrically activated flow divider valve for occasionally engaging a 'differential lock'. For this see our catalogue „Hydraulic Oil Flow Divider“.
- Flow divider valves that allow for motors to rotate at different speeds even when connected in series (differential effect), as it is necessary for vehicle propel operation.

## Hydraulic Operating Fluid

Even though we principally recommend using HLP mineral oils with an optimal viscosity of 40 to 80 cSt, viscosities of 20 to 150 cSt are within specifications as well.

In recent time a huge number of different synthetic and/or biodegradable operating fluids have become available on the market. It is not possible for us to test each of those fluids in order to issue certificates of compliance. Please contact the liquid manufacturers for references. If those companies can offer references for high-speed axial piston units, such as axial piston pumps, then those liquids are equally suited for our

## General Introduction to the Motors

motors. Any limitations stated in the references, such as the requirement for special sealing, apply to our motors as well.

The use of emulsion based operating fluids limits the operating parameters to the following values because of the relatively low lubricating power of those fluids:

Continuous pressure 150 bar

Speed 50 % of catalogue specifications

Operating temperature + 10°C to + 60° C

### Filtration

We recommend a filter mesh size of 25 µm or better.

### Leak Oil Discharge at the Motor

**Radial piston motors require the motor case to be filled with oil prior to first use!**

Do not think this is unnecessary just because oil is delivered to the motor by the oil lines!! Most Jahns' motors feature a minimal internal and external oil leakage, therefore motors not filled prior to use run more or less 'dry' for hours, before they are filled by their own leak oil, especially during depressurized first use operation! The leak oil line is to be connected to the labelled leak oil ports of the motors; and at one point before reaching the reservoir, the level of the line has to be higher than the motor level.

If the reservoir is above motor level, the use of a 0.5 bar check valve in the front of the leak oil port is recommended. This small leak oil pressure does not pose any problems, yet the check valve prevents oil from leaking into the environment when the leak oil line is disconnected.

Do not try to achieve this effect by the use of isolation valves, since it is easy to forget to open such valves..

If the motors are removed from the machine, e.g. because of repair work, and have been drained, then they have to be filled again before further operation.

Especially when motors are mounted with their output shaft pointing upwards, suitable measures have to be taken to ensure that the front bearing is lubricated as well!

### Pressure Lines

Select the lines according to the instructions of the pipe manufacturers regarding allowable maximum

pressure and pipe cross-section. In order to avoid oil compressibility to the extent possible and with regard to pressure oscillations, the lines should be as short as possible.

New piping is often a source for dirt entering the hydraulic system because of material particles, lack of trimming, lack of descaling of welded pipes etc. In order to ensure maximum cleanliness, we recommend flushing the oil system with fresh oil.

During the first hours of operation the pipes should be checked for leakage.

### Improper Handling of the Motors

The cost-efficient and light design of the units means that the motors are deliberately equipped with motor cases that are not fit for the units being thoughtlessly dropped to the ground, for driving them out of their centring device by applying force, or for trying to align motors seated unaligned in their centring devices by forcefully pulling on their fixing screws.

The components activated by the motors should not have any angular or axial offsets which push against the motor shaft. The motor shaft should especially not be pushed axially nor should couplings, flanges, etc. be driven on the shaft with a hammer.

If angular or axial offsets cannot be avoided, we have a motor solution available that allows for a pure shaft coupling with torque support.

# Radial Piston Motor HMC-45..

All motors of the HMC-45.. series come with spherical roller bearing, multiple spline shaft to DIN 5480 and the J30 control.  
For other controls see pages 34 and 35.  
For notes on function, installation and start-up of the hydraulic motors please refer to page 3 to 5.

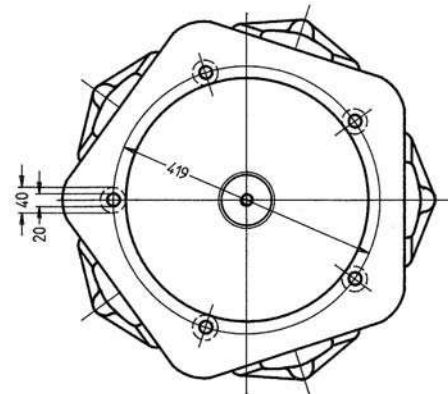
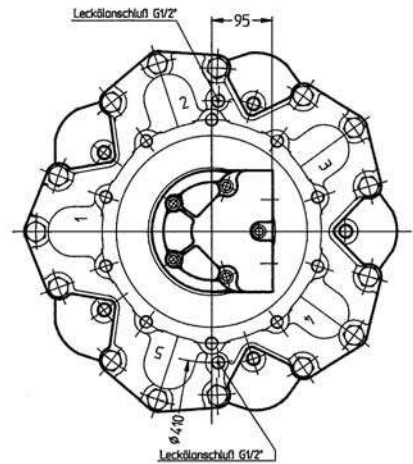
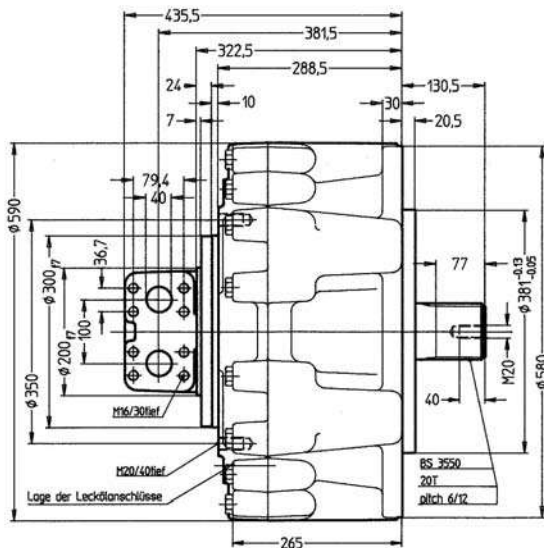

symbol DIN ISO 1219



Weight approx.	300	kg
Mass moment of inertia	0,103	kgm <sup>2</sup>
Oil volume in motor case litres	21	litres

## Model code

e.g. **HMC - 4546 - V C - J30/1 - TW**

**Series**

**nominal size**

**Output shafts**

- W = multiple spline shaft
- N = multiple spline hollow shaft
- P = cylindrical feather key shaft
- K = tapered feather key shaft

**Storage**

- C = spherical roller bearing

**Tachogenerator**

- TW = tachometer shaft Ø 6 mm
- T.. = tachogenerator

models starting on page 36

**Control**

# Radial Piston Motor HMC-45..

Nominal size		4531	4538	4546	4556	4567
Displacement	cm <sup>3</sup> /Umdr	2042	2471	2985	3611	4298
Specific theor. torque	Nm/bar	31,9	38,6	46,6	56,4	67,1
Peak pressure	bar	420	420	420	420	420
Continuous pressure	bar	250	250	250	250	250
Max. speed	U/min	280	260	220	200	170
Continuous speed	U/min	180	170	140	130	110
Max. power output	kW	110	130	150	190	220
Continuous power output	kW	55	65	75	95	110

## Output shafts

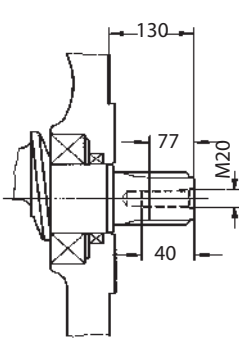
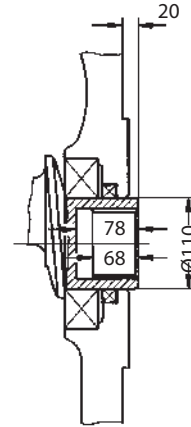
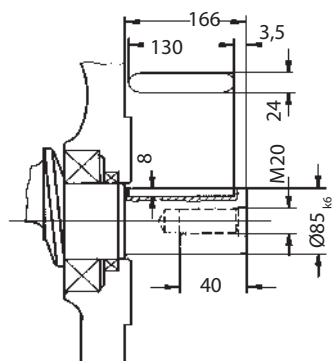
W = 80x3x25, DIN 5480 V = BS 3550 20T pitch 6/12	N = 80x3x25, DIN 5480	P=cylindrical feather key shaft
		

## Diagrams

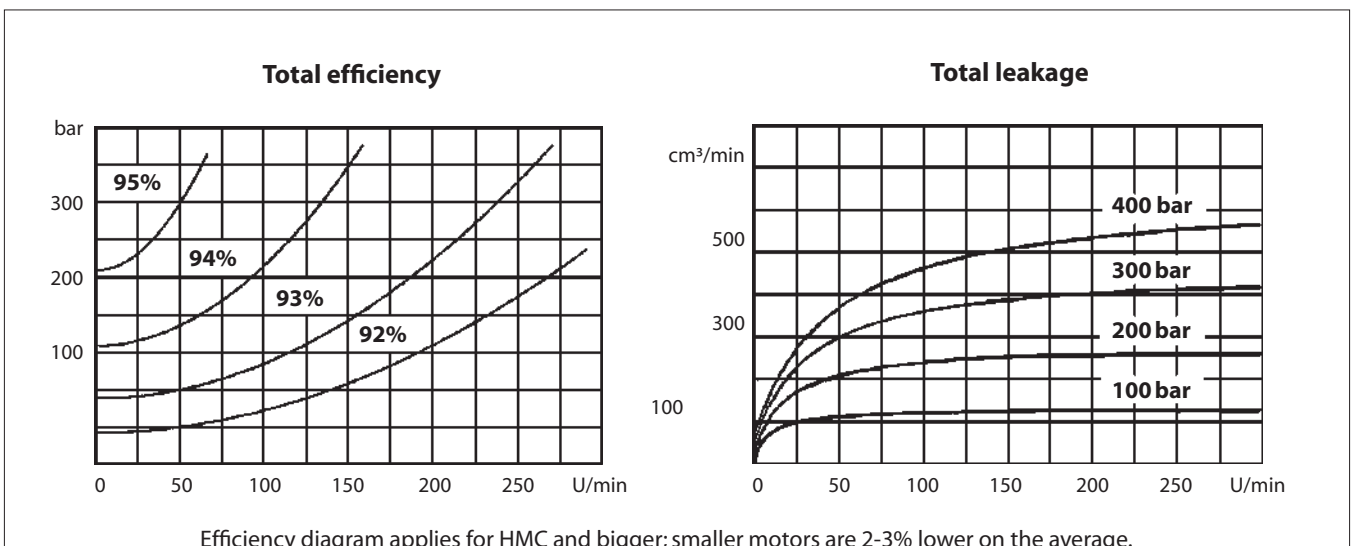

# Radial Piston Motor HMF-10..

All motors of the HMF-10.. series come with roller bearing, multiple spline shaft to DIN 5463 and the J20 control. For other controls see pages 34 and 35.

For notes on function, installation and start-up of the hydraulic motors please refer to page 3 to 5.

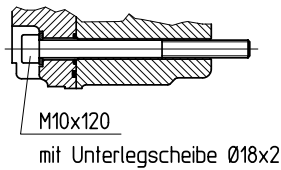
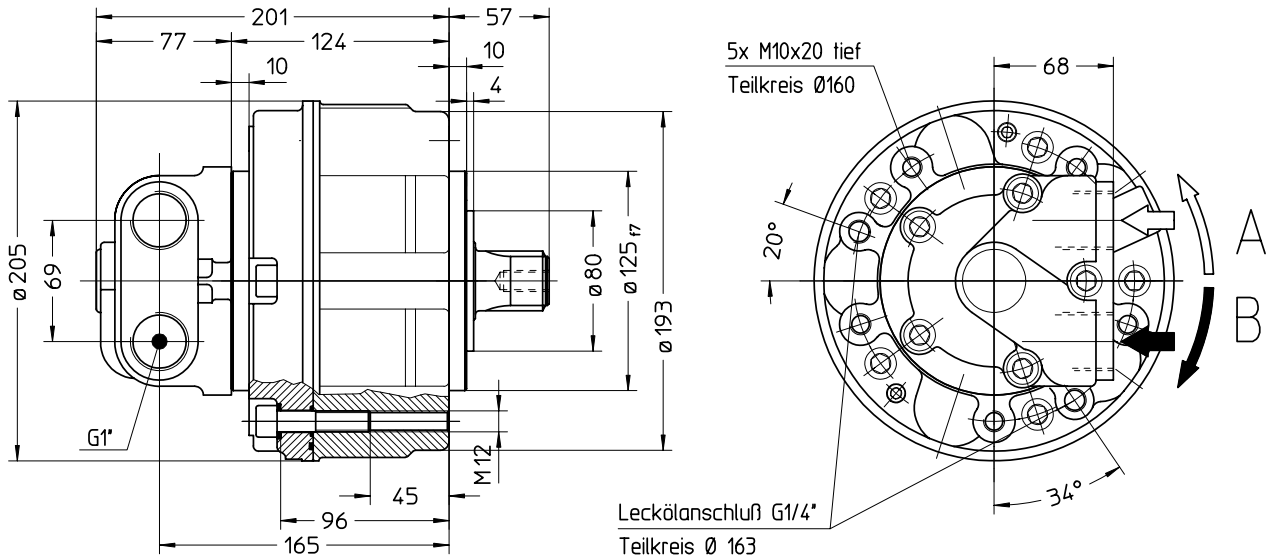

Weight approx. 22 kg  
 Mass moment of inertia 0,00009 kgm<sup>2</sup>  
 Oil volume in motor case litres 0,8 litres

symbol DIN ISO 1219

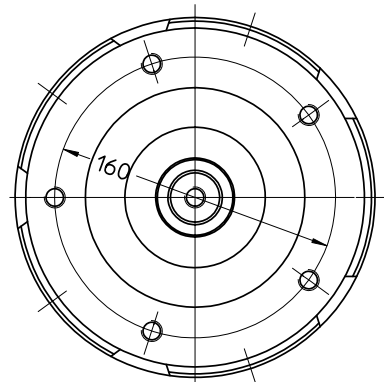

## Model code

e.g. **HMF - 1020 - V A - J20/1 - TW**

### Series

### nominal size

### Output shafts

- V** = multiple spline shaft DIN 5463
- W** = multiple spline shaft DIN 5480
- H** = multiple spline hollow shaft DIN 5463
- N** = multiple spline hollow shaft DIN 5480
- K** = tapered feather key shaft
- P** = feather key shaft

### Storage

- A** = roller bearing
- B** = ball bearing

### Tachogenerator

- TW** = tachometer shaft Ø 6 mm
- T** = tachogenerator
- models starting on page 36

### Control

- J20** = pressure connection G1"
- /1** = alignment to cylinder 1
- models starting on page 34



# Radial Piston Motor HMF-10..

Nominal size		1006	1009	1011	1013	1017	1020	1023	1026	1030
Displacement	cm <sup>3</sup> /Umdr	39	59	74	86	115	129	151	166	191
Specific theor. torque	Nm/bar	0,6	0,9	1,1	1,3	1,8	2,0	2,4	2,6	3,0
Peak pressure	bar	350	350	350	350	350	350	325	325	280
Continuous pressure	bar	250	250	250	250	250	250	250	250	250
Max. speed	U/min	1000	1000	1000	1000	900	900	900	800	800
Continuous speed	U/min	700	700	700	650	650	600	600	550	550
Max. power output	kW	15	15	15	20	20	20	20	20	20
Continuous power output	kW	10	10	10	15	15	15	15	15	15

## Output shafts

V = 6-28-34	DIN 5463	H = 6-28-34	DIN 5463	K = tapered feather key shaft	P = cylindrical feather key shaft
W = 35x2x16	DIN 5480	N = 35x2x16	DIN 5480		

The technical drawings show four shaft configurations:
 

- V**: Standard shaft with dimensions 57, 22, M12, 26.
- H**: Shaft with a diameter of 23 and a bore diameter of 45.
- K**: Tapered shaft with a taper of 1:10, dimensions 57, 35, 4, 14, 6, M16, 32, and a bore diameter of 45.
- P**: Cylindrical shaft with dimensions 65, 45, 3, 8, M8, 26, and a bore diameter of 30.

## Diagrams

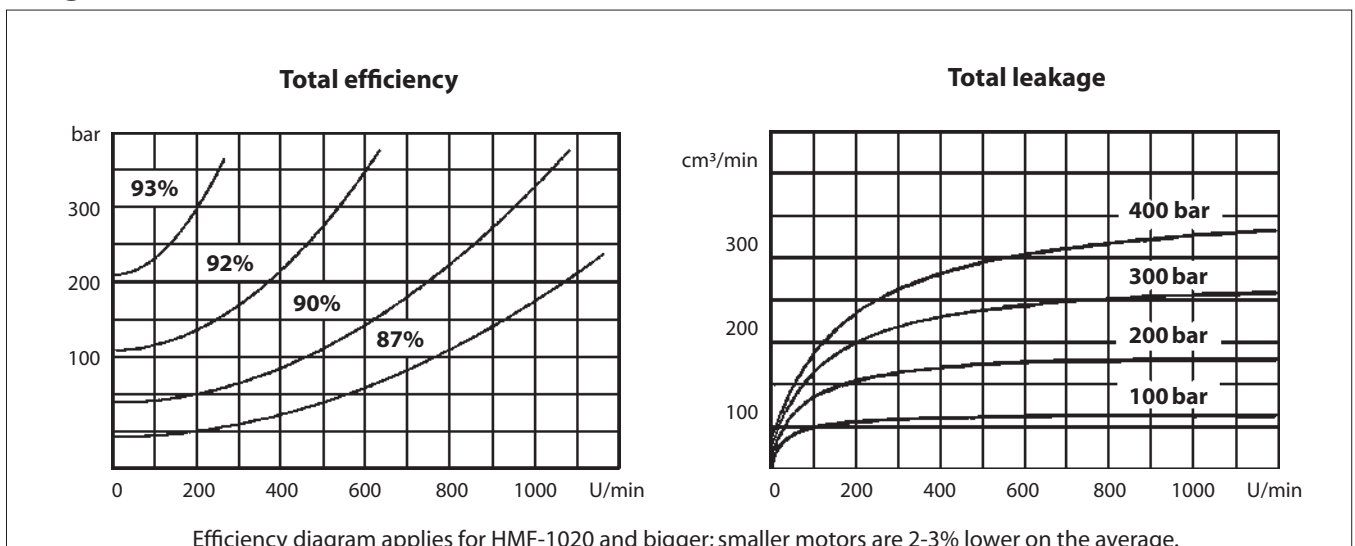

# Radial Piston Motor HMF-15..

All motors of the HMF-15.. series come with roller bearing, multiple spline shaft to DIN 5463 and the J20 control. For other controls see pages 34 and 35.

For notes on function, installation and start-up of the hydraulic motors please refer to page 3 to 5.

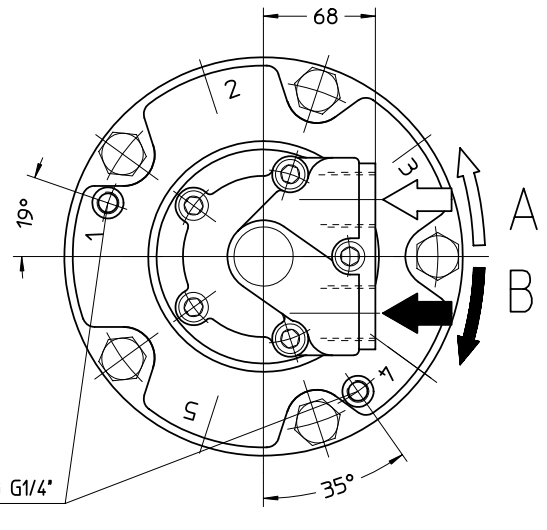
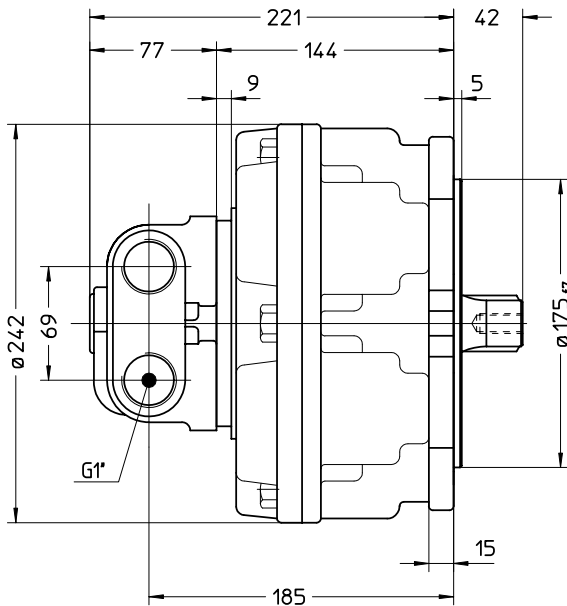

symbol DIN ISO 1219

Weight approx.  
Mass moment of inertia  
Oil volume in motor case litres

30 kg  
0,0013 kgm<sup>2</sup>  
1,0 litres

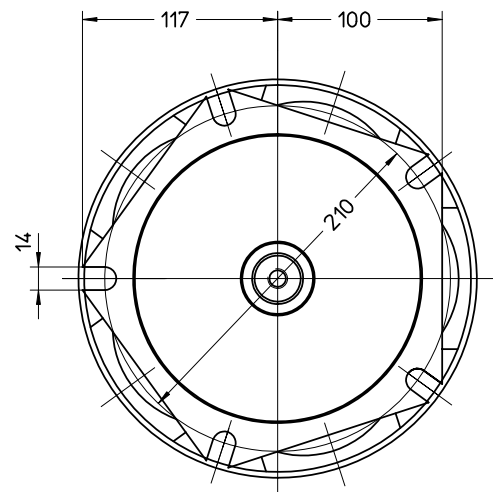

## Model code

e.g. **HMF - 1524 - V A - J20/1 - TW**

### Series

### nominal size

### Output shafts

- W = multiple spline shaft DIN 5480
- V = multiple spline shaft DIN 5463
- N = multiple spline hollow shaft DIN 5480
- H = multiple spline hollow shaft DIN 5463
- K = tapered feather key shaft
- P = feather key shaft

### Storage

- A = roller bearing
- B = ball bearing

### Tachogenerator

- TW = tachometer shaft Ø 6 mm
  - T = tachogenerator
- models starting on page 36

### Control

- J20 = pressure connection G1"
  - 1 = alignment to cylinder 1
- models starting on page 34

# Radial Piston Motor HMF-15..

Nominal size		1515	1517	1524	1526	1531	1535	1538	1545	1549
Displacement	cm <sup>3</sup> /Umdr	99	129	154	172	201	221	243	290	314
Specific theor. torque	Nm/bar	1,5	1,7	2,4	2,6	3,1	3,5	3,7	4,5	4,9
Peak pressure	bar	400	400	400	350	350	350	350	300	280
Continuous pressure	bar	250	250	250	250	250	250	250	250	250
Max. speed	U/min	1000	1000	900	800	800	700	600	600	500
Continuous speed	U/min	550	550	550	500	500	450	450	350	350
Max. power output	kW	30	30	30	30	30	30	30	30	30
Continuous power output	kW	20	20	20	20	25	25	25	25	25

## Output shafts

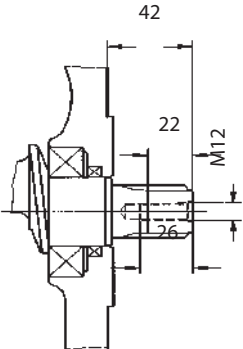
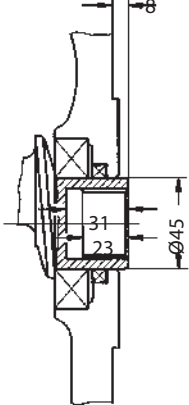
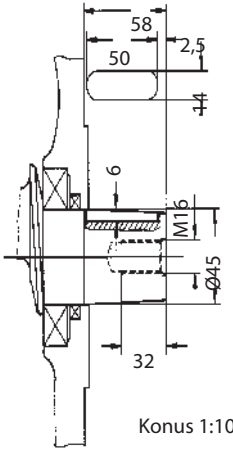
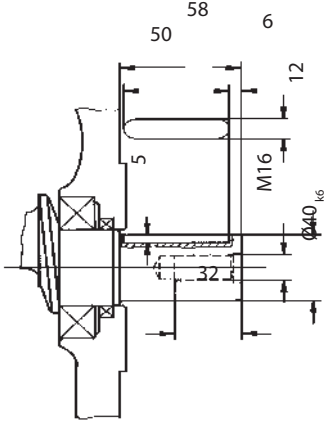
V = 6-28-34 DIN 5463	H = 6-28-34 DIN 5463	K = tapered feather key shaft	P = cylindrical feather key shaft
W = 35x2x16 DIN 5480	N = 35x2x16 DIN 5480		
			

## Diagrams

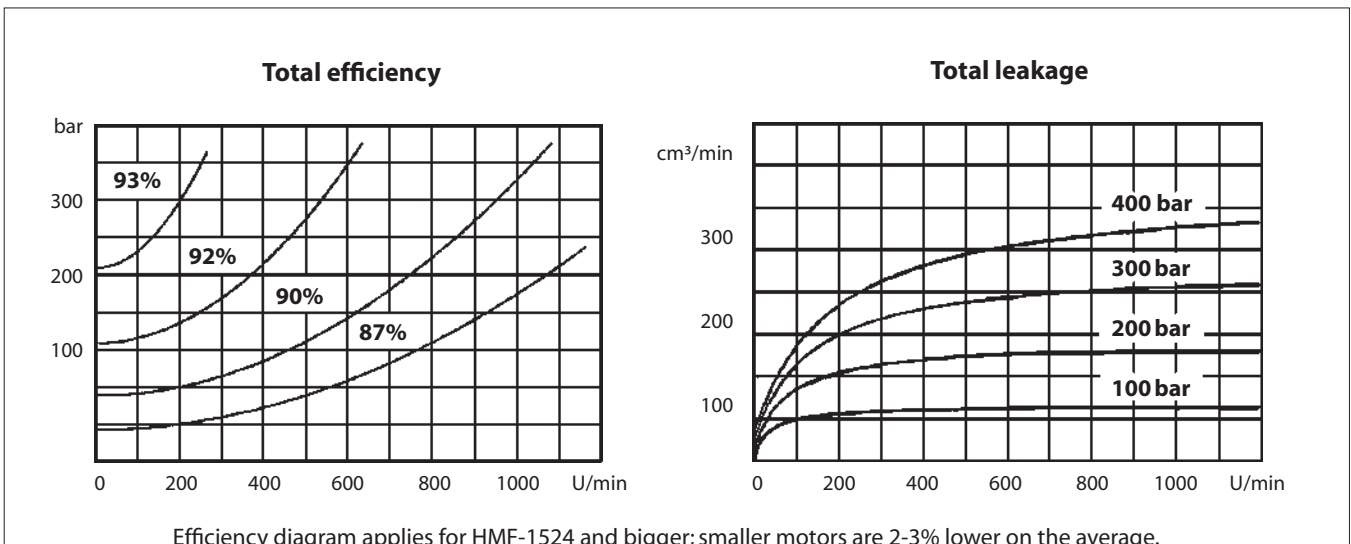



# Radial Piston Motor HMF-20..

Nominal size		2030	2039	2047	2054	2066	2076	2088	2097
Displacement	cm <sup>3</sup> /Umdr	192	251	304	347	425	493	565	623
Specific theor. torque	Nm/bar	3,0	3,9	4,7	5,4	6,6	7,6	8,8	9,7
Peak pressure	bar	400	400	400	350	350	350	300	280
Continuous pressure	bar	250	250	250	250	250	250	250	250
Max. speed	U/min	750	750	750	700	700	700	650	600
Continuous speed	U/min	500	500	500	450	450	450	425	400
Max. power output	kW	40	40	40	40	40	40	40	40
Continuous power output	kW	30	30	30	35	35	35	35	35

## Output shafts

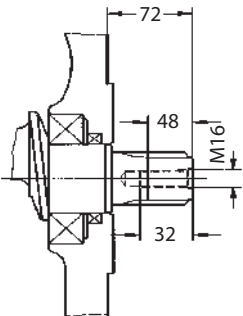
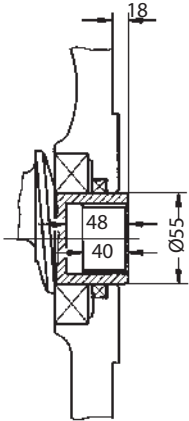
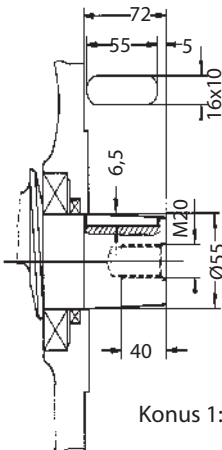
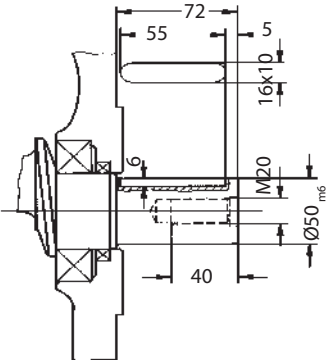
V = 8-36-40 DIN 5462	H = 8-36-40 DIN 5462	K = tapered feather key shaft	P = cylindrical feather key shaft
W = 40x3x12 DIN 5480	N = 40x3x12 DIN 5480		
			

## Diagrams

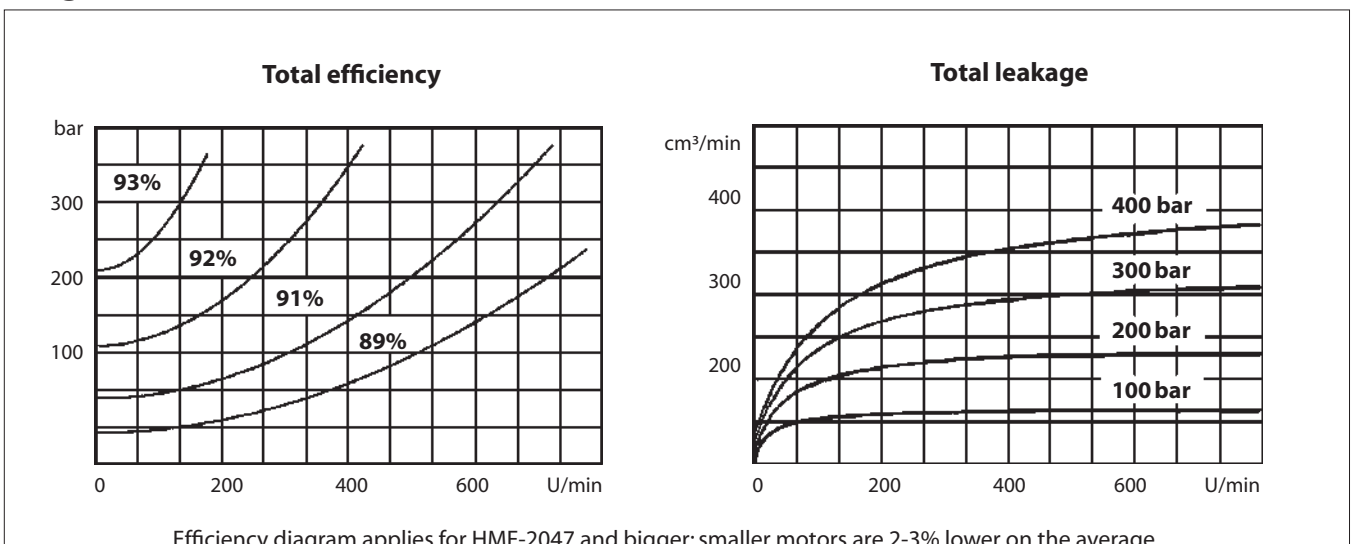

# Radial Piston Motor HMF-25..

All motors of the HMF-25.. series come with roller bearing, multiple spline shaft to DIN 5463 and the J20 control. For other controls see pages 34 and 35.

For notes on function, installation and start-up of the hydraulic motors please refer to page 3 to 5.

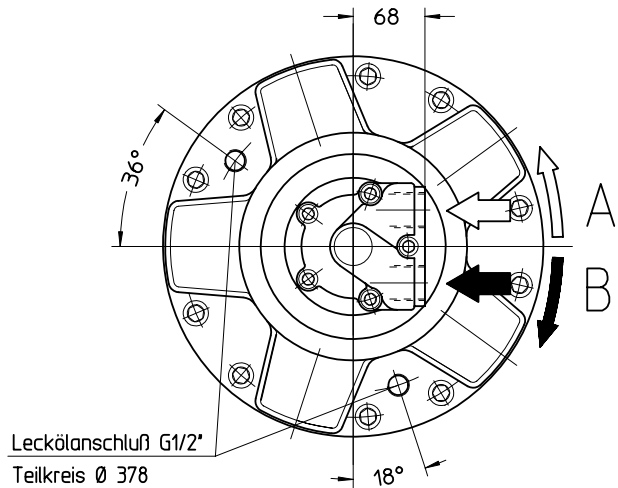
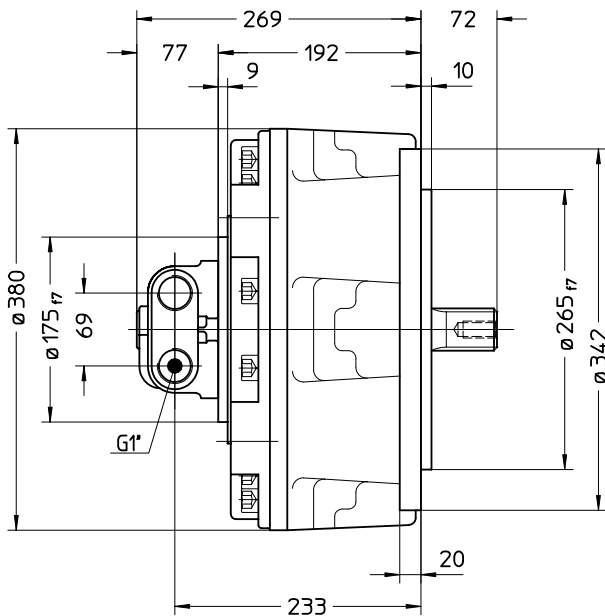

symbol DIN ISO 1219

Weight approx. 86 kg  
 Mass moment of inertia 0,0046 kgm<sup>2</sup>  
 Oil volume in motor case litres 4,5 litres

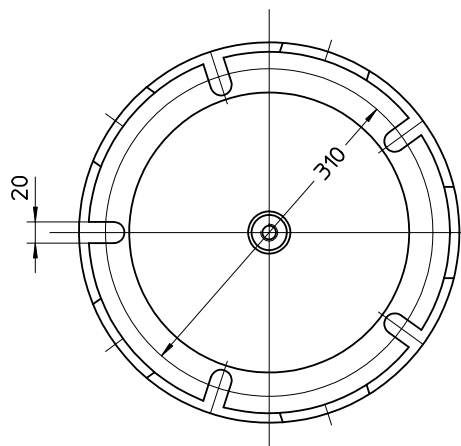

## Model code

e.g. **HMF - 2576 - V A - J20/1 - TW**

**Series**

**nominal size**

**Output shafts**

- W** = multiple spline shaft DIN 5480
- V** = multiple spline shaft DIN 5463
- N** = multiple spline hollow shaft DIN 5480
- H** = multiple spline hollow shaft DIN 5462
- K** = tapered feather key shaft
- P** = feather key shaft

**Storage**

- A** = roller bearing
- CH** = spherical roller bearing in motor cover  
roller bearing in motor body

## Tachogenerator

- TW** = tachometer shaft Ø 6 mm
- T** = tachogenerator  
models starting on page 36

## Control

- J20** = pressure connection G1"
- /1** = alignment to cylinder 1  
models starting on page 34

# Radial Piston Motor HMF-25..

Nominal size		2555	2566	2576	2593	2511	2512	2513	2515
Displacement	cm <sup>3</sup> /Umdr	352	426	486	595	690	792	873	987
Specific theor. torque	Nm/bar	5,4	6,6	7,5	9,2	10,7	12,3	13,6	15,4
Peak pressure	bar	425	425	425	400	350	350	350	280
Continuous pressure	bar	250	250	250	250	250	250	250	250
Max. speed	U/min	670	620	580	550	480	480	390	350
Continuous speed	U/min	525	500	450	450	400	400	350	300
Max. power output	kW	45	45	45	50	50	50	50	50
Continuous power output	kW	35	35	35	40	40	40	40	40

## Output shafts

V = 8-46-54 W = 40x3x12	DIN 5463 DIN 5480	H = 8-36-40 N = 40x3x12	DIN 5462 DIN 5480	K = tapered feather key shaft	P = cylindrical feather key shaft		

## Diagrams

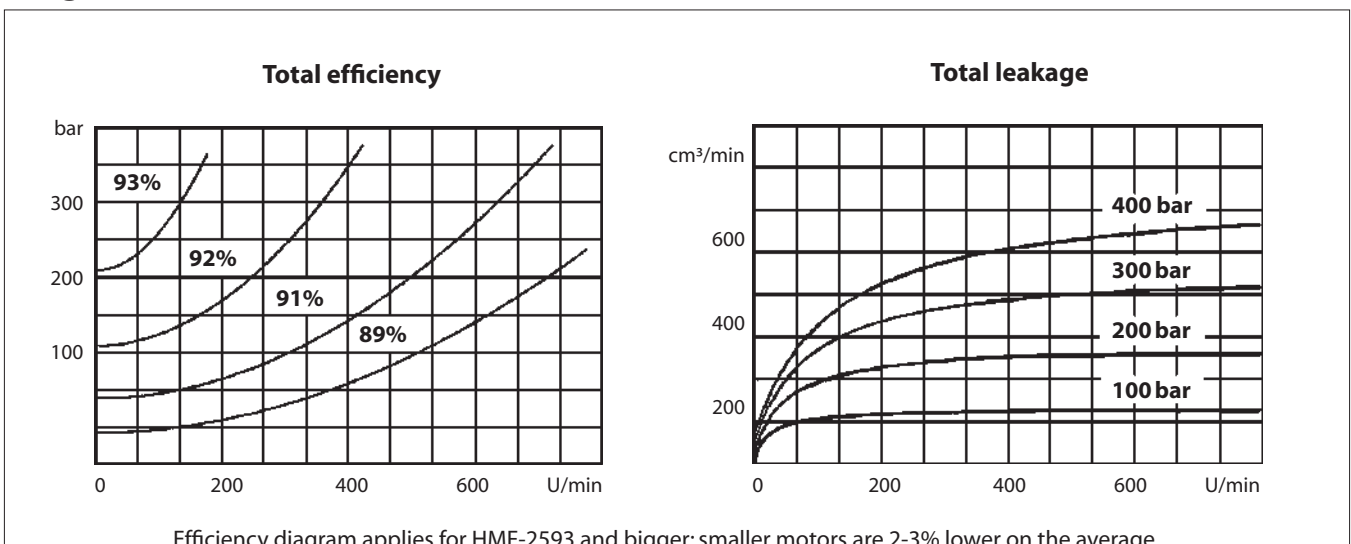

# Radial Piston Motor HMF-30..

All motors of the HMF-30.. series come with roller bearing, multiple spline shaft to DIN 5463 and the J20 control. For other controls see pages 34 and 35.

For notes on function, installation and start-up of the hydraulic motors please refer to page 3 to 5.

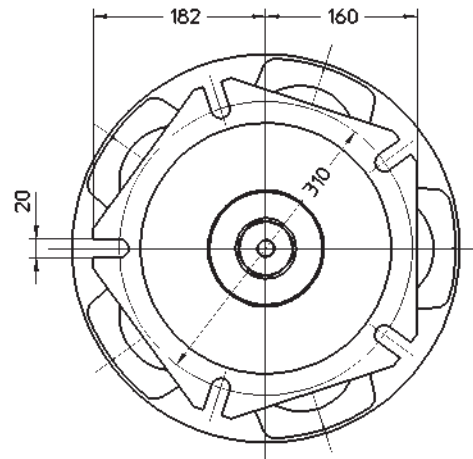
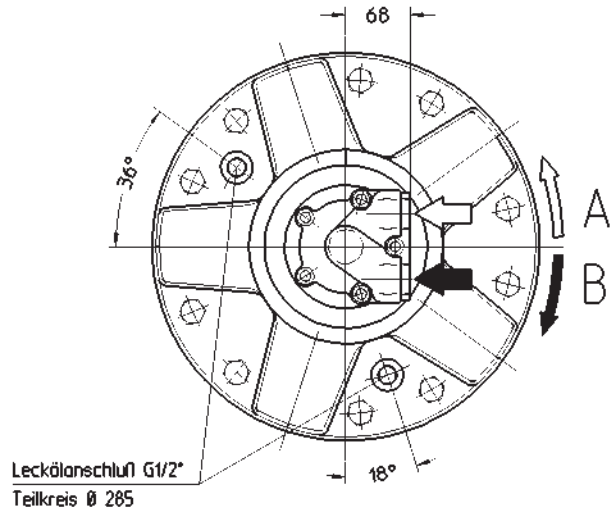
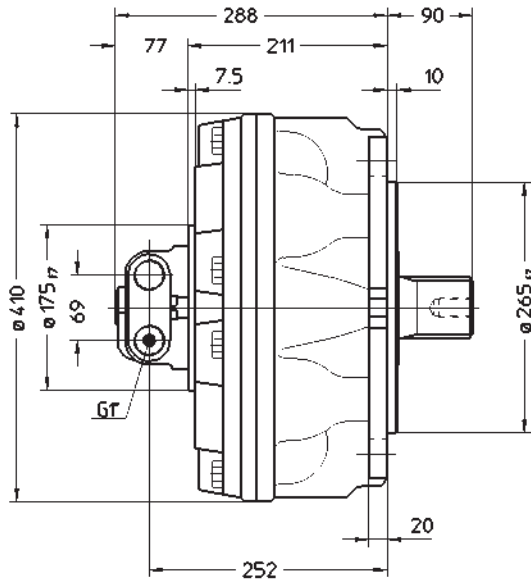

symbol DIN ISO 1219



Weight approx. 110 kg  
 Mass moment of inertia 0,0172 kgm<sup>2</sup>  
 Oil volume in motor case litres 6,5 litres

## Model code

e.g. **HMF - 3012 - V A - J20/1 - TW**

**Series**

**nominal size**

**Output shafts**

- W** = multiple spline shaft DIN 5480
- V** = multiple spline shaft DIN 5463
- N** = multiple spline hollow shaft DIN 5480
- H** = multiple spline hollow shaft DIN 5482
- K** = tapered feather key shaft
- P** = feather key shaft

**Storage**

- A** = roller bearing
- C** = spherical roller bearing

**Tachogenerator**

- TW** = tachometer shaft  $\varnothing 6$  mm
  - T** = tachogenerator
- models starting on page 36

**Control**

- J20** = pressure connection G1"
  - /1** = alignment to cylinder 1
- models starting on page 34



# Radial Piston Motor HMF-30..

Nominal size		3062	3078	3096	3010	3012	3014	3016	3017	3019	3020
Displacement	cm <sup>3</sup> /Umdr	402	503	616	714	793	904	1022	1116	1247	1316
Specific theor. torque	Nm/bar	6,2	7,8	9,6	10,5	12,4	14,1	16	17,4	19,5	20,5
Peak pressure	bar	400	400	350	350	350	320	320	320	280	280
Continuous pressure	bar	250	250	250	250	250	250	250	250	250	250
Max. speed	U/min	550	550	500	500	450	450	400	350	350	350
Continuous speed	U/min	425	425	400	400	350	325	300	275	250	225
Max. power output	kW	60	60	60	60	70	70	70	80	80	80
Continuous power output	kW	40	40	40	40	45	45	45	50	50	50

## Output shafts

V = 8-56-65 W = 65x3x20	DIN 5463 DIN 5480	H = A 55x50 N = 55x3x17	DIN 5482 DIN 5480	K = tapered feather key shaft	P = cylindrical feather key shaft		

## Diagrams

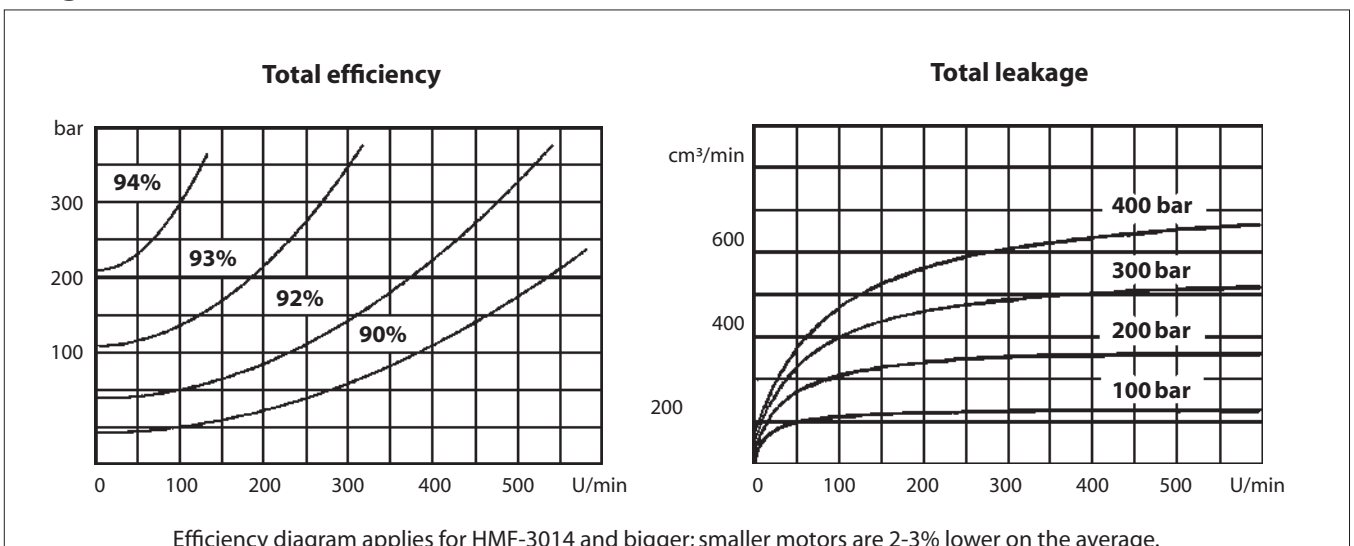

# Radial Piston Motor HMF-35..

All motors of the HMF-35.. series come with roller bearing, multiple spline shaft to DIN 5463 and the J20 control. For other controls see pages 34 and 35.

For notes on function, installation and start-up of the hydraulic motors please refer to page 3 to 5.

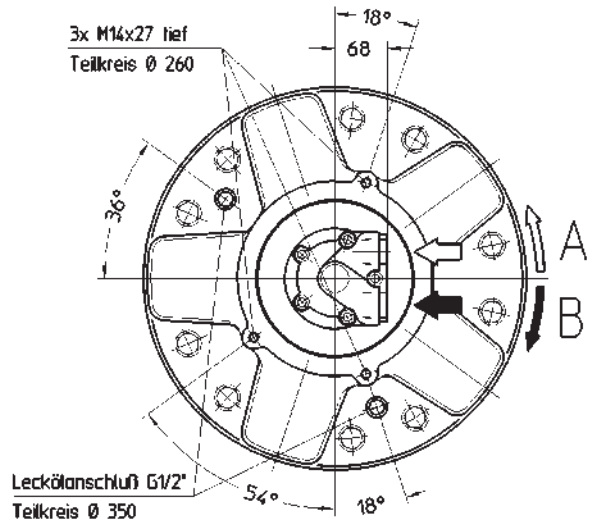
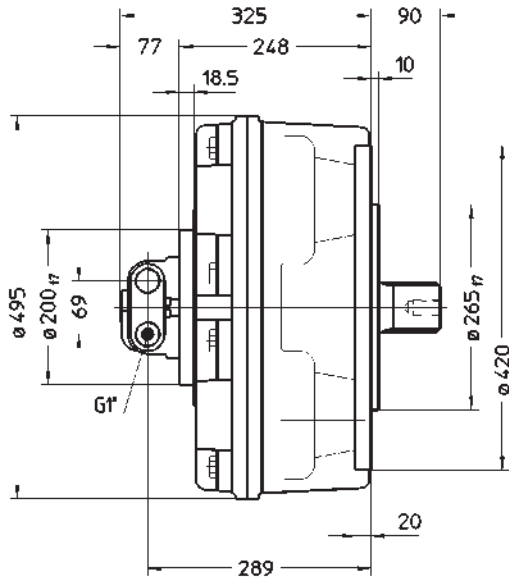

symbol DIN ISO 1219



Weight approx. 170 kg  
 Mass moment of inertia 0,0277 kgm<sup>2</sup>  
 Oil volume in motor case litres 10 litres

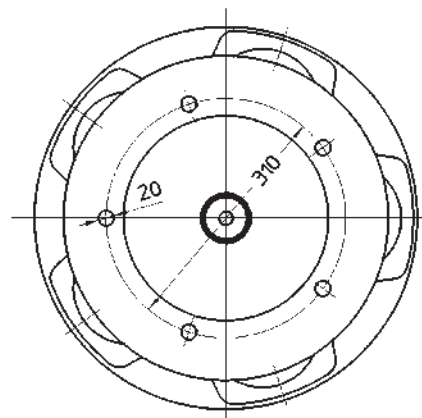

## Model code

e.g. **HMF - 3520 - V A - J20/1 - TW**

**Series**

**nominal size**

**Output shafts**

- W** = multiple spline shaft DIN 5480
- V** = multiple spline shaft DIN 5463
- N** = multiple spline hollow shaft DIN 5480
- H** = multiple spline hollow shaft DIN 5482
- K** = tapered feather key shaft
- P** = feather key shaft

**Storage**

- A** = roller bearing
- C** = spherical roller bearing

**Tachogenerator**

- TW** = tachometer shaft Ø 6 mm
  - T** = tachogenerator
- models starting on page 36

**Control**

- J20** = pressure connection G1"
  - /1** = alignment to cylinder 1
- models starting on page 34

# Radial Piston Motor HMF-35..

Nominal size		3508	3510	3512	3516	3518	3520	3522	3525	3528	3531
Displacement	cm <sup>3</sup> /Umdr	526	659	807	1039	1185	1340	1462	1634	1816	2007
Specific theor. torque	Nm/bar	8,2	10,2	12,6	16,2	18,5	20,9	22,8	25,5	28,3	31,3
Peak pressure	bar	400	400	400	400	400	350	350	350	350	350
Continuous pressure	bar	250	250	250	250	250	250	250	250	250	250
Max. speed	U/min	450	450	400	400	350	350	300	300	250	250
Continuous speed	U/min	300	300	250	250	225	225	200	200	175	175
Max. power output	kW	80	80	90	90	100	100	100	100	100	100
Continuous power output	kW	40	40	45	45	55	55	55	55	55	55

## Output shafts

V = 8-56-65 DIN 5463	H = A 55x50 DIN 5482	K = tapered feather key shaft	P = cylindrical feather key shaft
W = 65x3x20 DIN 5480	N = 55x3x17 DIN 5480		

## Diagrams

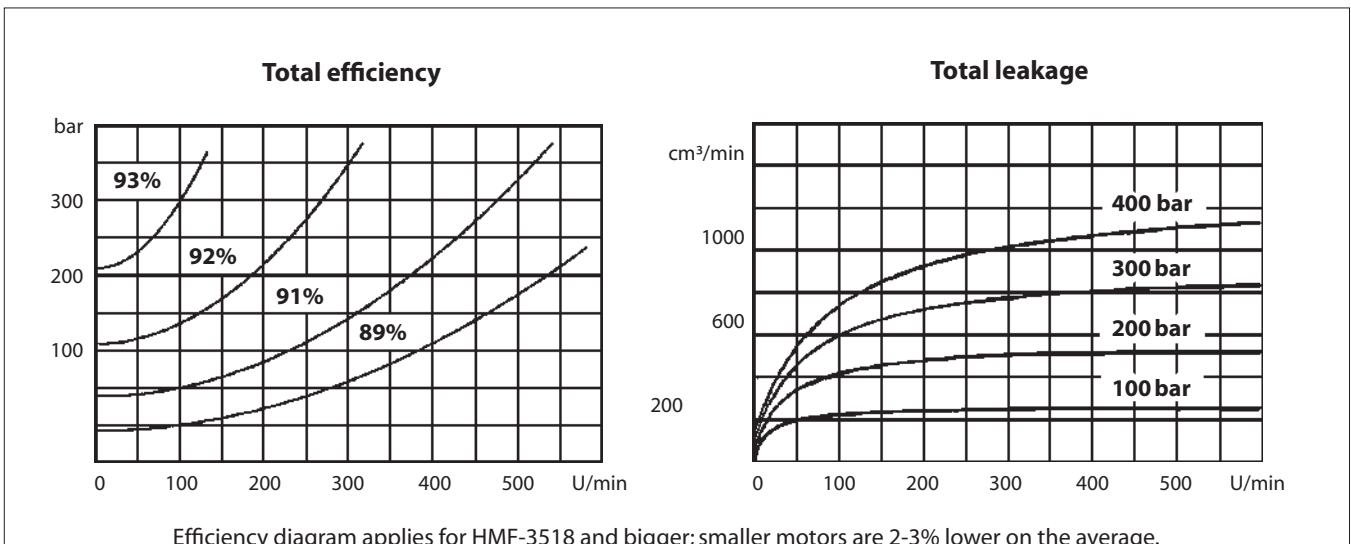

# Radial Piston Motor HMF-40..

All motors of the HMF-40.. series come with roller bearing, multiple spline shaft to BS 3550 and the J30 control. For notes on function, installation and start-up of the hydraulic motors please refer to page 3 to 5.

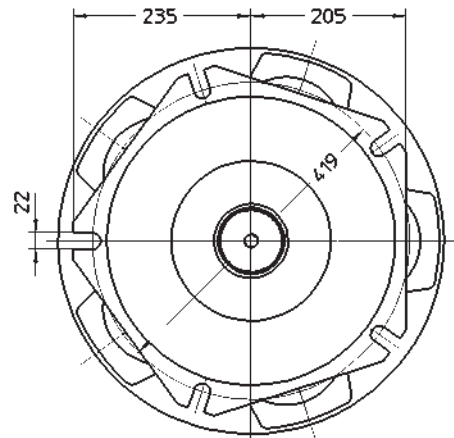
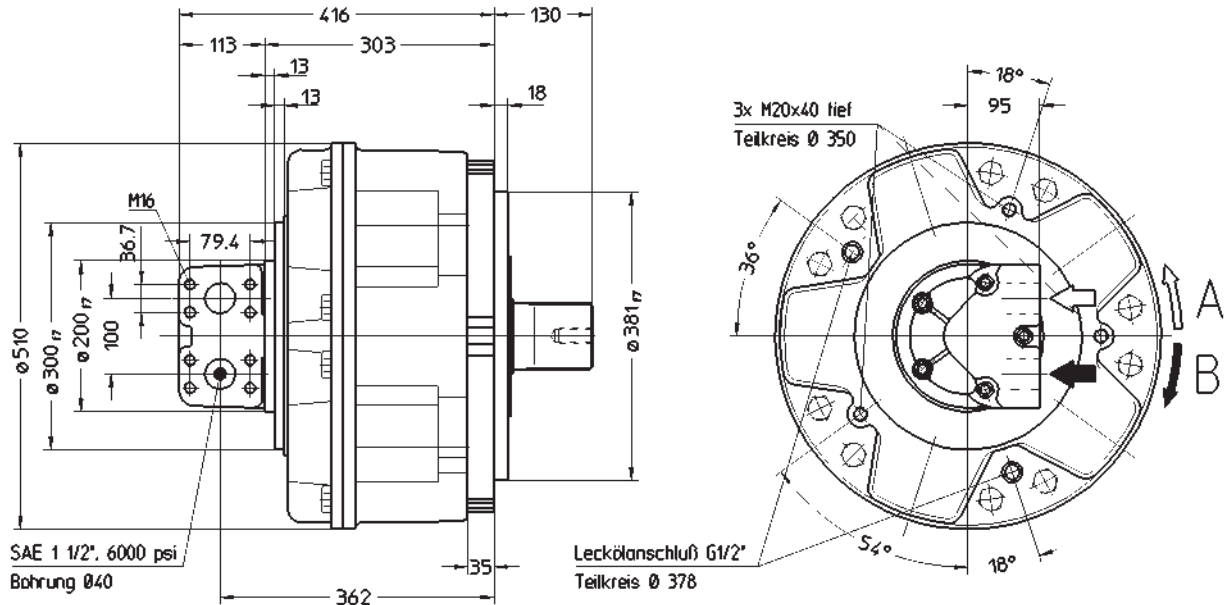

Weight approx. 240 kg  
 Mass moment of inertia 0,103 kgm<sup>2</sup>  
 Oil volume in motor case litres 25,0 litres

symbol DIN ISO 1219



## Model code

e.g. **HMF - 4033 - V A - J30/1 - TW**

**Series**

**nominal size**

**Output shafts**

- V** = multiple spline shaft BS 3550
- N** = multiple spline hollow shaft DIN 5480
- P** = feather key shaft

**Storage**

- C** = spherical roller bearing
- F** = conical roller bearing

**Tachogenerator**

- TW** = tachometer shaft Ø 6 mm
  - T** = tachogenerator
- models starting on page 36

**Control**

- J30** = pressure connection SAE 1½" 6000 psi
  - 1** = alignment to cylinder 1
- models starting on page 34

# Radial Piston Motor HMF-40..

Nominal size		4026	4033	4039	4047
Displacement	cm <sup>3</sup>	1690	2127	2513	3041
Specific theor. torque	Nm/bar	26,4	33,2	39,2	47,5
Peak pressure	bar	350	350	325	300
Continuous pressure	bar	250	250	250	250
Max. speed	U/min	350	300	250	200
Continuous speed	U/min	225	200	175	150
Max. power output	kW	150	150	150	150
Continuous power output	kW	90	90	90	90

## Output shafts

V = BS 3550 20T pitch 6 /12	N = 80x3x25, DIN 5480	P=cylindrical feather key shaft

## Diagrams

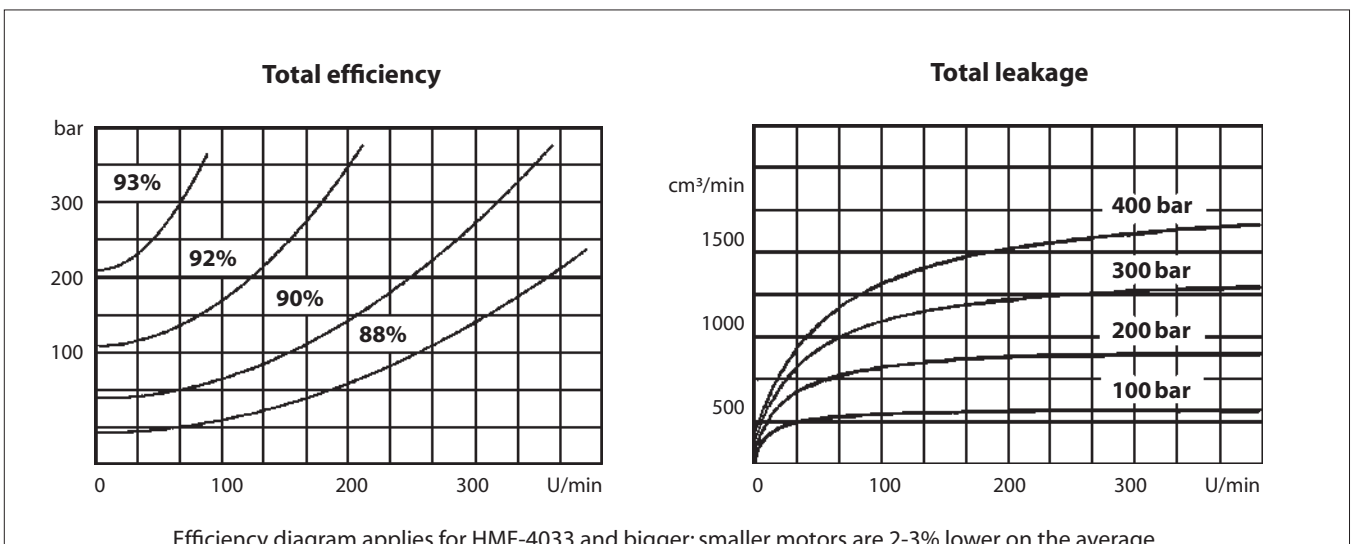

# Radial Piston Motor HMT-15..

All motors of the HMT-15.. series come with roller bearing, multiple spline shaft to DIN 5463 and the J21 control. For notes on function, installation and start-up of the hydraulic motors please refer to page 3 to 5.

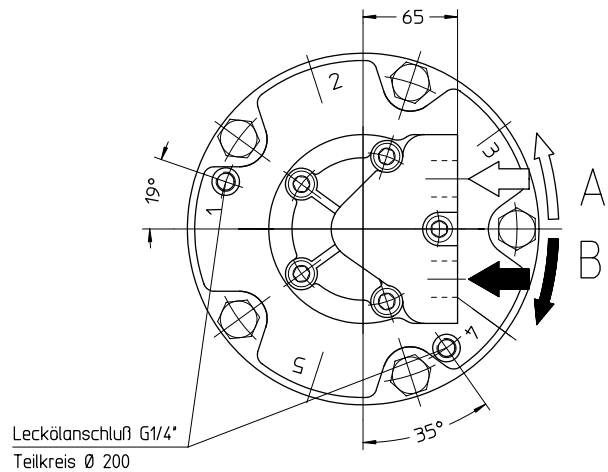
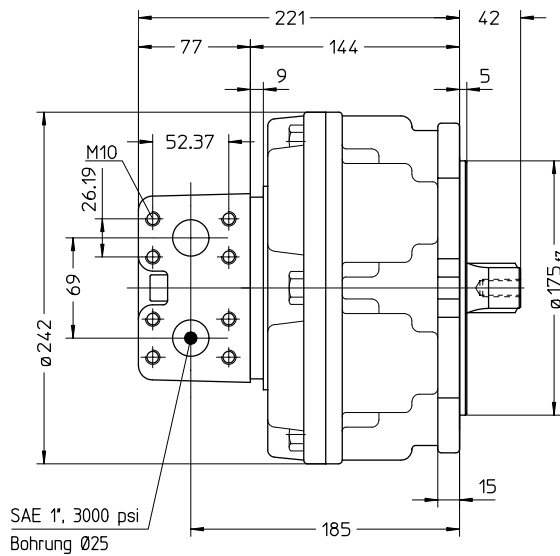

symbol DIN ISO 1219

Weight approx. 28 kg  
 Mass moment of inertia 0,0013 kgm<sup>2</sup>  
 Oil volume in motor case litres 1,0 litres

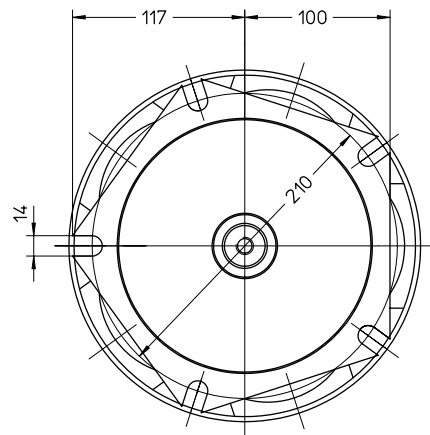

## Model code

e.g. **HMT - 1524 - V A - J21/1 - TW**

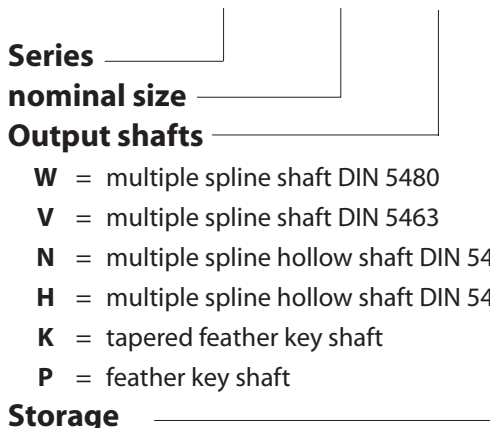

**Series**

**nominal size**

**Output shafts**

- W** = multiple spline shaft DIN 5480
- V** = multiple spline shaft DIN 5463
- N** = multiple spline hollow shaft DIN 5480
- H** = multiple spline hollow shaft DIN 5463
- K** = tapered feather key shaft
- P** = feather key shaft

**Storage**

- A** = roller bearing
- C** = spherical roller bearing

**Tachogenerator**

- TW** = tachometer shaft Ø 6 mm
- T** = tachogenerator  
models starting on page 36

**Control**

- J21** = pressure connection  
SAE 1" 3000 psi
- /1** = alignment to cylinder 1  
models starting on page 34

# Radial Piston Motor HMT-15..

Nominal size		1515	1524	1526	1531	1538
Displacement	cm <sup>3</sup> /Umdr	99	154	172	201	243
Specific theor. torque	Nm/bar	1,54	2,40	2,68	3,14	3,79
Peak pressure	bar	425	400	375	350	350
Continuous pressure	bar	250	250	250	250	250
Max. speed	U/min	2500	2200	1800	1500	1250
Continuous speed	U/min	1000	1000	900	800	700
Max. power output	kW	70	70	70	70	70
Continuous power output	kW	40	40	40	40	40

## Output shafts

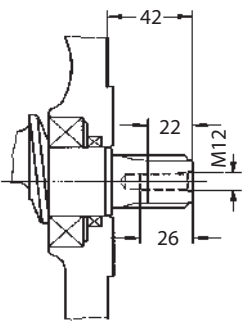
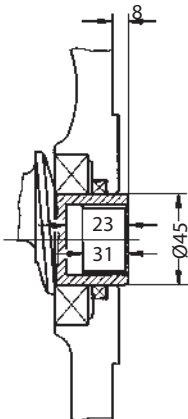
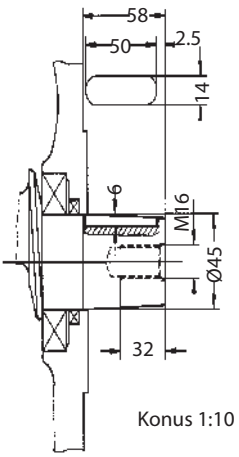
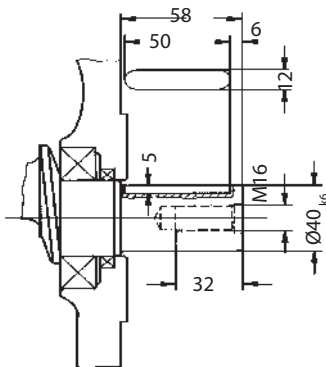
V = 6-28-34 DIN 5463	H = 6-28-34 DIN 5463	K = tapered feather key shaft	P = cylindrical feather key shaft
W = 35x2x16 DIN 5480	N = 35x2x16 DIN 5480		
			

## Diagrams

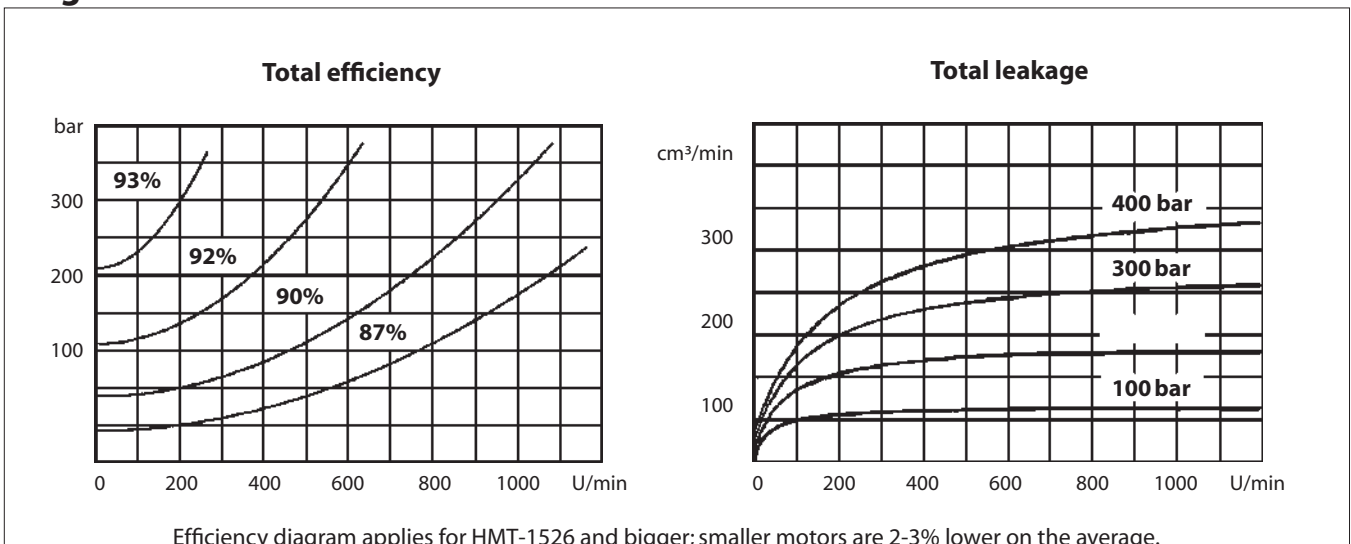

# Radial Piston Motor HMT-20..

All motors of the HMT-20.. series come with roller bearing, multiple spline shaft to DIN 5462 and the J21 control. For notes on function, installation and start-up of the hydraulic motors please refer to page 3 to 5.

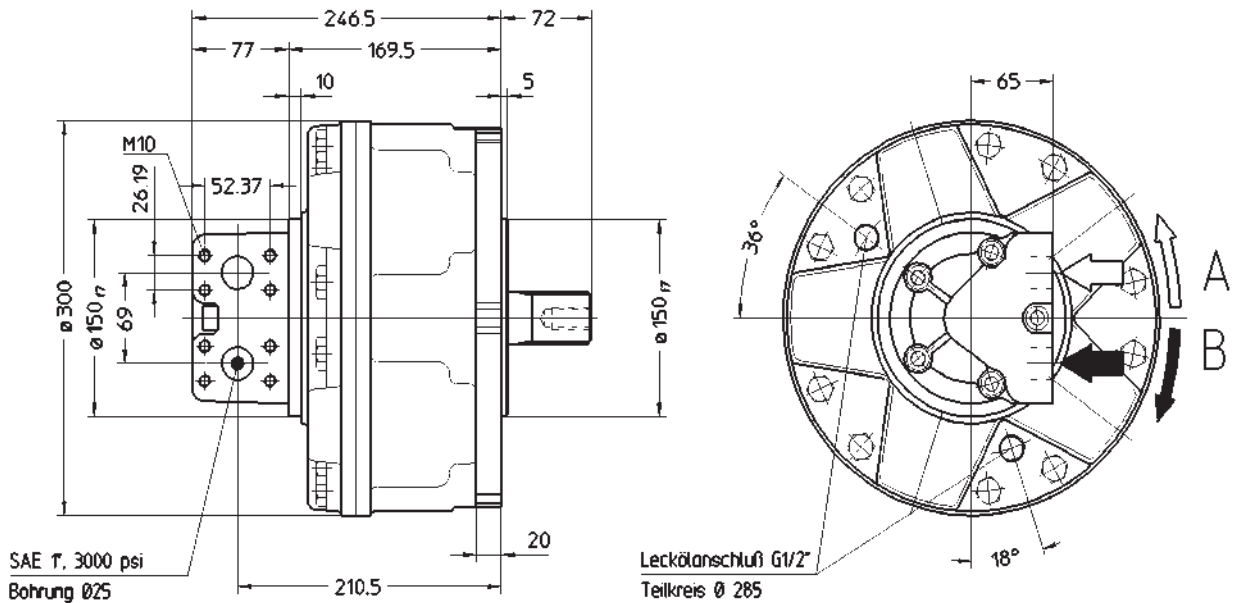

Weight approx. 52 kg  
 Mass moment of inertia 0,0046 kgm<sup>2</sup>  
 Oil volume in motor case litres 2,0 litres

symbol DIN ISO 1219

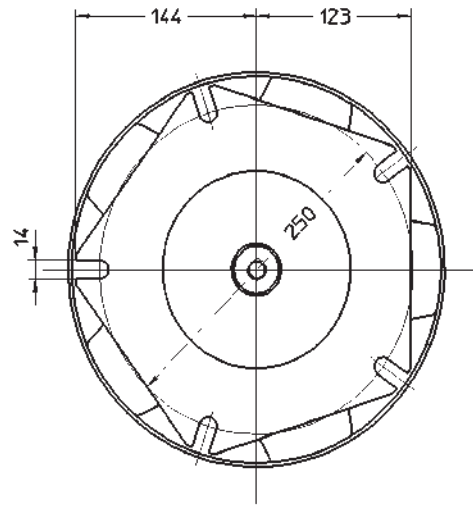

## Model code

e.g. **HMT - 2047 - V A - J21/1 - TW**

**Series**

**nominal size**

**Output shafts**

- W** = multiple spline shaft DIN 5480
- V** = multiple spline shaft DIN 5462
- N** = multiple spline hollow shaft DIN 5480
- H** = multiple spline hollow shaft DIN 5462
- K** = tapered feather key shaft
- P** = feather key shaft

**Storage**

- A** = roller bearing
- C** = spherical roller bearing

## Tachogenerator

**TW** = tachometer shaft Ø 6 mm

**T** = tachogenerator

models starting on page 36

## Control

**J21** = pressure connection

SAE 1" 3000 psi

**/1** = alignment to cylinder 1

models starting on page 34



# Radial Piston Motor HMT-20..

Nominal size		2030	2039	2047	2054	2066	2076
Displacement	cm <sup>3</sup> /Umdr	192	251	304	347	425	493
Specific theor. torque	Nm/bar	3,00	3,92	4,75	5,42	6,63	7,69
Peak pressure	bar	425	425	400	375	350	350
Continuous pressure	bar	250	250	250	250	250	250
Max. speed	U/min	1350	1250	1150	1100	900	850
Continuous speed	U/min	900	700	650	600	525	525
Max. power output	kW	80	80	80	80	80	80
Continuous power output	kW	45	45	45	45	45	45

## Output shafts

V = 8-36-40 DIN 5462	H = 8-36-40 DIN 5462	K = tapered feather key shaft	P = cylindrical feather key shaft
W = 40x3x12 DIN 5480	N = 40x3x12 DIN 5480		

## Diagrams

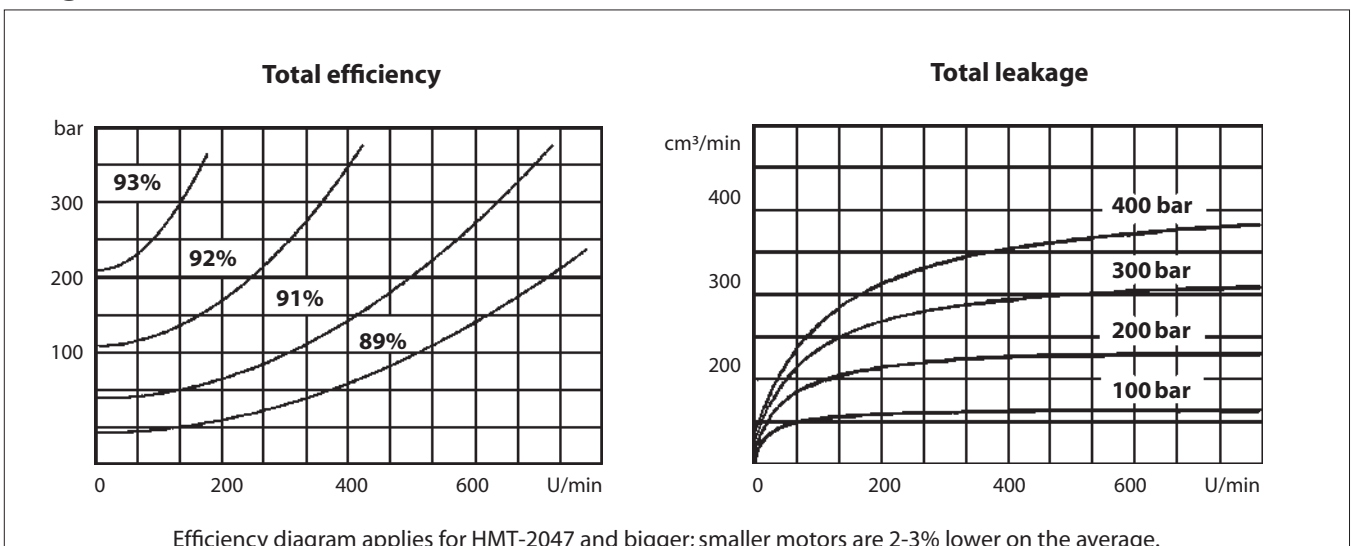

# Radial Piston Motor HMT-25..

All motors of the HMT-25.. series come with roller bearing, multiple spline shaft to DIN 5463 and the J30 control. For notes on function, installation and start-up of the hydraulic motors please refer to page 3 to 5.

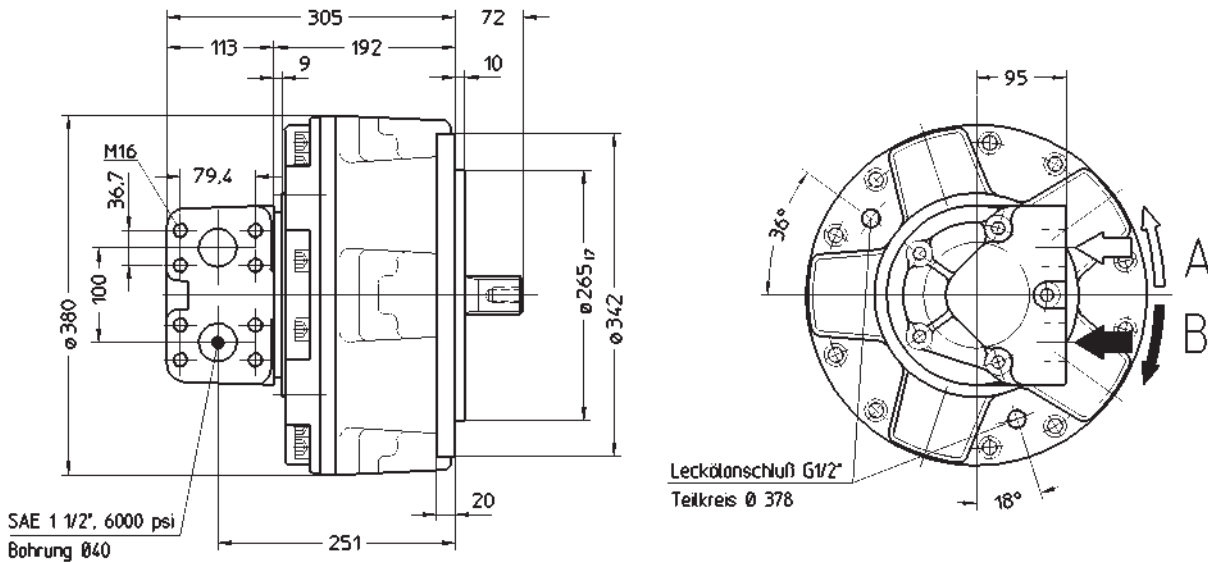

Weight approx. 87 kg  
 Mass moment of inertia 0,0098 kgm<sup>2</sup>  
 Oil volume in motor case litres 5,0 litres

symbol DIN ISO 1219

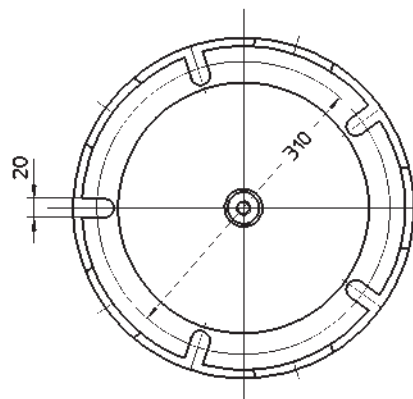

## Model code

e.g. **HMT - 2576 - V A - J30/1 - TW**

**Series**

**nominal size**

**Output shafts**

- W** = multiple spline shaft DIN 5480
- V** = multiple spline shaft DIN 5463
- N** = multiple spline hollow shaft DIN 5480
- H** = multiple spline hollow shaft DIN 5462
- K** = tapered feather key shaft
- P** = feather key shaft

**Storage**

- A** = roller bearing
- C** = spherical roller bearing

## Tachogenerator

- TW** = tachometer shaft Ø 6 mm
- T** = tachogenerator
- models starting on page 36

## Control

- J30** = pressure connection
- SAE 1 1/2" 6000 psi
- 1** = alignment to cylinder 1
- models starting on page 34

# Radial Piston Motor HMT-25..

Nominal size		2555	2566	2576	2593	2511	2512
Displacement	cm <sup>3</sup> /Umdr	352	426	486	595	690	792
Specific theor. torque	Nm/bar	5,49	6,64	7,58	9,28	10,8	12,4
Peak pressure	bar	425	425	425	400	350	350
Continuous pressure	bar	250	250	250	250	250	250
Max. speed	U/min	1000	850	800	800	750	750
Continuous speed	U/min	575	550	500	400	375	375
Max. power output	kW	100	100	100	100	100	100
Continuous power output	kW	60	60	60	60	60	60

## Output shafts

V = 8-46-54 W = 40x3x12	DIN 5463 DIN 5480	H = 8-36-40 N = 40x3x12	DIN 5462 DIN 5480	K = tapered feather key shaft	P = cylindrical feather key shaft	

## Diagrams

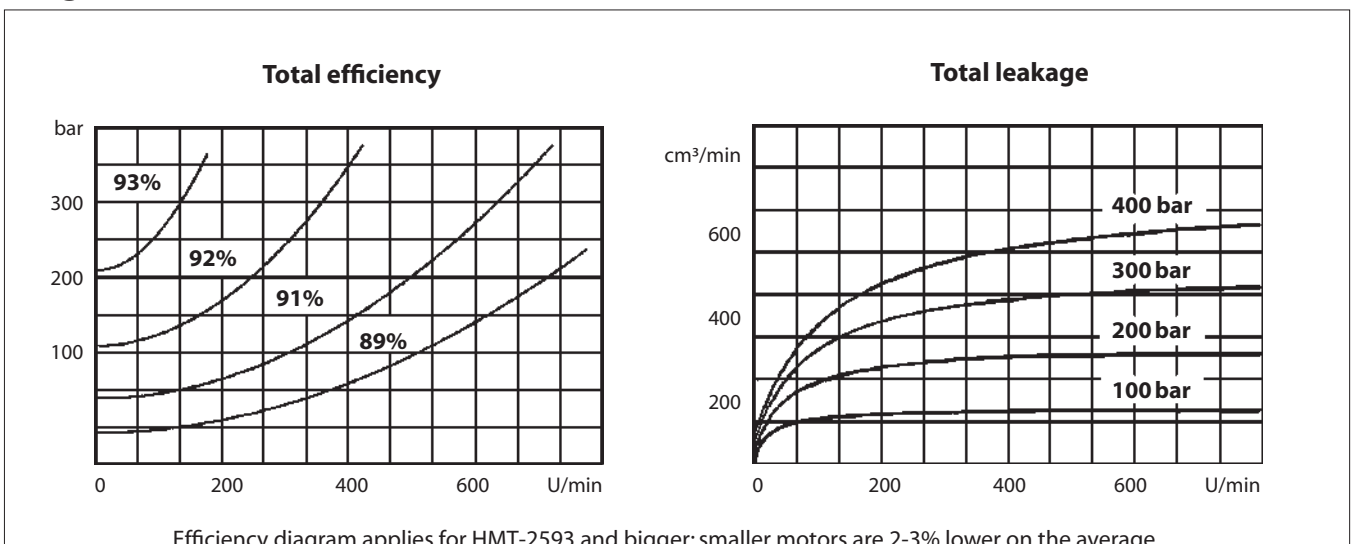

# Radial Piston Motor HMT-30..

All motors of the HMT-30.. series come with roller bearing, multiple spline shaft to DIN 5463 and the J30 control. For notes on function, installation and start-up of the hydraulic motors please refer to page 3 to 5.

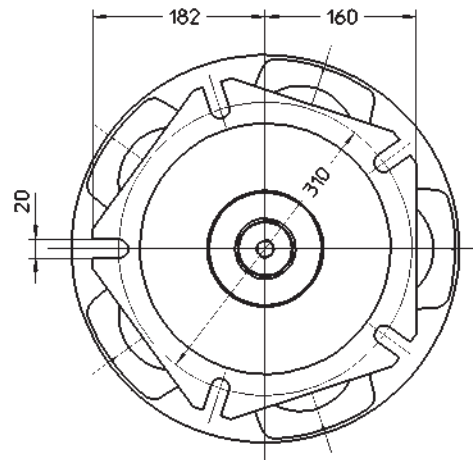
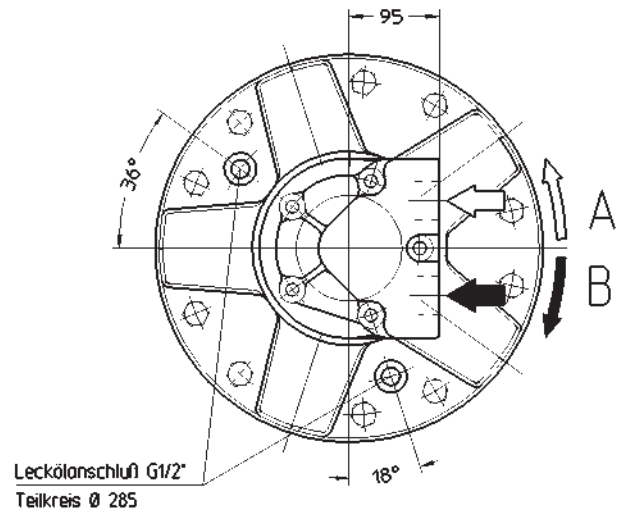
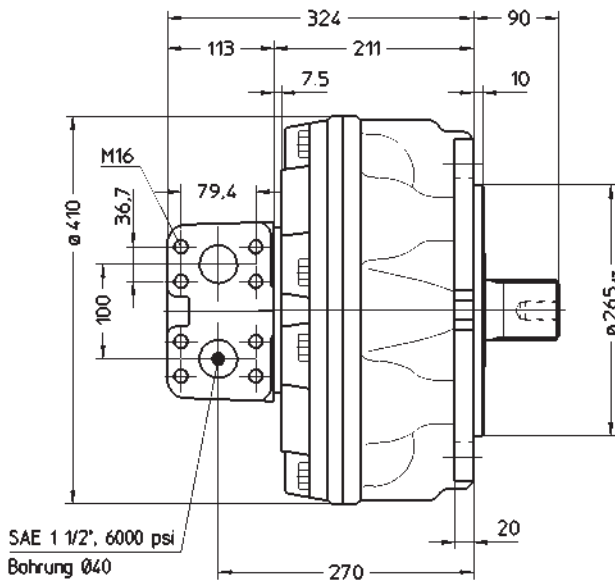

symbol DIN ISO 1219



Weight approx. 116 kg  
 Mass moment of inertia 0,0172 kgm<sup>2</sup>  
 Oil volume in motor case litres 7,0 litres

## Model code

e.g. **HMT - 3012 - V A - J30/1 - TW**

**Series**

**nominal size**

**Output shafts**

- W** = multiple spline shaft DIN 5480
- V** = multiple spline shaft DIN 5463
- N** = multiple spline hollow shaft DIN 5480
- H** = multiple spline hollow shaft DIN 5482
- K** = tapered feather key shaft
- P** = feather key shaft

**Storage**

- A** = roller bearing
- C** = spherical roller bearing

**Tachogenerator**

- TW** = tachometer shaft Ø 6 mm
  - T** = tachogenerator
- models starting on page 36

**Control**

- J30** = pressure connection
  - SAE 1 1/2" 6000 psi
  - /1** = alignment to cylinder 1
- models starting on page 34

# Radial Piston Motor HMT-30..

Nominal size		3078	3096	3012	3014	3016	3017
Displacement	cm <sup>3</sup> /Umdr	503	616	793	904	1022	1116
Specific theor. torque	Nm/bar	7,85	9,61	12,4	14,1	16	17,4
Peak pressure	bar	425	400	400	375	350	350
Continuous pressure	bar	250	250	250	250	250	250
Max. speed	U/min	780	750	730	700	700	650
Continuous speed	U/min	600	575	550	500	450	400
Max. power output	kW	150	150	150	150	150	150
Continuous power output	kW	80	80	80	80	80	80

## Output shafts

V = 8-56-65 DIN 5463	H = A 55x50 DIN 5482	K = tapered feather key shaft	P = cylindrical feather key shaft
W = 65x3x20 DIN 5480	N = 55x3x17 DIN 5480		

## Diagrams

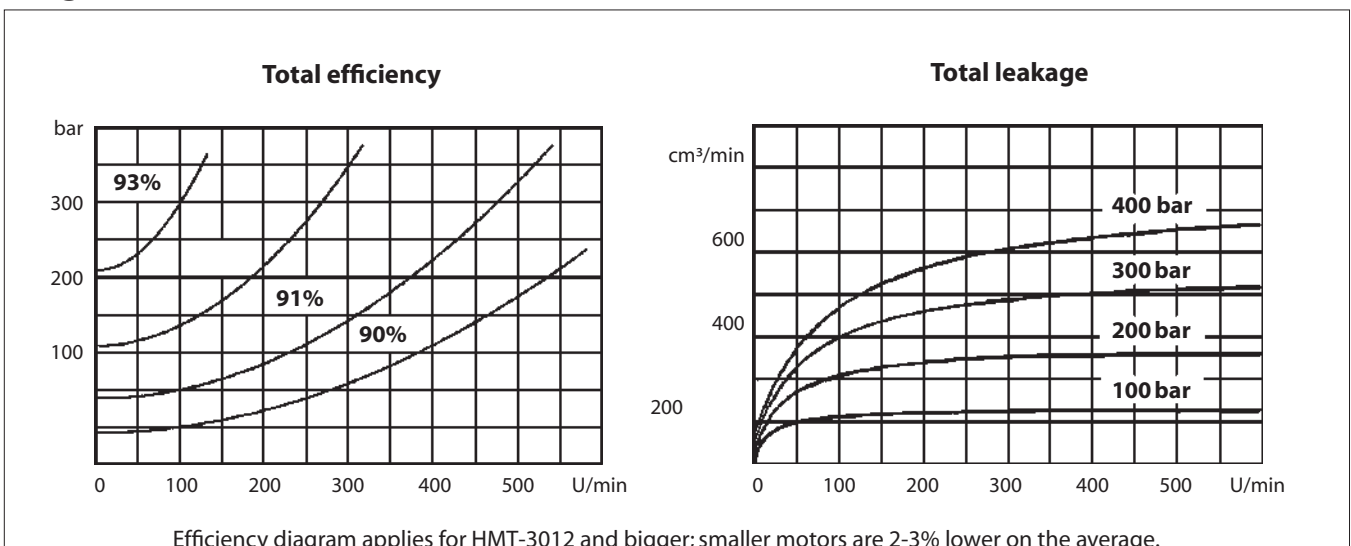

# Radial Piston Motor HMT-35..

All motors of the HMT-35.. series come with roller bearing, multiple spline shaft to DIN 5463 and the J30 control. For notes on function, installation and start-up of the hydraulic motors please refer to page 3 to 5.

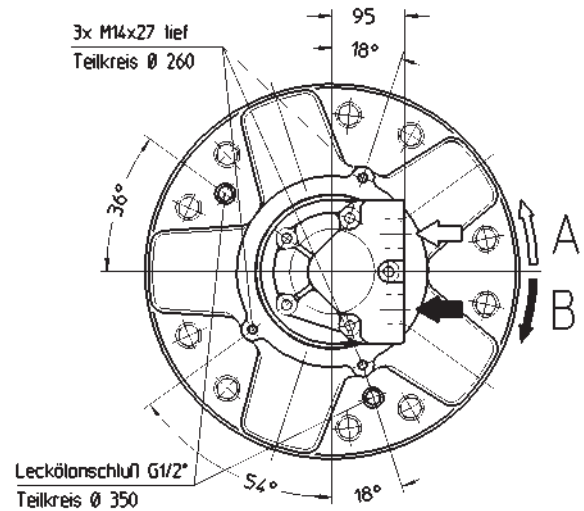
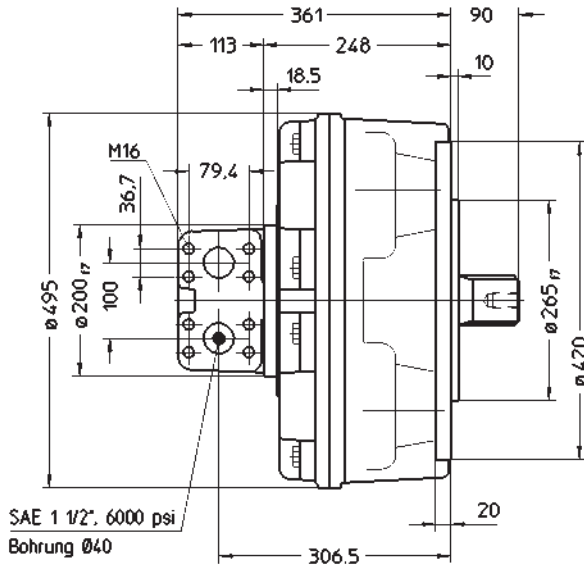

Weight approx. 182 kg  
 Mass moment of inertia 0,0277 kgm<sup>2</sup>  
 Oil volume in motor case litres 10,0 litres

symbol DIN ISO 1219

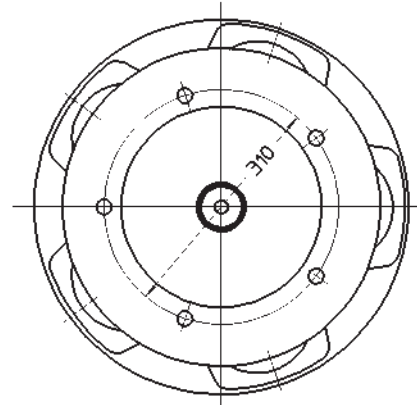

## Model code

e.g. **HMT - 3518 - V A - J30/1 - TW**

**Series**

**nominal size**

**Output shafts**

- W** = multiple spline shaft DIN 5480
- V** = multiple spline shaft DIN 5463
- N** = multiple spline hollow shaft DIN 5480
- H** = multiple spline hollow shaft DIN 5482
- K** = tapered feather key shaft
- P** = feather key shaft

**Storage**

- A** = roller bearing
- C** = spherical roller bearing

**Tachogenerator**

**TW** = tachometer shaft Ø 6 mm

**T** = tachogenerator

models starting on page 36

**Control**

**J30** = pressure connection G1"

**/1** = alignment to cylinder 1

models starting on page 34

# Radial Piston Motor HMT-35..

Nominal size		3510	3512	3516	3518	3521	3523	3525	3528
Displacement	cm <sup>3</sup> /Umdr	659	807	1039	1185	1340	1462	1634	1816
Specific theor. torque	Nm/bar	10,3	12,6	16,2	18,5	20,9	22,8	25,3	28,3
Peak pressure	bar	425	425	425	400	400	375	375	350
Continuous pressure	bar	250	250	250	250	250	250	250	250
Max. speed	U/min	730	700	680	630	600	600	600	550
Continuous speed	U/min	500	500	475	475	450	450	400	375
Max. power output	kW	200	200	200	200	200	200	200	200
Continuous power output	kW	115	115	115	115	115	115	115	115

## Output shafts

V = 8-56-65 DIN 5463	H = A 55x50 DIN 5482	K = tapered feather key shaft	P = cylindrical feather key shaft
W = 65x3x20 DIN 5480	N = 55x3x17 DIN 5480		

## Diagrams

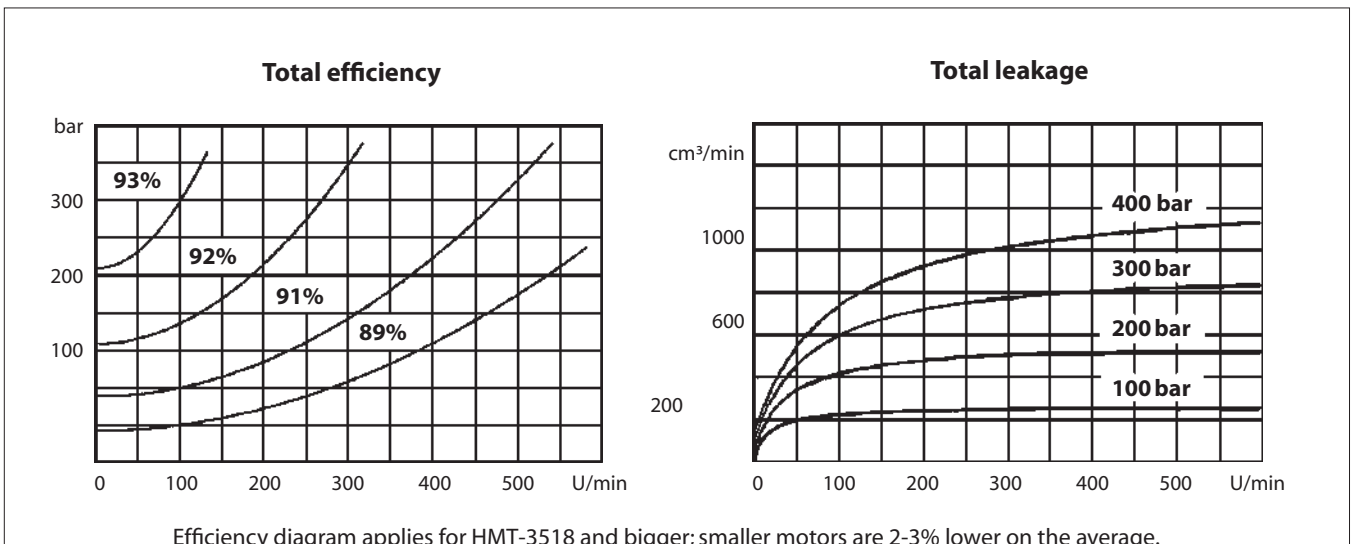

# Radial Piston Motor HMT-40..

All motors of the HMT-40.. series come with roller bearing, multiple spline shaft to BS 3550 and the J40 control. For notes on function, installation and start-up of the hydraulic motors please refer to page 3 to 5.

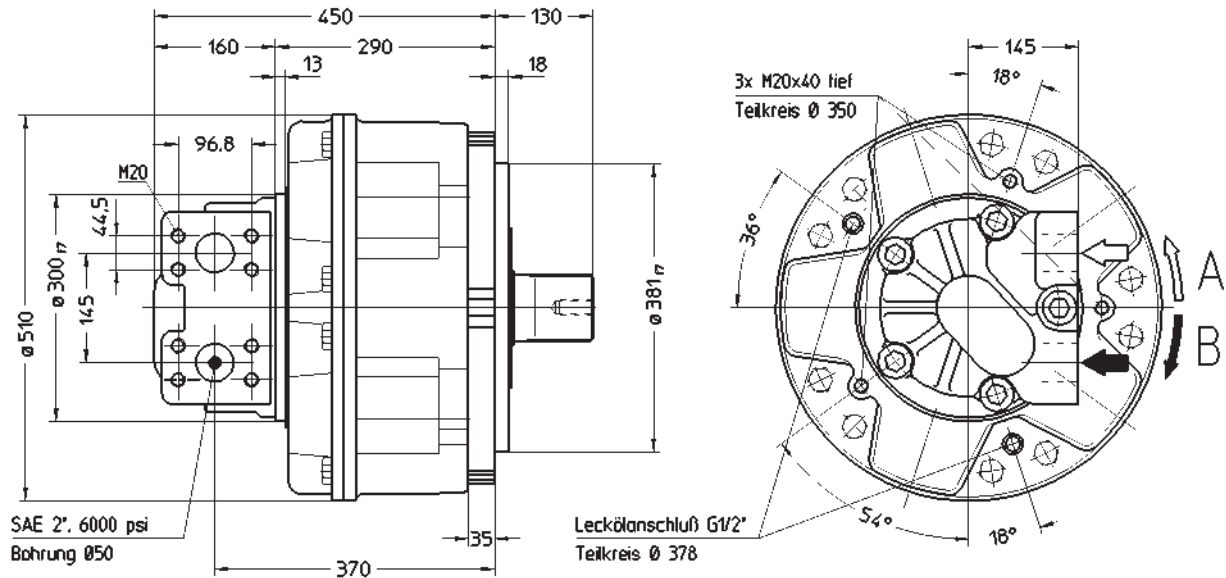

Weight approx. 291 kg  
 Mass moment of inertia 0,103 kgm<sup>2</sup>  
 Oil volume in motor case litres 25,0 litres

symbol DIN ISO 1219

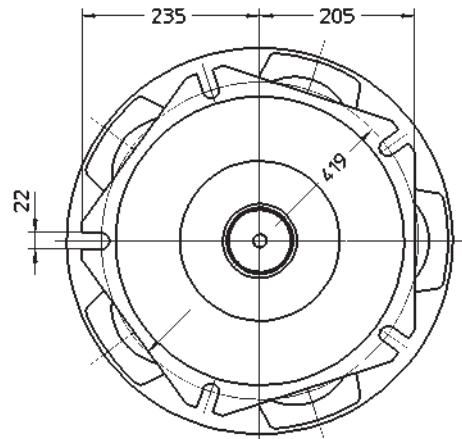

## Model code

e.g. **HMT - 4033 - V A - J40/1 - TW**

**Series** \_\_\_\_\_  
**nominal size** \_\_\_\_\_  
**Output shafts** \_\_\_\_\_

**V** = multiple spline shaft BS 3550  
**N** = multiple spline hollow shaft DIN 5480  
**P** = feather key shaft

**Tachogenerator**  
**TW** = tachometer shaft Ø 6 mm  
**T** = tachogenerator  
 models starting on page 36

**Storage** \_\_\_\_\_  
**C** = spherical roller bearing

**Control**  
**J40** = pressure connection  
 SAE 2" 6000 psi  
**/1** = alignment to cylinder 1  
 models starting on page 34



# Radial Piston Motor HMT-40..

Nominal size		4026	4033	4039
Displacement	cm <sup>3</sup> /Umdr	1690	2127	2513
Specific theor. torque	Nm/bar	26,4	33,2	39,2
Peak pressure	bar	425	400	350
Continuous pressure	bar	250	250	250
Max. speed	U/min	600	575	500
Continuous speed	U/min	400	400	300
Max. power output	kW	300	300	300
Continuous power output	kW	160	160	160

## Output shafts

V = BS 3550 20T pitch 6 /12	N = 80x3x25, DIN 5480	P = cylindrical feather key shaft

## Diagrams

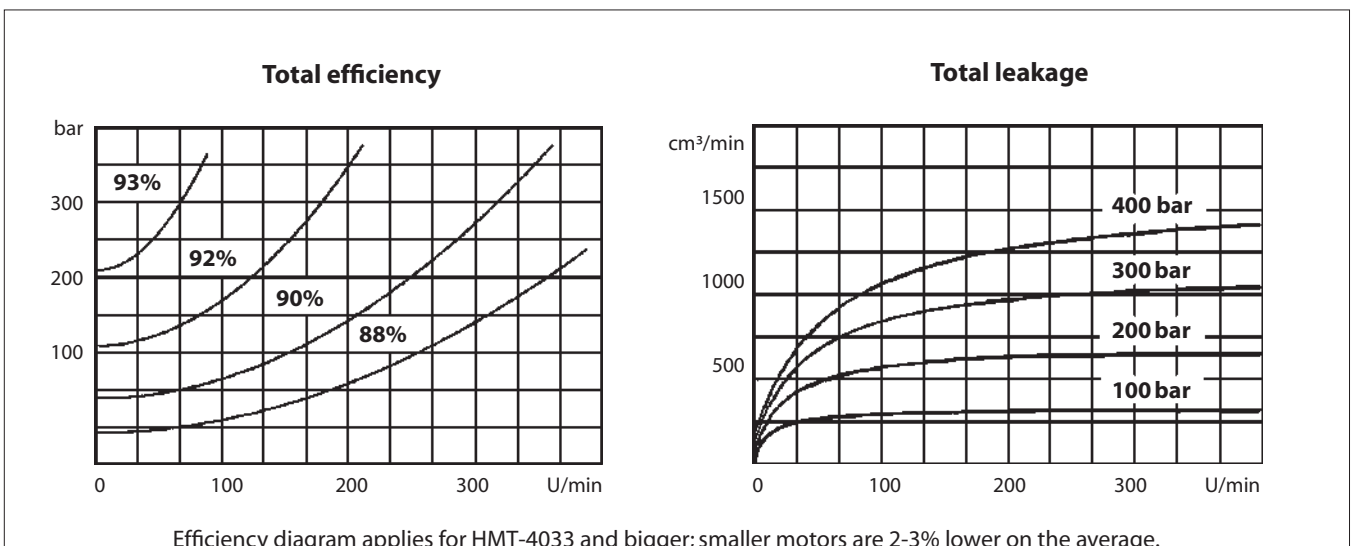

# Distributors

## Distributor J20 G1" connections

standard control for all hydraulic motors from the HMF series

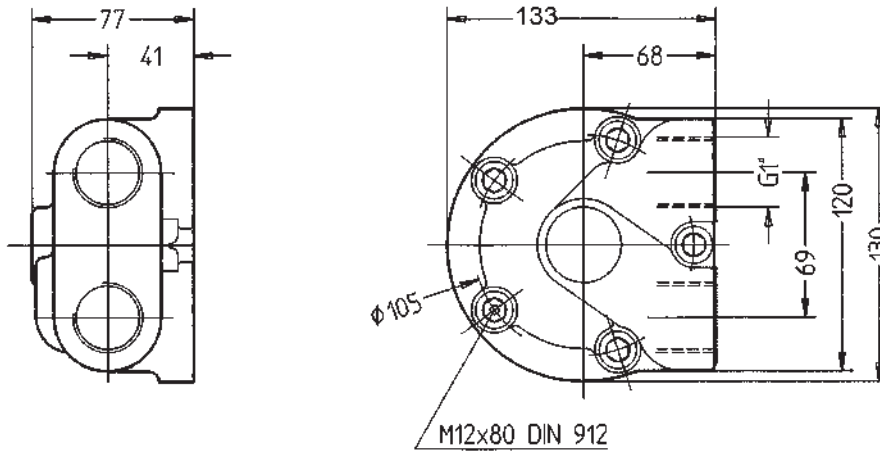

## Distributor J21 connections SAE 1", 3000 psi (210 bar)

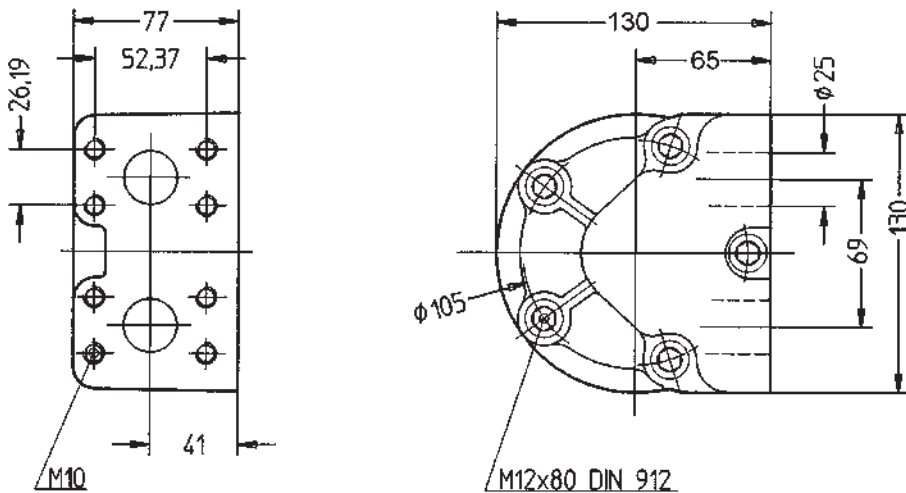

# Distributors

**Distributor J30** connections SAE 1½", 6000 psi (420 bar)  
for all hydraulic motors from the HMF-40.. and HMC-45.. series standard.  
for all hydraulic motors from the HMF-35 series alternatively.

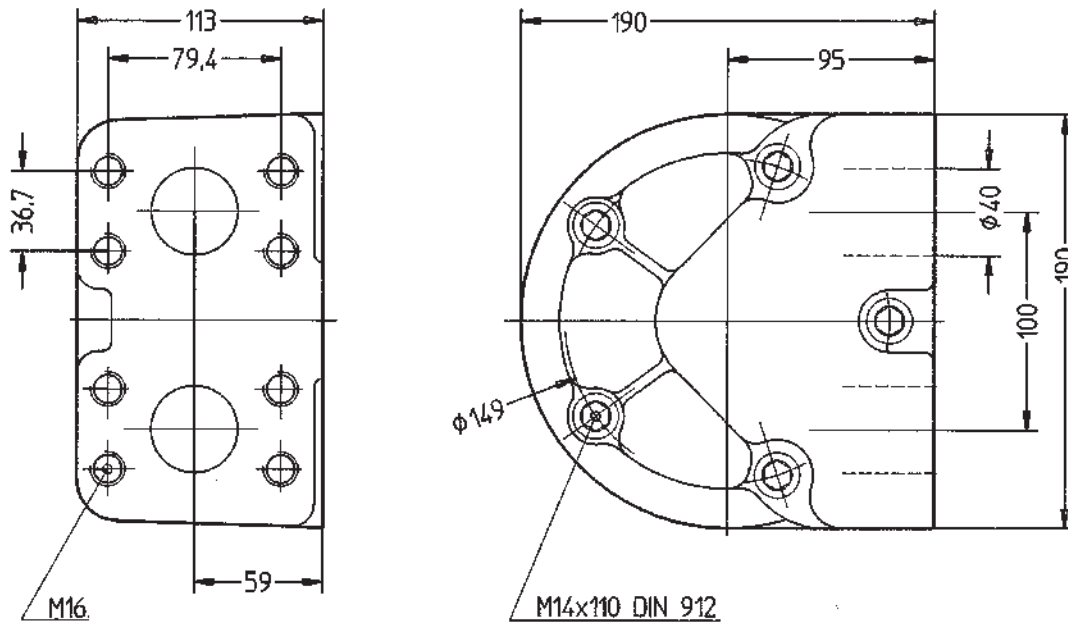

**Distributor J40** connections SAE 2", 6000 psi (420 bar)  
for all hydraulic motors from the HMT-40.. serie standard.

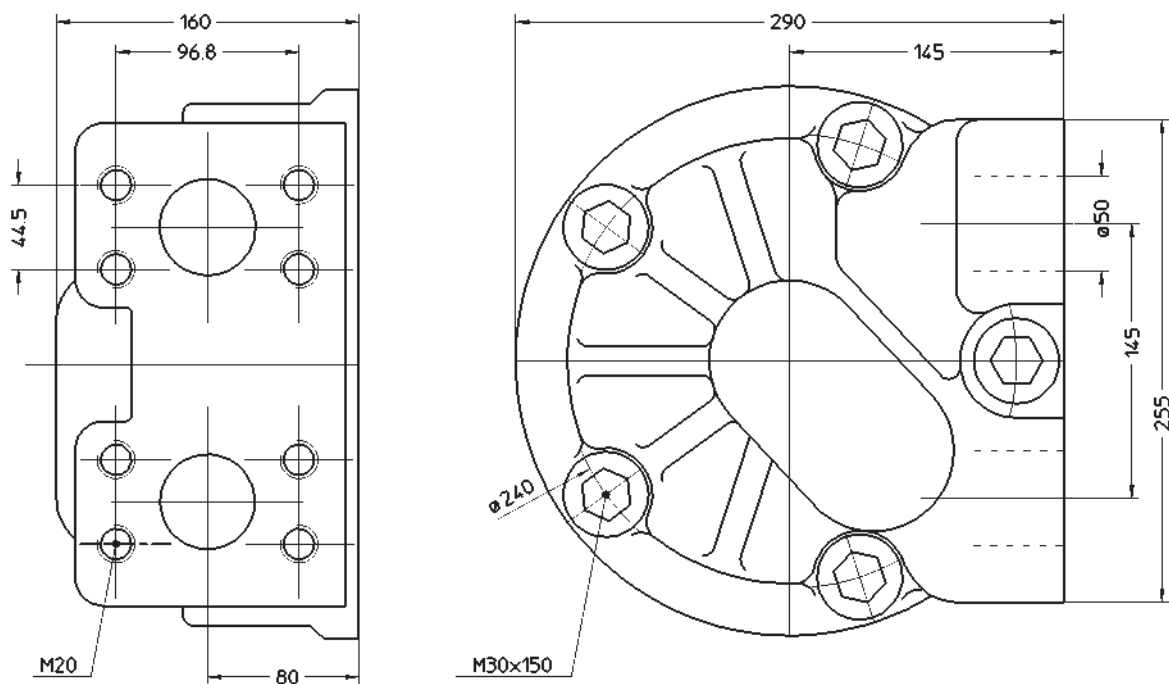

# Tachometer

## Tachometer shaft TW with J20 control

The 6 mm tachometer shaft is available for all controls

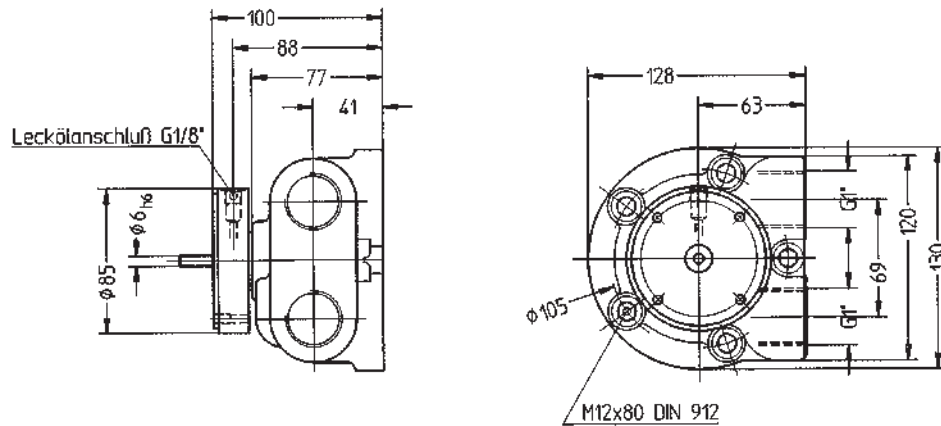

## Tachometer shaft TW with J21 control

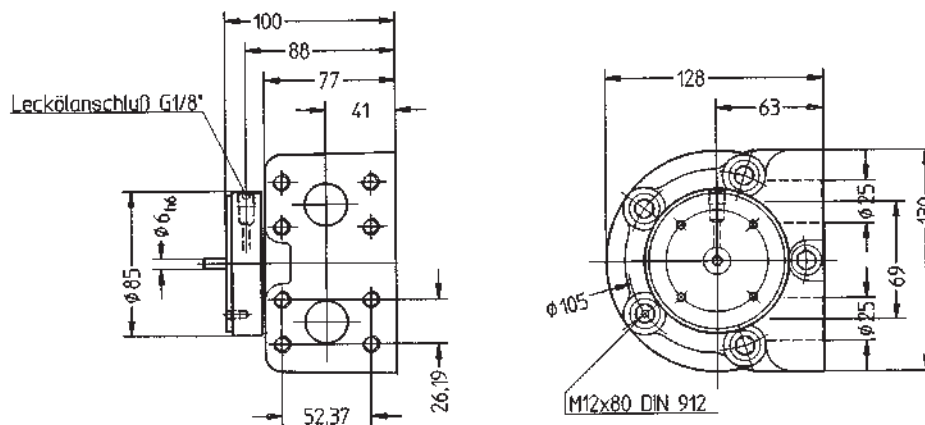

## Contact-free tachometer DMS with 24 pulses per revolution

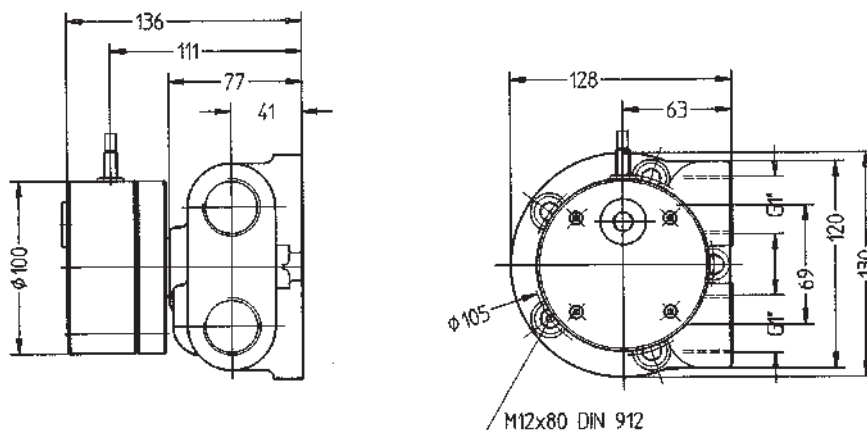

# Tachometer

## Tachometer TD41 or TD42

TD41 rectified three-phase current 50V/1000 rpm, TD42 rectified three-phase current 100V/1000 rpm

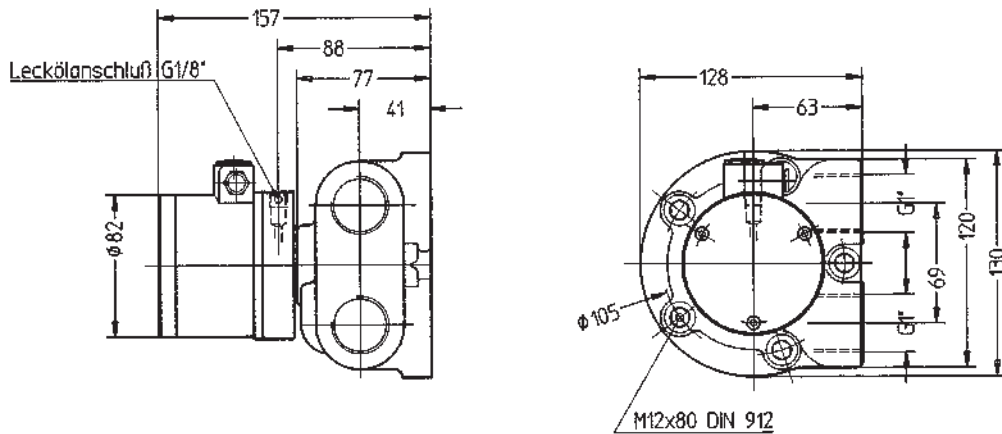

## DC tachometer KTD3

Nominal voltages from 10V/1000 rpm to 60V/1000 rpm are available

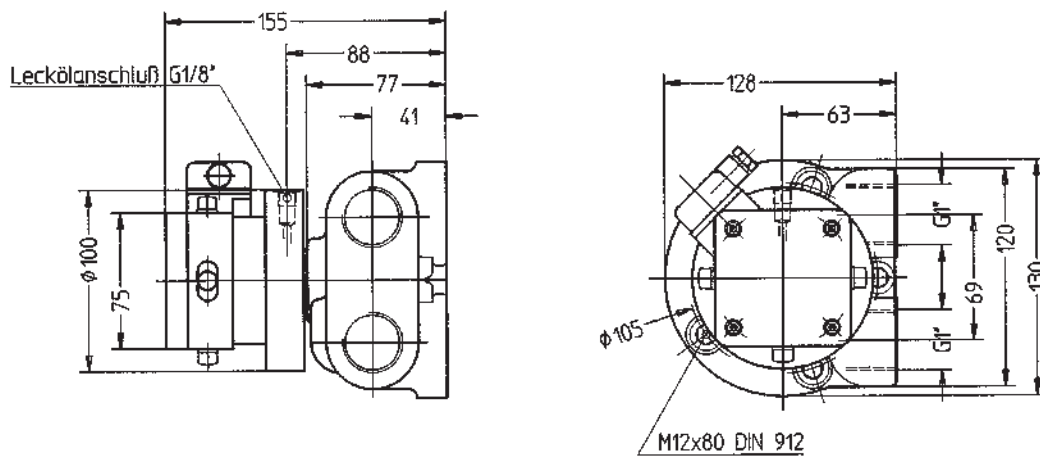

# Components for hydraulics and process technology

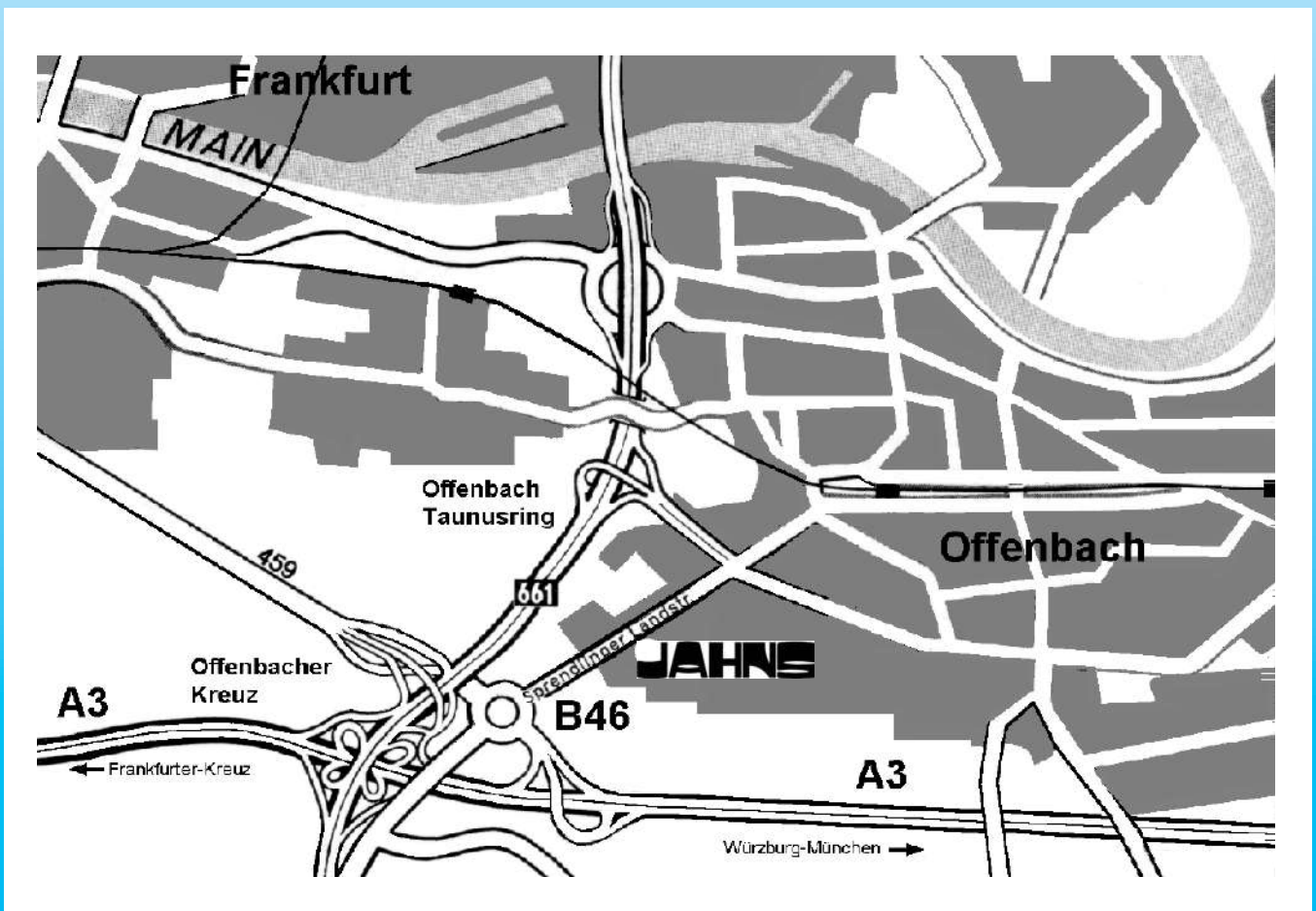

## **Jahns-Regulatoren GmbH**

Postfach 10 09 52  
D 63009 Offenbach  
Phone +49/(0)69/84 84 77-0

Adress:  
Sprenglinger Landstraße 150  
D 63069 Offenbach  
Fax +49/(0)69/84 84 77 25

<http://www.jahns-hydraulik.de>  
[info@jahns-hydraulik.de](mailto:info@jahns-hydraulik.de)