

# JARVIS

## PFI-1

# PICKING FINGER INSTALLER

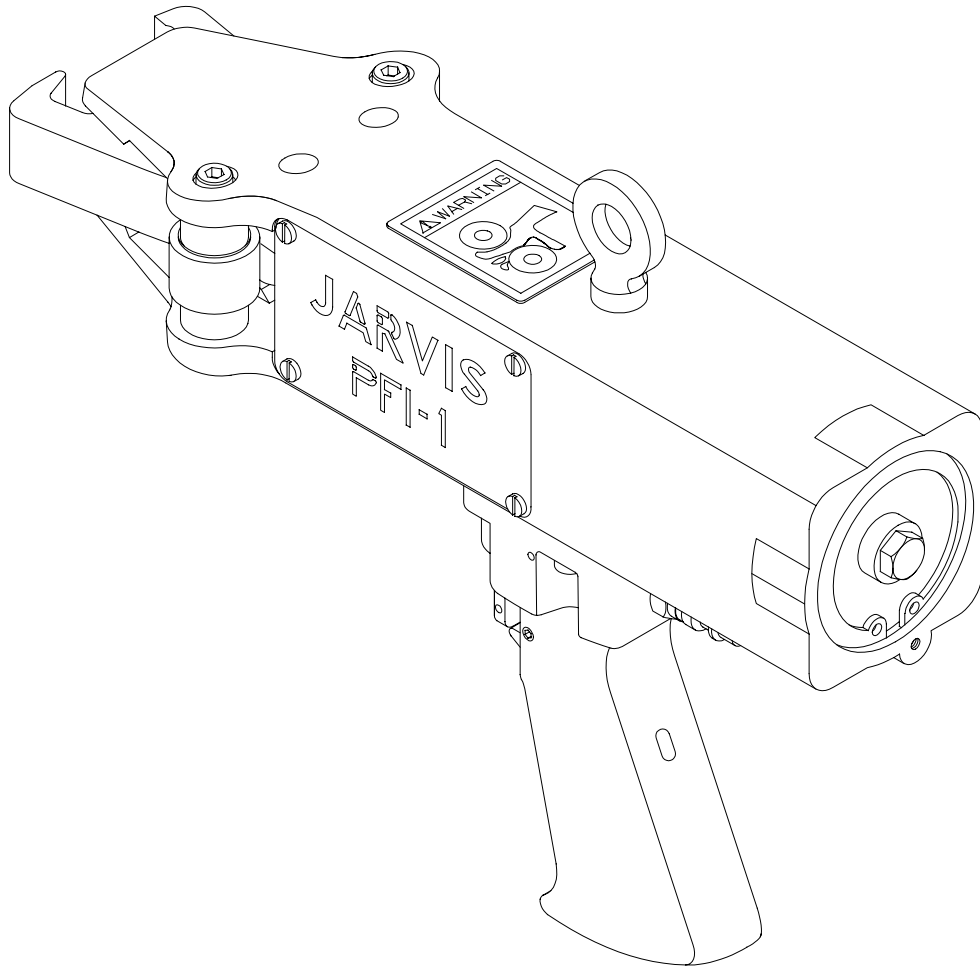

EQUIPMENT SELECTION .....	Ordering No.
---------------------------	--------------

PFI-1 .....	4311002
Balancer .....	1350147

TABLE OF CONTENTS .....	Page
-------------------------	------

- |  |   |
|--|---|
| • Safety Messages to Employer and Safety Director .....                | 2 |
| • Safety Messages to Operators Maintenance and Cleanup Personnel ..... | 3 |
| • Parts Diagram and List .....   | 4 |
| • Specifications .....   | 5 |
| • Installation Instructions .....                                      | 5 |
| • Operation Instructions .....   | 5 |
| • Maintenance Instructions .....                                       | 6 |

# JARVIS®

6223015..

## PRODUCTS CORPORATION

33 ANDERSON ROAD, MIDDLETOWN, CONNECTICUT 06457-4926

UNITED STATES OF AMERICA E-Mail [sales@jarvisproducts.com](mailto:sales@jarvisproducts.com)

TEL. 860-347-7271 FAX. 860-347-6978 [WWW.jarvisproducts.com](http://WWW.jarvisproducts.com)



**SAFETY MESSAGES TO EMPLOYER AND SAFETY DIRECTOR**  
*AVOID INJURY*

1. **Ensure** that all employees who use this tool are trained in the proper use of this tool and are aware of the dangers that may arise if they do not follow procedures outlined in this brochure.
2. **Enclosed** are four (4) copies of “NOTICE TO OPERATORS, MAINTENANCE AND CLEANUP PERSONNEL.” Post one copy on the employees’ bulletin board; give one copy to the operator(s); give one copy to the maintenance foreman; and give one copy to the sub-contract cleanup / internal cleanup foreman. *Additional copies will be provided upon request.*
3. The tool is designed and intended to be powerful. This fact should be obvious to your employees, but you must emphasize it to them.
4. **Ensure** that proper procedures are established (in accordance with OSHA’s lockout/tagout procedures 29 CFR 1910.147) to prevent accidental startup or release of stored energy.
5. **Remove** and **repair** any tool that malfunctions. **All** personnel must be instructed to remove any malfunctioning equipment.
6. **Never** make modifications or alterations to the tool. *Replace any missing or illegible labels.*
7. **Follow** our installation and maintenance instructions for proper installation and care of the tool.
8. **Avoid** injury. Do not permit the tool to be misused.
9. **If you resell or distribute** a Jarvis product, you must provide the purchaser with the appropriate safety sheets and tool brochure. *Additional copies of safety sheets and tool brochures will be provided upon request.*



**SAFETY MESSAGES TO OPERATORS, MAINTENANCE AND CLEANUP  
PERSONNEL**

***REMOVE ANY MALFUNCTIONING TOOL FROM SERVICE  
REPORT ANY PROBLEMS TO YOUR SUPERVISOR***

1. **Disconnect** the air hose in accordance with OSHA's lockout/tagout procedures (29 CFR 1910.147) before performing any repair or maintenance.
2. **Disconnect** the air hose - or have the air hose disconnected - in accordance with OSHA's lockout/tagout procedures (29 CFR 1910.147) before performing any cleanup.
3. **Disconnect** the air hose when the tool is not being used.
4. **Never** put fingers, hands or other parts of the body in the path of the moving claws while tool is connected to the air supply.
5. **Test** the tool prior to use or daily. **Depress** trigger and the claws should move into the frame. **Release** the trigger and the claws should move out of the frame. If the tool malfunctions, remove it from service and report or repair it immediately.
6. **Never** depress the trigger unless you want to use the tool.
7. **Never** make modifications or alterations to the tool. *Replace any missing or illegible labels.*

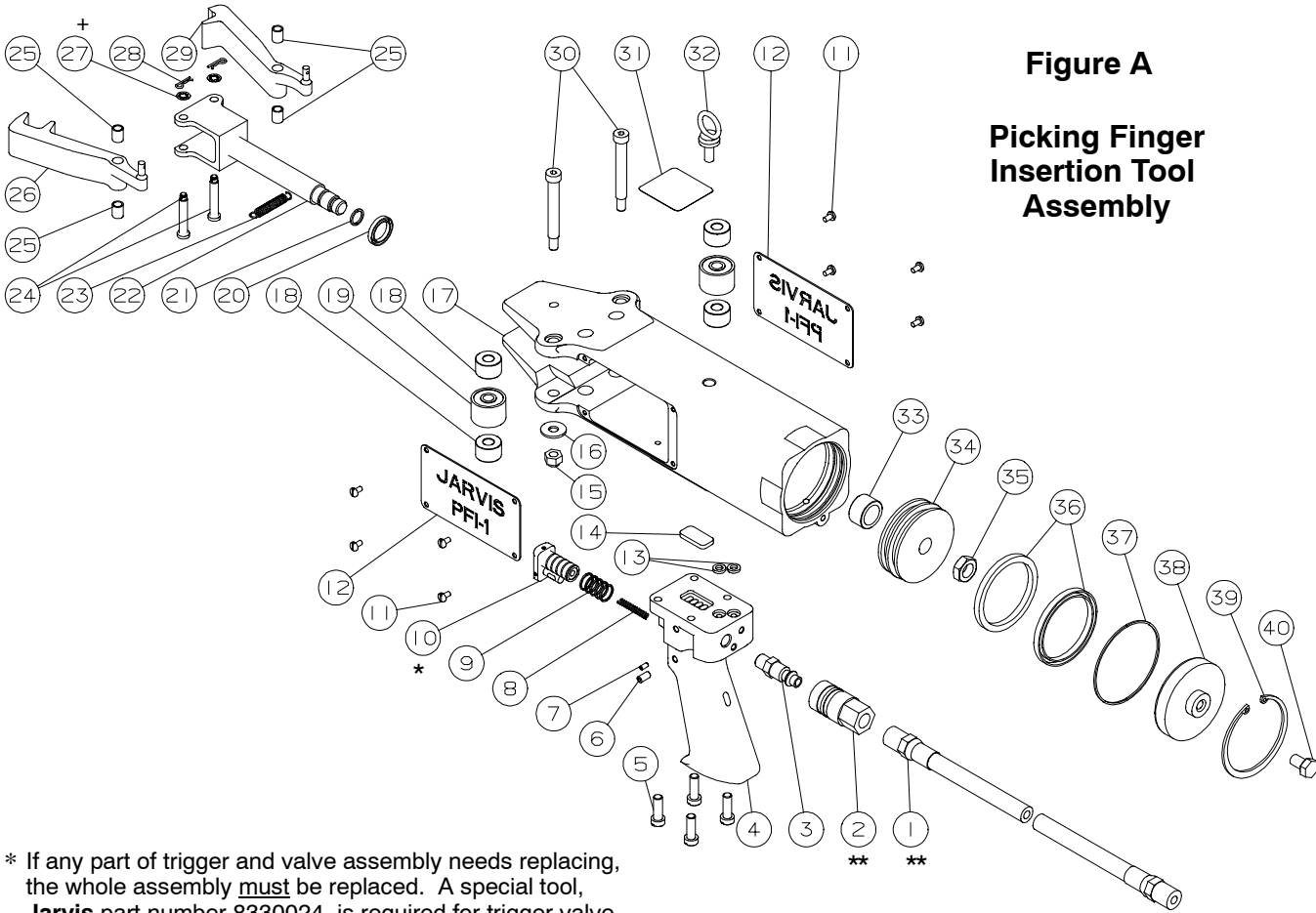

**Figure A**

**Picking Finger  
Insertion Tool  
Assembly**

\* If any part of trigger and valve assembly needs replacing, the whole assembly must be replaced. A special tool, **Jarvis** part number 8330024, is required for trigger valve sleeve removal and installation.

ITEM	PART NO.	PART NAME	QTY
1	1323011**	Hose Assy (incl. item 2)	1
2	1324078**	Quick Connect Socket	1
3	1324117	Quick Connect Plug	1
4	1347020	Handle	1
5	1301135	Fillister Head Screw	4
6	1301134	Set Screw	1
7	1301133	Set Screw	1
8	1336029	Compression Spring	1
9	1035336	O-ring (package of 5)	1
10	3345001*	Trigger and Valve Assembly (includes item 9)	1
11	1301138	Pan Head Screw	8
12	1304121	Guard Plate	2
13	1343061	O-ring	2
14	1343071	Rectangular Gasket	1
15	1302027	Hex Lock Nut	2
16	1303104	Plain Washer	2
17	1330059	Frame and Cyl. Housing.	1
18	1316068	Spacer	4
19	1311035	Cam Roller	2
20	1343058	U-cup Seal	1
21	1343060	O-ring	1
22	1312060	Piston Rod and Yoke	1
23	1336028	Extension Spring	1

+ Not used in current tools

\*\* Available as spare part only, not included with tool.

ITEM	PART NO.	PART NAME	QTY
24	1327128	Pivot Pin	2
25	1338030	Bushing	4
26	1349002	Double Claw (left side)	1
27	1317028+	Retaining Ring	2
28	1327147	Cotter Pin	2
29	1349003	Single Claw (right side)	1
30	1301137	Socket Head Screw	2
31	1017325	Danger Label	1
32	1301116	Eye Bolt	1
33	1338029	Bushing	1
34	1305044	Piston	1
35	1302033	Hex Jam Nut	1
36	1343057	U-cup Seal	2
37	1343059	O-ring	1
38	1322009	End Cap	1
39	1317027	Retaining Ring	1
40	1301136	Hex Screw	1
	8330024*	Special Tool (not shown)	1

## SPECIFICATIONS

### Model PFI-1

Operating Pressure	90 psi	6.2 bar
Air Consumption		
Per Cycle at 90 psi		0.091 ft <sup>3</sup>
Per Cycle at 6.2 bar		2.58 L
Overall Length	12.3 in	312 mm
Overall Width	4.0 in	102 mm
Opening Dimension (expanded)		
width x height	1 x 1 in	25.4 x 25.4 mm
depth	4.75 in	120.7 mm
Weight	5.9 lbs	2.7 kg

## INSTALLATION INSTRUCTIONS

- 1 Install the PFI-1 above the work area from a balancer, if applicable. **Jarvis** part number 1350147 is available.
  - 1.1 The PFI-1 should have sufficient travel to allow the operator to reach the entire work area.
- 2 Make the necessary air connection.
  - 2.1 The minimum required compressed air supply is 0.091 ft<sup>3</sup> / cycle at 90 psi (2.58 L / cycle at 6.2 bar).
  - 2.2 An air filter/regulator/lubricator must be installed in the air supply line. **Jarvis** part number 3346001 is available. *Keep the lubricator filled at all times.*

## OPERATION INSTRUCTIONS

 **ALWAYS DISCONNECT THE AIR HOSE IN ACCORDANCE WITH OSHA'S LOCKOUT/TAGOUT PROCEDURES (29 CFR 1910.147) BEFORE PERFORMING ANY MAINTENANCE OR REPAIRS.**

*Refer to Figure A on page 4 for referenced items.*

- 1 Connect air hose.

- 2 *Each day*, before you begin operation, go through the following checklist:

- 2.1 Make sure that the compressed air supply is at the proper pressure and that the lubricator is up to the full mark. (Use **Jarvis Air Mist Lubricator Oil**; if using a conventional air mist lubricator: set the feed rate at 8-10 drops per minute; if using a *micro fog* air mist lubricator\*: set the feed rate at 100 drops per minute). \*Almost all air mist lubricators are *micro fog* air mist lubricators.

- 2.2 Make sure the tool is working correctly. Depress the trigger and the claws should move into the frame. Release the trigger and the claws should move out of the frame. **If the tool malfunctions, remove it from service and report the problem to your supervisor immediately.**



- 2.3 Make sure that the PFI-1 moves freely on the balancer, if applicable.

- 3 Inserting the fingers. *Refer to Figure 1 as a guide.*



**THE PFI-1 IS NOT INTENDED FOR REMOVAL OF FINGERS. MISUSE OF THE TOOL CAN CAUSE INJURY AND DAMAGE THE TOOL.**

- 3.1 Insert rubber finger by hand through the hole in barrel drum or plate.

- 3.1.1 Pull finger by hand firmly against barrel drum or plate so that the finger will stay in place for the PFI-1 to grasp. *Note: Keep the finger dry. Do not use any oil or water as a lubricant on the finger.*

- 3.2 Place opened claws over entire rubber finger and press tool against barrel drum or plate, as applicable.

- 3.3 Press trigger to grasp and pull the finger.

- 3.3.1 Use the PFI-1 to grasp and pull the finger through the barrel drum or plate until groove of rubber finger seats into the hole of the barrel drum or plate. *Repeat this step if necessary.*

- 3.4 Release the trigger and remove the PFI-1.

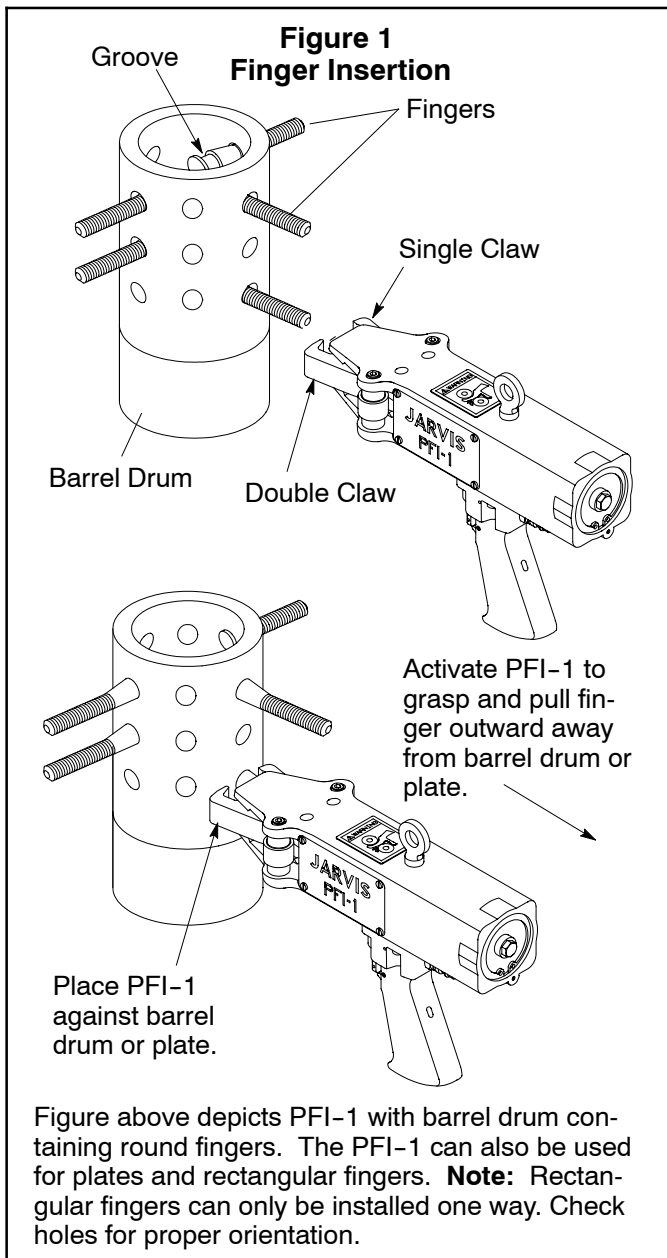

## MAINTENANCE INSTRUCTIONS



**ALWAYS DISCONNECT THE AIR HOSE IN ACCORDANCE WITH OSHA'S LOCKOUT/TAGOUT PROCEDURES (29 CFR 1910.147) BEFORE PERFORMING ANY MAINTENANCE OR REPAIRS.**

**DISSIPATE STORED ENERGY BEFORE PERFORMING ANY MAINTENANCE OR REPAIRS.**

Refer to Figure A on page 4 for referenced items.

1 DAILY: *Each day*, before you begin operation, go through the following checklist:

1.1 Make sure the control trigger is working correctly. *Depress* the trigger and the claws should move into the frame. *Release* the trigger and the claws should move out of the frame. ***If the tool malfunctions, repair or remove it from service immediately.***



***Connect the air hose to perform this operation only.***

1.2 Inspect all screws, nuts and fasteners and tighten or replace as necessary.

1.3 Inspect air hose and fittings for leaks and tighten or replace as necessary.

2 AS NECESSARY:

2.1 Disassemble, clean and inspect the PFI-1. *Refer to sections 3 through 12 as a procedural guide.*

3 CAM ROLLER REMOVAL:

3.1 Remove hex nuts (item 15), washers (item 16) and socket head screws (item 30).

3.2 Remove spacers (item 18) and cam rollers (item 19).

3.3 Clean and inspect all parts for wear and replace them if necessary.

4 CAM ROLLER ASSEMBLY:

4.1 Reverse steps and procedures outlined in section 3.

5 SINGLE AND DOUBLE CLAW REMOVAL:

5.1 Remove pan head screws (item 11) and guard plates (item 12) from both sides of frame and cylinder housing (item 17).

5.2 Remove cam rollers (item 19). *Refer to steps and procedures outlined in section 3.*

5.3 Extend the piston rod and yoke (item 22) so that retaining rings (item 27) or cotter pins (item 28) and pivot pins (item 24) are aligned with top and bottom holes of frame and cylinder housing (item 17).

- 5.4 Remove retaining rings (item 27) or cotter pins (item 28) and pivot pins (item 24). Use a pin punch to drive pivot pins out through holes in frame and cylinder housing (item 17).
- 5.5 Slide the single and double claws (items 29 and 26) and bushings (item 25) out from piston rod and yoke (item 22).
- 5.5.1 Remove the single and double claws and bushings out from either side of the frame and cylinder housing (item 17).
- 5.5.1.1 Remove the claws with the extension spring (item 23) still attached to both claws.
- 5.6 Remove extension spring (item 23).
- 5.7 Remove bushings (item 25) from single and double claws (items 29 and 26).
- 5.8 Clean and inspect all parts for wear and replace them if necessary.

6 SINGLE AND DOUBLE CLAW INSTALLATION:

- 6.1 Reverse steps and procedures outlined in section 5. See notes below. Refer to Figure 2 as a guide.
  - 6.1.1 Align holes in piston rod and yoke (item 22), bushings (item 25), and single and double claws (items 29 and 26) with the top and bottom holes of frame and cylinder housing (item 17) to install retaining rings (item 27) or cotter pins (item 28) and pivot pins (item 24).
  - 6.1.1.1 Slide pivot pins (item 24) through the holes using a drive pin to hold pivot pins in place while securing the retaining rings (item 27) or cotter pins (item 28) to them.
  - 6.1.1.2 Use a 1/4 inch nut driver to push retaining rings (item 27) securely onto pivot pins (item 24) or push cotter pins (item 28) with a flat screw driver blade.

7 PISTON AND SEAL REMOVAL:



**DISSIPATE STORED ENERGY FROM CYLINDER HOUSING BEFORE PERFORMING ANY MAINTENANCE OR REPAIRS.**

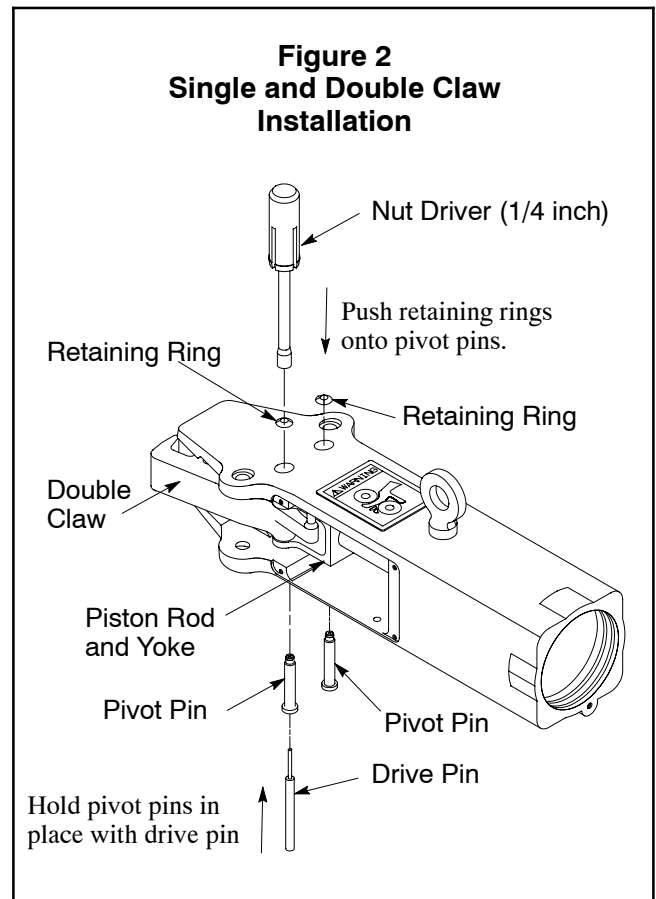

- 7.1 Disconnect hose from quick connect plug (item 3).
- 7.2 Slide piston rod and yoke (item 22) into frame and cylinder housing so that piston assembly (items 34 and 36) is all the way to the back end of the frame and cylinder housing (item 17).
- 7.3 Remove retaining ring (item 39) and end cap (item 38).
- 7.4 Remove o-ring (item 37), if necessary.
- 7.5 Remove hex nut (item 35).
- 7.6 Remove piston (item 34) and U-cup seals (item 36).
- 7.7 Clean and inspect all parts for wear and replace them if necessary.

## 8 PISTON AND SEAL ASSEMBLY:

- 8.1 Reverse steps and procedures outlined in section 7. *See notes below.*
- 8.2 Apply a generous amount of **Jarvis 1315 White Grease** to U-cup seals (item 36) before installing back into frame and cylinder housing (item 17).
- 8.3 Make sure that the flat surface of U-cup seals (item 36) are facing each other.
- 8.4 Apply *Loctite 262* to threads of hex nut (item 35) before tightening.
- 8.5 Make sure retaining ring (item 39) is seated properly into groove of frame and cylinder housing (item 17).

## 9 PISTON ROD AND SEAL REMOVAL:

- 9.1 Remove cam rollers (item 19). *Refer to steps and procedures outlined in section 3.*
- 9.2 Remove single and double claws (items 29 and 26). *Refer to steps and procedures outlined in section 5.*
- 9.3 Remove piston and U-cup seals (items 34 and 36). *Refer to steps and procedures outlined in section 7.*
- 9.4 Slide piston rod and yoke (item 22) out from the front end of frame and cylinder housing (item 17).
- 9.5 Remove U-cup seal (item 20) from inside the front end of frame and cylinder housing (item 17).
- 9.6 Remove o-ring (item 21), if necessary.
- 9.7 Clean and inspect all parts for wear and replace them if necessary.

## 10 PISTON ROD AND SEAL ASSEMBLY:

- 10.1 Reverse steps and procedures outlined in section 7. *See notes below.*
- 10.2 Apply a generous amount of **Jarvis 1315 White Grease** to U-cup seal (item 20) before installing into frame and cylinder housing (item 17).
- 10.3 Make sure flat surface of U-cup seal (item 20) is facing toward the front end of frame and cylinder housing (item 17).
- 10.4 Follow steps and procedures outlined in section 8.

- 10.5 Follow steps and procedures outlined in section 6.

## 11 TRIGGER VALVE ASSEMBLY REMOVAL:

- 11.1 Remove set screw (item 6) from handle (item 4).
- 11.2 Remove trigger and valve assembly (item 10) from handle.
- 11.3 Remove compression spring (item 8).
- 11.4 Remove set screw (item 7) from handle (item 4).
- 11.5 Remove valve bushing from handle (item 4). Use **Jarvis** special tool (part number 8330024) to remove and install valve bushing.
- 11.6 Clean and inspect all parts for wear and replace them if necessary. **NOTE: If any part of trigger valve assembly needs to be replaced, the whole valve assembly must be replaced. Do not mix old and new parts.**

## 12 TRIGGER VALVE ASSEMBLY INSTALLATION:

- 12.1 Reverse steps and procedures outlined in section 9. *See notes below.*
- 12.2 Keep trigger and valve assembly (item 10) and handle (item 4) clean from any dust or dirt.
- 12.3 Make sure trigger and valve assembly is installed as a set. **Do not mix old and new parts.**
- 12.4 Apply a light coat of **Jarvis 1315 White Grease** to trigger and trigger valve sleeve before installing into handle.
- 12.5 Make sure o-rings (item 9) are set properly in grooves of trigger valve sleeve when installing into handle.
  - 12.5.1 Apply a light coat of grease around o-rings to help keep them in place and to help slide trigger valve sleeve into handle, if necessary.
- 12.6 Use **Jarvis** special tool (part number 8330024) to align trigger valve sleeve into handle (item 4). *See note below.*
  - 12.6.1 Align air passage holes (facing upward) of trigger valve sleeve with air passage holes of handle. **Make sure indent (spot face) in valve sleeve aligns with set screw (item 7).**