

# SCREW PUMPS

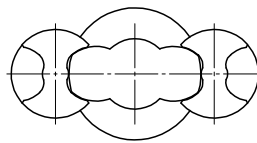

# Leistritz

Range	Type	Size	Pitch	Shape	Type of Seal	Identification
L3M L3H	F	025-090	/...	IFOKSO	W G	3 SPINDLE FLANGE PUMP WITH SUCTION HOUSING BALL BEARING INSIDE

suction side:

flange connection SAE J518c 3000 PSI

discharge side:

flange connection SAE J518c 3000 PSI

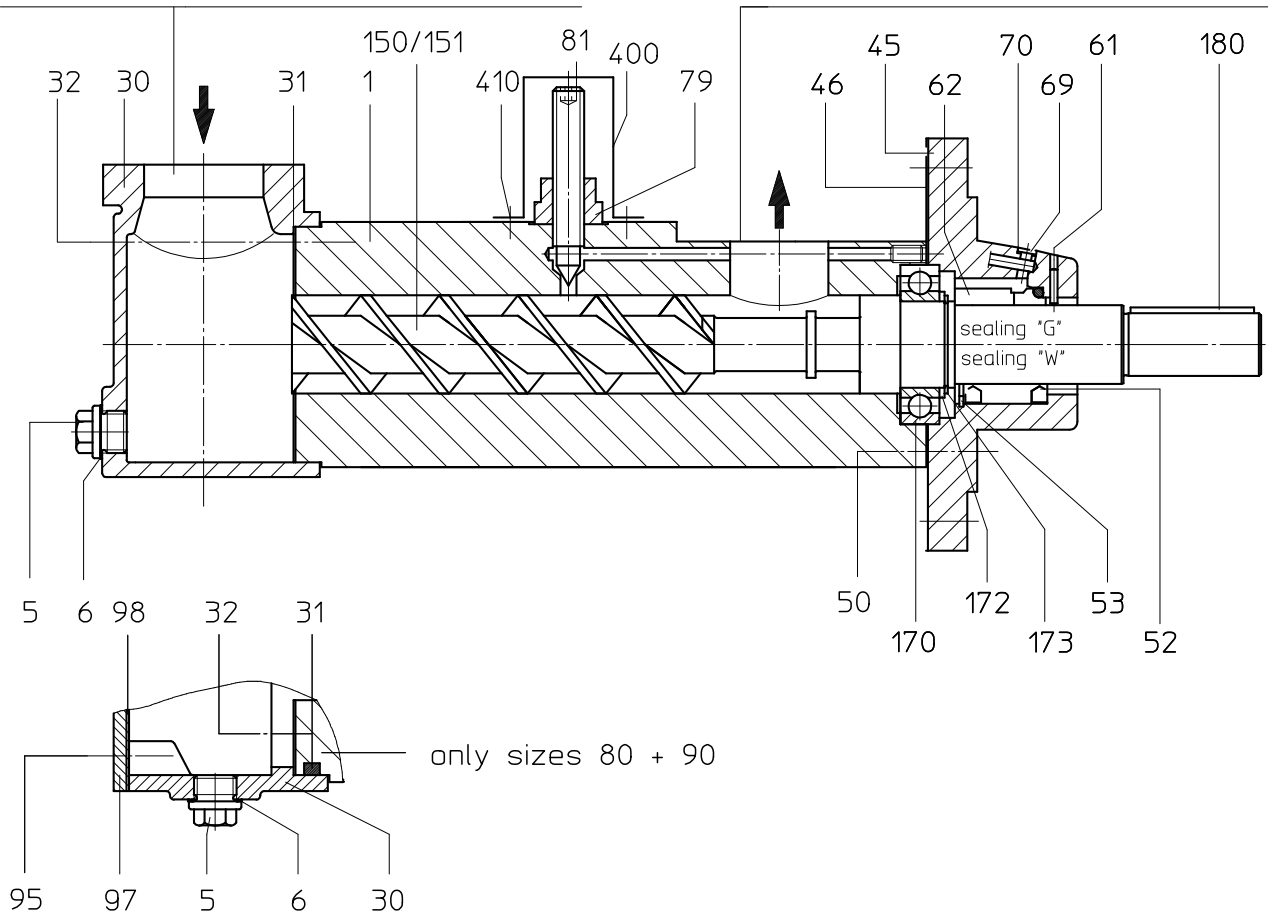

- |                       |                           |                              |
|-----------------------|---------------------------|------------------------------|
| ● 1 pump casing       | ● 50 mounting screw       | ● 95 mounting screw          |
| ● 5 locking screw     | ● ○ 52 shaft sealing ring | 97 end cover                 |
| ● 6 sealing ring      | ● ○ 53 circlip            | ○ 98 gasket                  |
| 30 suction housing    | ● 61 edged adjusting pin  | ○ 150 driving spindle        |
| ○ 31 gasket           | ○ 62 mechanical seal      | ○ 151 idler spindle          |
| ● 32 mounting screw   | ● 69 locking screw        | ● ○ 170 grooved ball bearing |
| 45 driving side cover | ● 70 sealing ring         | ● 172 supporting disk        |
| ○ 46 gasket           | ● ○ 79 seal-lock nut      | ● ○ 173 circlip              |
|                       | 81 adjusting screw        | ● ○ 180 key                  |
|                       |                           | 400 safety bow               |
|                       |                           | 410 mounting screw           |

Rev. 001  
23.06.93  
Bimüller

Projektionsmethode 1



- norm parts
- spare parts

Edition: June 1993

Subject to modification.

Rev. 001