

# SM\* TURRETS

# TRM-S TURRETS

# FL TURRETS

## CONTROL UNIT DDC4-30-230/20

## CONTROL UNIT DDC4-20-230/20

FW: 2.4/2.6/2.88/2.9/3.0/4.0

## INSTALLATION MANUAL

Correspondence between electronic unit code and software

### Turrets SM/TRM-S/FL

Control Unit	HW code	Parameter set from release	Table	Turret	Inertia max. (kgm <sup>2</sup> )	
					Liv. 1	Liv. 2
DDC4-20-230/20	0496304*	0489103-4	0	Reserved		
DDC4-20-230/20	0496304*01	0489103-4	1	SM-*-12.....230V	0,8	1,2
DDC4-20-230/20	0496304*02	0489103-4	2	Not used		
DDC4-20-230/20	0496304*03	0489103-4	3	SM-*-16.....230V	1,2	2,2
DDC4-20-230/20	0496304*04	0489103-4	4	Not used		
DDC4-20-230/20	0496304*05	0489103-4	5	SM-*-20.....230V	3	5
DDC4-20-230/20	0496304*06	0489103-4	6	SM-*-20.....230V	5	9
DDC4-20-230/20	0496304*07	0489103-4	7	SM-*-25.....230V	5	9
DDC4-20-230/20	0496304*08	0489103-4	8	SM-*-25.....230V	9	14
DDC4-20-230/20	0496304*09 0496329*09	0489103-5	9**	SM-*-32	15	22
DDC4-20-230/20	0496304*10	0489103-4	10	Not used		
DDC4-20-230/20	0496304*11	0489103-4	11	TRMS-250...230V	10	
DDC4-20-230/20	0496304*12	0489103-4	12	TRMS-320...230V	25	
DDC4-10-230/20	0496304*13	0489103-4	13	TRMS-400...230V	60	100
DDC4-20-230/20	0496304*14	0489103-4	14	FL-16...230V/CL*16	1,4	2,5
DDC4-20-230/20	0496304*15	0489103-4	15	Not used		
DDC4-20-230/20	0496304*16	0489103-4	16	SM-*-16.....230V	2,2	3,5
DDC4-20-230/20	0496304*17	0489103-4	17	Not used		
DDC4-20-230/20	0496304*18	0489103-5	18**	Reserved for SM-*-10.....230V	0,15	0,30

\*: number of tools

A=8/12; B=6/12; C=12/24; D=8/16; E=12/16; F=5/10; G=4/8; H=16/12

\*\* : only starting from FW 2.88 and parameter set 0489103-5

**Turrets SMA/SMB\*M**

Control Unit	HW code	Parameter set from release	Table	Turret	Inertia max. (kgm <sup>2</sup> )	
					Liv.1	Liv.2
DDC4-30-230/20	0496302*	0489102-4	0	reserved		
DDC4-30-230/20	0496302*01	0489102-4	1	Not used		
DDC4-30-230/20	0496302*02	0489102-4	2	Not used		
DDC4-30-230/20	0496302*03	0489102-4	3	SMA-*-16.....230V	1,2	2,2
DDC4-30-230/20	0496302*04	0489102-4	4	Not used		
DDC4-30-230/20	0496302*05	0489102-4	5	SMA-*-20.....230V	2,6	5
				SM-B 16	2,6	
				SM-B 20		5
DDC4-30-230/20	0496302*06	0489102-4	6	SMA-*-20.....230V	5	9
DDC4-30-230/20	0496302*07	0489102-4	7	SMA-*-25.....230V	5	9
				SM-B25		9
DDC4-30-230/20	0496302*08	0489102-4	8	SMA-*-25.....230V	9	14
DDC4-30-230/20	0496302*09	0489102-4	9	Not used		
DDC4-30-230/20	0496302*10	0489102-4	10	Not used		
DDC4-30-230/20	0496302*11	0489102-4	11	Not used		
DDC4-30-230/20	0496302*12	0489102-4	12	Not used		
DDC4-30-230/20	0496302*13	0489102-5	13	TRM-S- 400 (**)	30	60
DDC4-30-230/20	0496302*14	0489102-4	14	FL-16...230V	1,4	2,5
DDC4-30-230/20	0496302*15	0489102-4	15	Not used		
DDC4-30-230/20	0496302*16	0489102-4	16	Not used		

\*: number of tools

A=8/12; B=6/12; C=12/24; D=8/16; E=12/16; F=5/10; G=4/8; H=16/12

\*\* Turret managed starting from parameter file 0489102-5

**Update list rel. 0106:**

- 1) updated parameter set
- 2) Added LED position /description
- 3) Update drawing of cable from e. cabinet to connection box (wrong number on some pin)
- 4) Updated drawings to better identify pin 1 on 2 poles phoenix connectors.

**Update list rel. 1009:**

- 1) updated parameter set (new turrets)
- 2) updated FW releases
- 3) updated EMC and WEEE chapters
- 4) Changed alarm 7.3 description
- 5) added drawings for turret with connectors
- 6) added description of LEDs on mainboard

**Update list rel. 0510:**

- 1) cleared some errors in wire names at page 35 and 36

**Update list rel. 1015:**

- 1) Added new software and parameters releases.

The information described in this manual may be subject to variations due to technical modifications.  
**DUPLOMATIC AUTOMATION S.r.l.** reserves the right to modify the contents of this manual without prior notice.

## Contents

<b>1. GENERAL INFORMATION</b>	<b>5</b>
CODE OF THE CONTROL UNIT	5
IMPORTANT NOTE FOR SAFETY	6
ROHS AND WEEE DIRECTIVE	6
CE COMPLIANCE	7
CHARACTERISTICS OF THE CONTROL UNIT	8
TECHNICAL CHARACTERISTICS OF THE CONTROL UNIT	8
<b>2. ELECTRICAL CONNECTIONS</b>	<b>9</b>
SUPPLY	9
POWER SUPPLY 230 VAC 3 $\Phi$	9
SUPPLY 24 VDC FOR CONTROLLER SECTION	9
POWER SUPPLY 24VDC FOR I/O	9
TECHNICAL SPECIFICATIONS FOR POWER TRANSFORMER DESIGN	9
I/O SIGNALS	10
OUTPUTS TO CNC (FROM I/O)	10
OUTPUTS TO ELECTROVALVE (FROM I/O)	10
INPUTS FROM CNC (TO I/O)	10
INPUTS FROM TURRET (TO DRIVER)	10
CONFIGURATION SELECTORS (TO I/O)	10
SELECTION OF THE NUMBER OF POSITIONS	11
SELECTION OF LOW/HIGH INERTIA	11
SELECTION OF STANDARD/MAINTENANCE SPEED	11
<b>3. INTERFACING TO CNC</b>	<b>12</b>
OPERATING FUNCTIONS	12
ZERO SEARCH	12
OPERATING FUNCTIONS DESCRIPTION	13
OPERATING FUNCTION N°0: EMERGENCY / RESET	15
OPERATING FUNCTION N°1,2,3: AUTOMATIC	15
OPERATING FUNCTION N°4: JOG	16
OPERATING FUNCTION N°5: SERVICE	16
OPERATING FUNCTION N °7: SAFETY	17
<b>4. DIAGNOSTIC</b>	<b>19</b>
ALARMS AND WARNINGS	19
EXTENDED ALARM DESCRIPTION/TROUBLESHOOTING	20
<b>5. SCHEMATICS AND DRAWINGS</b>	<b>22</b>
DESCRIPTION OF DDC4 ELECTRICAL CONNECTIONS	22
POWER CONNECTIONS	22
SIGNAL CONNECTIONS	23
LED POSITION AND MEANINGS	24
FITTING INTO THE ELECTRICAL CABINET	25
OVERALL DIMENSIONS	25
GENERAL DRAWING FOR FITTING INTO THE ELECTRICAL CABINET	26
GENERAL DRAWING FOR FITTING INTO THE ELECTRICAL CABINET (TURRET WITH CONNECTORS)	27
SERVOMOTOR CABLE FOR FITTING INTO THE ELECTRICAL CABINET	28
SERVOMOTOR CABLE (TURRET WITH CONNECTORS)	28
SERVOMOTOR CABLE (TURRET WITH CONNECTORS)	29
RESOLVER/SWITCHES CABLE FOR FITTING INTO THE ELECTRICAL CABINET.	30
RESOLVER/SWITCHES CABLE (TURRET WITH CONNECTORS).	30
RESOLVER/SWITCHES CABLE (TURRET WITH CONNECTORS).	31
DRIVER SUPPLY FOR FITTING INTO THE ELECTRICAL CABINET	31
DRIVER SUPPLY FOR FITTING INTO THE ELECTRICAL CABINET	32
DIGITAL INPUT AND OUTPUT FOR FITTING INTO THE ELECTRICAL CABINET	33
FITTING INTO THE TURRET	34
CONNECTION BOX FOR FITTING INTO THE TURRET	34
CABLES FROM THE ELECTRICAL CABINET TO THE CONNECTION BOX	34





CABLES FROM THE ELECTRICAL CABINET TO THE CONNECTION BOX	35
INTERNAL WIRING FOR FITTING INTO THE TURRET	36
TIME DIAGRAM	37
SERVICE SERIAL CONNECTION	38

## 1. GENERAL INFORMATION

The Duplomatic control unit is a compact system that controls all functions regarding positioning and driving of the **SM\* turrets Duplomatic**. The interfacing to the lathe is powerful and simplified for an easy installation. Serial line RS232 is set for diagnostic and remote control by PC.

### CODE OF THE CONTROL UNIT

 		
DIPLOMATIC AUTOMATION		
MADE IN ITALY		
Model: DDC4-20-230/20		
Code: 0496304A03		
S/N *****		
DSP FW 2.8		
I/O FW 5		
TABLE SET	0489103	
TABLE SELECT	3-SM16	
INERTIA	LEV.1	LEV.2
J (kgm <sup>2</sup> )	1,2	2,2
PTAB03	24V	0V
TOOLS	8	12
PTAB01	24V	0V
PTAB02	0V	24V

All information concerning the controller configuration are printed on a label like this one. It is possible to read the code, the FW release, the parameter set loaded and the actual configuration, with the turret model and the allowed inertia. The configuration of selectors PTAB01, PTAB02, PTAB03 and their effects are also stated.

Sometimes the S/N of the controller is printed on a separate white label.

The code of DDC4 controller is composed by 7 digits to describe the **HARDWARE**, and a letter to describe the actual number of handled tools followed by two digits to indicate the parameter table loaded (related to turret size and inertia).

For example, in this label we have a DDC4 code 0496304 (for SM\*-230V turret) set for 8 or 12 tools (letter A, to be chosen by applying 24V to PTAB01 or to PTAB02) and set to drive a turret SM-16 (table 03).

The allowed inertia of the tooldisc can be 1,2 kgm<sup>2</sup> or 2,2 kgm<sup>2</sup> according to the voltage on input PTAB03. The list of turret configured is printed at the beginning of the manual. Other settings are available on request.

**IMPORTANT NOTE FOR SAFETY**

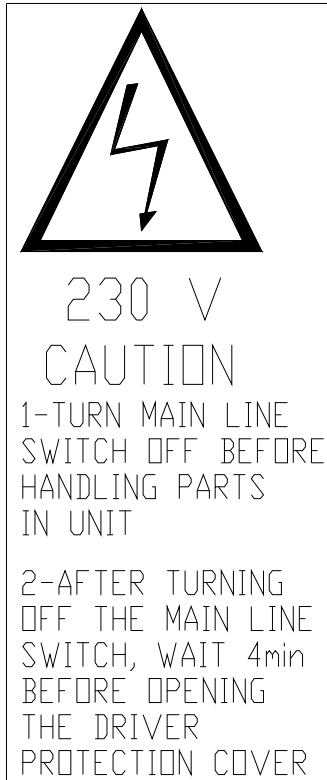

**Do not manipulate the inside of the unit**

Only personnel authorized by Duplomatic may manipulate the inside of this unit.

**Do not manipulate the connectors with the unit connected to AC power.**

Before manipulating the connectors (inputs/outputs, feedback, etc.) make sure that the unit is not connected to AC power.

The control unit, even after the power off of the supply, stores internally electric power until the power capacitors are charged.

**Be careful when operate on it.**

**ROHS AND WEEE DIRECTIVE**

The DDC4 control unit does not belong to the scope of RoHS and WEEE directive, being used only on large an fixed machine. By the way since the beginning of 2007 the DDC4 is manufactured according to RoHS compliant processes. Some repaired spare part can still be delivered in non-RoHS configuration.

## **CE COMPLIANCE**

The DDC4 controller belongs to the international product standard EN 61800.

The DDC4 controller has been tested with a turret under the condition reported as follows and obtained the compliance for product standards: CEI EN 61800-2 and CEI EN 61800-3 and CEI EN 61800-5-1.

The utilization class for this device is C3 (use in 'second environment' or use in industrial network line not connected to civil environment).

This type of device is not intended to be used on a low-voltage public network which supplies domestic premises. Radio frequency interference is expected if used on such a network.

Therefore, the use in civil environment could generate disturbance to some electrical and electronic equipment and it needs to provide additional solutions to avoid this effect.

Before main voltage power supply of DDC4 controller, an external filter (non supplied) is necessary for EMC compliance when DDC4 controller + turret are tested as stand-alone component.

A 'ROXBOROUGH KMF06' EMC filter or better must be used.

The DDC4 controller, being transistorised drive for brushless motor, is not a safety device, and cannot work in stand-alone mode because requires supply and wiring by the installer. So it is not subject to the CE mark requirement.

By the way the CE mark is placed to show the compliance to the low-voltage directive about the electrical safety of the component. The compliance of EMC and general safety standard is in charge of the machine builder as stated also in the 2006/42/CE directive. The instruction stated in this installation manual provide a line-guide to keep the EMC compliance in almost all applications.

In order to comply with the EN-61800-5-1 it needs to respect what follows:

- The DDC4 controller must be connected in a TT or TN earthing system in industrial fixed network, providing Overvoltage Category III or better.
- The DDC4 controller must be fitted into a cabinet which provide Pollution Degree II or better, so a minimum protection degree of IP54 is required.
- An external circuit breaker (Fuses) and a power contactor must be provided on the DDC4 threephase main power supply.
- The cabinet must be designed in order to protect people against direct contact when the voltage is present: so mechanical interlock or automatic door-open switch-off devices must be foreseen.
- After power-off, wait more than 5 minutes before handling the DDC4 controller.

## CHARACTERISTICS OF THE CONTROL UNIT

- Best path research.
- External selection of rotation direction.
- Automatic reference search.
- Parity control on position code.
- Enhanced diagnostic.
- Selection of two ranges of positions (eg. 8 and 12 or 6 and 12) with dedicated inputs.
- Selection of inertia on disc with dedicated input.
- Speed reduction for maintenance purposes with dedicated input.
- 'Safety' behaviour can be set by CNC or PC.

The entire unit is insulated from the external with optoinsulators to satisfy safety standards. Parameters of the system are optimised and cannot be modified by the customer.

## TECHNICAL CHARACTERISTICS OF THE CONTROL UNIT

<b>DRIVER SECTION SUPPLY</b>	
Power input <b>3 Φ</b>	230V +15% - 10 % 50/60Hz ±2Hz 3 Φ 30 A max. (DDC4-30-230) 20 A max (DDC4-20-230)
Auxiliary input <b>DC</b>	24V DC±10% 35W

tab 1

<b>Supply for I/O</b>	
<b>DC SUPPLY</b>	24V DC±10% 5A max.
<b>Digital inputs</b>	Sink 24 VDC ±10% 5 mA @ 24 VDC
<b>Digital outputs</b>	<ul style="list-style-type: none"> <li>• Transistor MOS N.O. (Source)</li> <li>• 0.1 A max (PTC protection)</li> </ul>
<b>Electrovalve</b>	<ul style="list-style-type: none"> <li>• Transistor MOS N.O. (Source)</li> <li>• 2A max (PTC protection)</li> </ul>

tab 2

<b>General specifications</b>	
<b>Operative Temperature</b>	0 ÷ 55 °C
<b>Humidity</b>	30.. 95%
<b>Vibrations</b>	4G RMS (for short period) 0,5 RMS (continuously)

tab 3

## 2. ELECTRICAL CONNECTIONS

Refer to the annex diagrams at section 5:

1. : wiring diagrams for installation into the electrical cabinet.
2. : wiring diagrams for installation into the turret

### SUPPLY

#### POWER SUPPLY 230 VAC 3 $\Phi$

(see tab1)

The control unit requires a three-phase 230 VAC input for the power section (at connector CN11).

A power contactor on the 230 AC line must be used for emergency stop and for safe disable (see wiring diagram). The 230 VAC line must be protected with external fuses 6 A T.(suggested 4-6.3 A motor start).

An external filter is required to meet E.M.C. compliance (optional).

#### SUPPLY 24 VDC FOR CONTROLLER SECTION

(see tab1)

The control unit requires an external 24V DC supply at CN8 to build up all auxiliary supply necessary for the driver section. An external slow-type fuse of 1 A must be used to protect this supply. A polarity inversion does not damage the controller.

#### POWER SUPPLY 24VDC FOR I/O

(see tab 2)

The I/O section is galvanically insulated from the driver section and therefore requires a second 24 V DC source on CN3. The max current consumption is related on the load on its outputs and is about 3,5 A in case of all outputs ON. Every output is PTC protected. A fast fuse rated 4 A is a good protection for the supply cable. The protection against wrong polarity of supply is performed by diodes in counter-parallel. This protection is effective only if a fuse is present on the supply cable.

### TECHNICAL SPECIFICATIONS FOR POWER TRANSFORMER DESIGN

Rated primary voltage	Variable
Secondary rated voltage	230 VCA $\pm$ 10% 3 $\Phi$
Rated Power	1200 VA
Max voltage drop at 10 A rms (during acceleration)	5%
Connection	star-star or delta-star
Secondary voltage deviation	$\pm$ 2%

tab 4

**Important:** check the voltage drop on the 230 VAC supply during acceleration, to be sure that this doesn't approach the indicated voltage limits.

## **I/O SIGNALS**

### **OUTPUTS TO CNC (FROM I/O)**

**LOCKED:** turret locked.

**INDEXD:** turret in position (can be used to start axis movement).

**ALBIT1, ALBIT2, ALBIT4:** alarm codes.

**ALPOS1, ALPOS2, ALPOS4, ALPOS8, ALPOS16:** current tool or secondary alarm code.

### **OUTPUTS TO ELECTROVALVE (FROM I/O)**

**EVLOCK:** locking valve.

**EVULCK:** unlocking valve.

### **INPUTS FROM CNC (TO I/O)**

**PBIT01, PBIT02, PBIT04, PBIT08, (PBIT16):** position code bits.

**PARITY:** parity for position codes.

**PSTART:** signal for starting turret cycle.

**MODE01, MODE02, MODE03:** mode select code bits.

**SPDSEL:** selection of standard or maintenance speed.

### **INPUTS FROM TURRET (TO DRIVER)**

**LOCKSW:** turret locked switch.

**ULCKSW:** turret unlocked switch (rotation free-not present in SMH-32).

**ZEROSW:** turret reference switch (home switch).

**MOTOVL:** thermal detector switch of the motor (normally closed).

**INPUT1:** spare input (foreseen for MDT application).

**INPUT2:** spare input (foreseen for MDT application).

### **CONFIGURATION SELECTORS (TO I/O)**

**PTAB01, PTAB02:** set 8/12 positions.

**PTAB03:** set low/high inertia.

### SELECTION OF THE NUMBER OF POSITIONS

The turret can be easily configured for two different number of positions simply setting two digital inputs of the control units. No mechanical operations or part replacement are required. The value of the two settings can be changed by PC.

Software	8/12 tools		6/12		12/24		8/16	
Tools N°	8	12	6	12	12	24	8	16
<b>PTAB01</b>	24VDC	0VDC	24VDC	0VDC	24VDC	0VDC	24VDC	0VDC
<b>PTAB02</b>	0VDC	24VDC	0VDC	24VDC	0VDC	24VDC	0VDC	24VDC

The PTAB01 or PTAB02 must be set at controller switch-on otherwise the turret cannot start and **ALARM 77** appears.

### SELECTION OF LOW/HIGH INERTIA

The turret can be easily configured to drive two ranges of inertia just setting a signal in the control unit. No mechanical operations or part replacement are required

	<b>Standard inertia (LEVEL 1)</b>	<b>High inertia (LEVEL 2)</b>
<b>PTAB03</b>	connected to 24VDC	not connected

### SELECTION OF STANDARD/MAINTENANCE SPEED

This input can be used to slow-down immediately the turret in front of dangerous operations (door opening, maintenance operations). The speed is about the 20% of the nominal speed.

Connect the SPDSEL input to the 24VDC supply if not used. If the maintenance speed is set during the movement, it is kept until the end of positioning.

	<b>Standard speed</b>	<b>Maintenance speed</b>
<b>SPDSEL</b>	connected to 24VDC	not connected

### 3. INTERFACING TO CNC

#### OPERATING FUNCTIONS

The control unit offers several operating functions (also called MODES).

Setting MODE01, MODE02, and MODE03 signals can make the selection of the operating functions.

N°	OPERATING FUNCTIONS	INPUTS			DESCRIPTION
		MODE01	MODE02	MODE03	
0	Emergency/ Reset	0	0	0	Setting this mode will stop immediately the turret. Alarms can be reset setting this mode and then setting another mode.
1	Automatic shortest path	1	0	0	The turret will use the shortest path to reach the position required.
2	Automatic CW	0	1	0	The turret will always use the CW direction path to reach the position required.
3	Automatic CCW	1	1	0	The turret will always use the CCW direction path to reach the position required.
4	Jog, next tool in CW or CCW	0	0	1	The turret will reach the next position.
5	Service	1	0	1	Enables a series of functionality to simplify the start-up phase and troubleshooting
6		-	-	-	RESERVED
7	Safety	1	1	1	Enables a series of functionality to overcome conditions that normally would stop the turret for a long time.

#### ZERO SEARCH

After any power-on of the control unit (24V DC auxiliary supply) the turret must execute the reference cycle.

At the end of the reference cycle the turret is locked in position 1.

To execute the reference cycle proceed as follows

1. Set an automatic function (1,2 or 3)
2. Set this code.

POSITION	PARITY	PBIT01	PBIT02	PBIT04	PBIT08	(PBIT16)
Zero cycle	0	0	0	0	0	0

3. Set impulsive **PSTART** to reach out the zero position (**PSTART** must stay on for more than 30 ms).
4. Wait 500 ms after INDEXD and LOCKED signals give the end of the cycle.

**OPERATING FUNCTIONS DESCRIPTION**

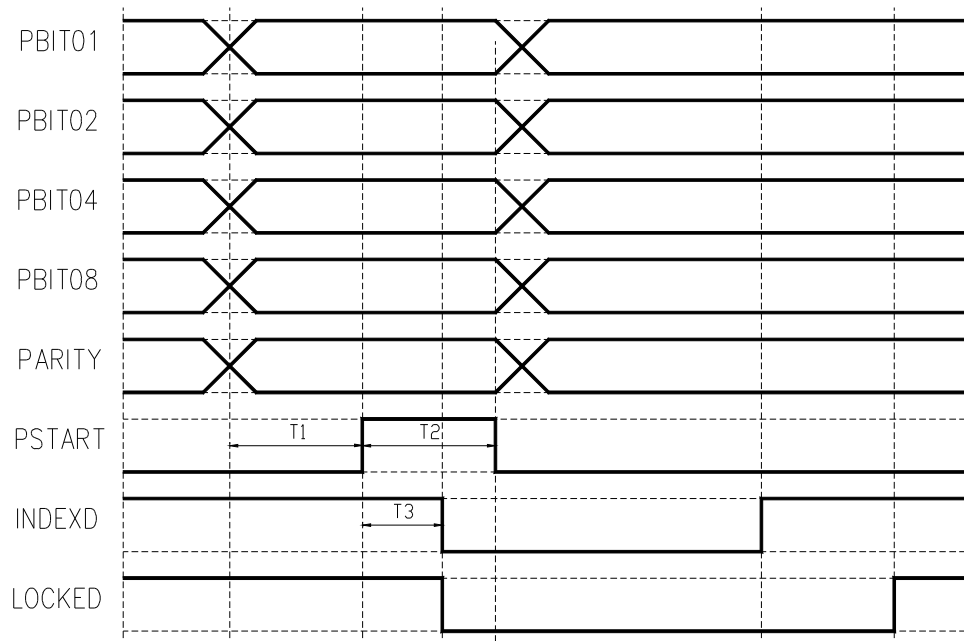

**AUTOMATIC OPERATING FUNCTIONS (1,2,3)**

- Set the code of the position required.
- Wait until the position code output is stable (it depends on what type of PLC/CNC outputs are used - relay, static...).
- Give the PSTART command (active on its rising front). PSTART must stay ON for more than 30 ms (T2).
- The turret confirms the reception of the start signal by setting low both INDEXD and LOCKED signal after approximately 30 ms (T3). The current position (ALPOSxx signals) is also set to 0.
- When the position requested has been reached, but the disc is not yet locked, the INDEXD signal is set high (this signal can be used to start the approach of the tool to the part to be worked on). In the same time the turret current position outputs (ALPOSxx) are set to the new position value.
- After the disc has been locked, the LOCKED signal is set to high. The turret can work. It is possible to make a cross-check among the current position and the called one because all signals are stable.
- Position bits and parity bit must be stable for at least 30 ms. from PSTART signal. After this time and once the turret confirmed the start reception, position bits, parity bit, and start signal can be changed until the INDEXED signal is low. **However it is strongly recommended to keep position bits and parity code set to the last position called.**
- The PSTART signal can be reset after the confirmation of the reception, typically it must stay on for at least 30 ms (T2).

**Important: the end of cycle must be detected by the LOCKED signal that changes from low to high and with the INDEXD signal high and no alarms are present.**

**SAME TOOL CALL**

In case of the turret is already in the position called (for example change in tool offset T1.01 ..T1.02) the turret will not move or unlock/lock but the INDEXD and LOCKED signals will have the same behaviour as a normal rotation (INDEX and LOCKED low after the PSTART and then after approx. 200ms the INDEX goes HIGH and after 50 ms more the LOCKED signal goes HIGH).

## INDEXD SIGNAL

The INDEXD signal must be used with the LOCKED signal to detect the end of cycle of the turret and can be ignored once the turret is locked.

The INDEXD output goes and stay LOW also when the emergency mode is set and if the three-phase power supply is OFF.

In this case, if the turret management from PLC/CNC uses the emergency mode or open the power contactor, the INDEXD signal must be used only when the turret is in cycle and then ignored.

The CNC/PLC program must check the LOCKED signal while the turret is not in cycle: if this signal goes LOW stop immediately the machine and check the cause.

## ALARM CONDITIONS

When an alarm condition is detected, one or more of the ALBIT1, ALBIT2, ALBIT4 is high and the INDEXD signal is low.

When at least one of ALBITxx is HIGH, ALPOSxx outputs give the second digit of the alarm code.

**In this case the machine must be immediately stopped** and the three-phase power contactor should be opened.

Important: the turret can show alarms in any time (also if it is not on cycle) so **check always the alarm output of the turret.**

## JOG MODE

If the ALPOSxx outputs are not used, the CNC does not know the actual turret position based only on the memory of the last position called. The Jog mode does not require to set the next position number but just ask the turret to go in the next/previous one. Be sure to not show in the screen of CNC a tool position different from the reality.

## EXCESSIVE ELECTRICAL NOISE OR BAD WIRING DETECTION (not active from FW 2.6))

If the turret is not in cycle and in automatic mode, any variation in POSITION BITS and PARITY must be followed by the PSTART signal.

If the PSTART does not come in about 5 seconds (T1) an alarm 7 (73) is output from the turret.

Avoid to change the position code just after the turret LOCKED signal goes high (end of cycle) because this can be detected as a new position request.

See the diagnostic section to have more details.

## AUTOMATIC RECOVER FOR PRESSURE/VALVES PROBLEMS

The turret will attempt three times to lock or unlock before giving an alarm (41 or 51).

If the operator hear the valve operated more times during the tool change it is necessary to check the cause of the problem and remove it before a permanent failure happens.

## OPERATING FUNCTION N°0: EMERGENCY / RESET

OPERATING FUNCTION N°0	INPUTS		
	MODE01	MODE02	MODE03
Emergency/reset	0	0	0

This operating function has two purposes:

- 1) Stop all turret movement (**EMERGENCY**).
- 2) Acknowledge all alarms, if they are present (**RESET**).

It must stay on for more than **30 ms** to be read by the control unit. It isn't necessary to carry out a RESET to go into or out operating function. Meanwhile, the transition from one operating function to the other could generate a transitory condition that can be detected as an emergency request.

The INDEX signal goes low after a RESET.

The alarm output will be cleared changing from operating function N°0 to another operating function (e.g. Automatic).

In any case, after changing from mode 0 to any other mode, **it is necessary to wait 800 ms before any variation of PSTART signal.**

## OPERATING FUNCTION N°1,2,3: AUTOMATIC

These operating functions are normally used to drive the turret.

Just set the code of the position required, give the start signal and the turret will automatically reach the position.

1. Clear all alarms (if present);
2. Set an automatic function:

OPERATING FUNCTION N°1,2,3	INPUTS		
	MODE01	MODE02	MODE03
Automatic with shortest path search	1	0	0
Automatic CW	0	1	0
Automatic CCW	1	1	0

3. Set the position code: (use PBIT16 only for turrets with 16 tools or more).

CODE	POSITION												
	Zero Cycle	1	2	3	4	5	6	7	8	9	10	11	12
PBIT01	0	1	0	1	0	1	0	1	0	1	0	1	0
PBIT02	0	0	1	1	0	0	1	1	0	0	1	1	0
PBIT04	0	0	0	0	1	1	1	1	0	0	0	0	1
PBIT08	0	0	0	0	0	0	0	0	1	1	1	1	1
(PBIT16)	0	0	0	0	0	0	0	0	0	0	0	0	0
PARITY	0	1	1	0	1	0	0	1	1	0	0	1	0

CODE	POSITION												
		13	14	15	16	17	18	19	20	21	22	23	24
PBIT01		1	0	1	0	1	0	1	0	1	0	1	0
PBIT02		0	1	1	0	0	1	1	0	0	1	1	0
PBIT04		1	1	1	0	0	0	0	1	1	1	1	0
PBIT08		1	1	1	0	0	0	0	0	0	0	0	1
(PBIT16)		0	0	0	1	1	1	1	1	1	1	1	1
PARITY		1	1	0	1	0	0	1	0	1	1	0	0

4. Set **PSTART** for give the confirmation of the movement within 5 s.  
(It must stay ON for more than 30 ms).

### OPERATING FUNCTION N°4: JOG

The disc will rotate of one step in the selected direction.

Proceed as follows

1. Clear all alarms (if present);
2. Set the operating function:

OPERATING FUNCTION N°4:	INPUTS		
	MODE01	MODE02	MODE03
Next station in CW or CCW	0	0	1

3. Select direction:

	PBIT01	PBIT02
Rotation in CW	1	0
Rotation in CCW	0	1

4. Set **PSTART** for give the confirmation of the movement in 5 s.  
(It must stay ON for more than 30 ms).

### OPERATING FUNCTION N°5: SERVICE

The turret cycle can be executed "step by step": unlocking, rotation, locking.

Proceed as follows

1. Clear all alarms (if present);
2. Set an operating function:

OPERATING FUNCTION N°5:	INPUTS		
	MODE01	MODE02	MODE03
Service	1	0	1

3. Select a command:

	PBIT01	PBIT02	PBIT04	PBIT08	PARITY
Locking	0	0	1	0	0
Unlocking	0	0	0	1	0
Next tool CW	1	0	0	0	1
Next tool CCW	0	1	0	0	1
Continuos rotation CW	1	0	0	0	0
Continuos rotation CCW	0	1	0	0	0

4. Set **PSTART** for give the confirmation of the movement within 5 s.  
(It must stay ON for more than 30 ms).

Locking and unlocking don't require **PSTART** signal.

The unclamping function keeps the motor enabled, so it is necessary to go in emergency mode and switch off the three phase supply to safely operate the disc by hand.

The clamping function is active only if the previous operation was the unclamping.

Starting form FW rel. 2.88 it is possible to unclamp and clamp the turret in any condition.

## OPERATING FUNCTION N °7: SAFETY

The standard behaviour of the turret can be changed in order to allow the turret to work even if there are problems mainly on proximity switches.

**WARNING: all the functions are intended to be used only in case of effective problems. The improper use can cause a damage of the turret or the machine.**

Proceed as follows:

1. Clear all alarms (if present);
2. Set the operating function:

OPERATING FUNCTION N°7:	INPUTS		
	MODE01	MODE02	MODE03
SAFETY	1	1	1

3. Select the operation:

n°		PBIT01	PBIT02	PBIT04	PBIT08	PARITY
1	Execute the reference cycle (1)	1	0	0	0	1
2	Disable the management of unlocking switch: (the unlocking phase is based upon time instead that switch output) (2)	0	1	0	0	1
3	Disable the management of locking switch: (the locking phase is based upon time instead that switch output) (2)	1	1	0	0	0
4	Assume the actual position of the disc as position number 1 and disable the management of reference switch (3)	0	0	1	0	1
5	Apply a speed reduction of 30%	1	0	1	0	0
6	Disable the management of the thermal detector of the motor (4)	0	1	1	0	0
7	Toggle ON/OFF the output of the second digit of the last alarm. (5)	1	1	1	0	1
8	Toggle ON/OFF the serialize mode (6)	0	0	0	1	1
9	Toggle ON/OFF the output of the status of the switches (7)	1	0	0	1	0
10	Enable the autotest function (8)	0	1	0	1	0
15	Reset to standard functionality	1	1	1	1	0

4. Set the PSTART signal two times (with a pause of about 50ms. between the two pulses) without changing the code pattern to activate the function required.

**IMPORTANT:** there is no confirmation about the correct execution of the operation, because this is intended as a manual operation with effect that can be easily verified by operator.

All functionality set by this mode will be automatically reset at the power-off of the control unit.

- (1) This is an alternative way to execute the reference cycle in CNC in which the tool T 0 is not allowed. In this case only one PSTART is required.
- (2) In this case we assume that the turret is surely locked or unlocked in about 400 ms.
- (3) Be sure that the disc is really in position 1, otherwise this operation could be dangerous.  
This function can be performed only if the reference cycle has not yet been executed.
- (4) Please be sure that thermal detector is broken otherwise this could damage the servomotor.
- (5) The second digit of the alarm code is output on the ALBIT1..ALBIT4. A reset will turn-off this function.

(6) In this case a slow SSI - like protocol (Serial Synchronous Interface) is enabled using the ALBITs outputs.

SIGNAL	READY	CLOCK	DATA
OUTPUT	ALBIT1	ALBIT2	ALBIT4

The READY signal is independent and is ON if the turret is OK.  
If the turret is in alarm or in emergency, READY is OFF.

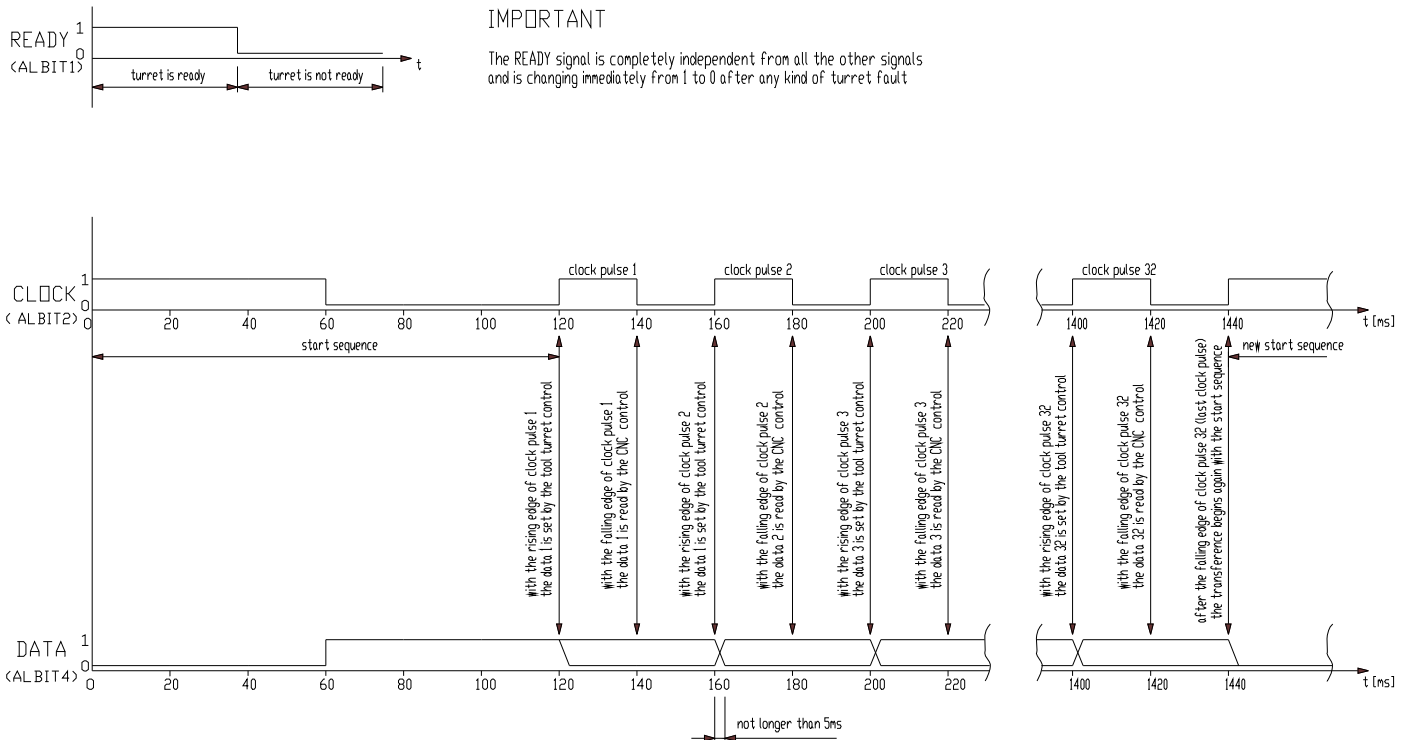

The data transmitted are: (MSB first, LSB last) in order:

Byte 1: FULL ALARM CODE (HEX eg. Alarm 35 -> 0011 0101)

Byte 2: Turret Position (0-> turret out of position; <0> turret is/can be locked on the position )

Byte 3: Digital inputs 1:

In order (ZEROSW,ULCKSW,LOCKSW, MOTVL,PTAB03,MOD03,MOD02,MOD01)

Byte 4: Digital inputs 2:

In order (PTAB02,PTAB01,PSTART,PARITY,PBIT08,PBIT04,PBIT02,PBIT01)

(7) The status of the switches of the turret is output as follows:

SIGNAL	MOTOVL (thermal detector)	ZEROSW (reference)	LOCKSW (locking)	ULCKSW (unlocking)
OUTPUT	INDEXD	ALBIT1	ALBIT2	ALBIT4

A reset will disable this function.

(8) Danger of collision to other parts of the lathe! Move the turret in a safe zone before starting the cycle. The autotest function is stopped and disabled by putting the turret in emergency mode (MODE 0).

## 4. DIAGNOSTIC

### ALARMS AND WARNINGS

The electronic unit constantly executes self-diagnosis and can signal alarms condition.

The alarms are represented as group and sub-group

The group alarm code is provided on output ALBIT1, ALBIT2, ALBIT4 according to the following table.

The sub-group alarm is available on ALPOSxx outputs.

Every group indentify a well defined source of problems.

ALARM CODE			ALARM N°	DESCRIPTION
ALBIT1	ALBIT2	ALBIT4		
1	0	0	1	Fault of supply.
0	1	0	2	Over voltage.
1	1	0	3	Over current/servo error/ thermal detector.
0	0	1	4	Unlocking faults, (switch fault, setting, pressure supply fault, etc.).
1	0	1	5	Locking faults, (switch fault, setting, pressure supply fault, etc.).
0	1	1	6	Zero search fault, (switch fault, setting, etc.).
1	1	1	7	Zero search missed/ Position code error/ Cycle time out/ PSTART signal time out.

Alarm are stored and can be reset with EMERGENCY/RESET function.

Power off causes the reset of the active alarm.

Please refer to the EXTENDED ALARM DESCRIPTION to get a more complete description of the alarm and to have information about troubleshooting.

A PC software is available to improve the stat-up procedure and troubleshooting.

#### Fault of electronic unit:

After recognizing the fault, the problem can be easily solved.

In case of electronic unit fault, it can be easily replaced.

## EXTENDED ALARM DESCRIPTION/TROUBLESHOOTING

In case an alarm is present on ALBITxx signals, the ALPOSxx signals give the sub-group code to better identify the cause of the problem.

The I/O board is provided by LED to give the status of each output.

ALARM	Description
1.0	Fault in resolver supply: -short on resolver line. If, after the short removal, the alarm persist, replace the controller.
1.1	Fault in three phase supply when the motor is enabled: - check the 230 V supply. If the voltage is OK and the alarm persist, replace the controller.
1.2,1.3, 1.4,1.6	Fault on internal auxiliary supply. If the alarm persist, replace the controller
1.5	Fault on internal 24 V supply to switches: -short on switches cable or defective switch. If the alarm persist, replace the controller
2.0	Overvoltage on three-phase line: -if random, ensure that three phase supply is under specification and in case provide additional stabilizers If the alarm persist, replace the controller
2.1	Overvoltage reached during dynamic braking: -the inertia loaded on disc is too high: try to reduce the inertia. If the alarm persist, replace the controller.
3.0	Motor Overcurrent. -short between servomotor wires -short between servomotor wire and ground -wrong resolver connection. -poor resolver cable shielding. To avoid thermal overload on power bridge due to repeated alarms, it is necessary to switch off the controller to clear the alarm.
3.1	Motor Overload. -inertia loaded on disc exceeds limits (check that the turret is set to the right inertia value by the PTAB03 signal - LK3 on connection box); -the unbalanced load exceeds limits; -crash during disc rotation; -zero switch or zero cam are not well positioned (if the alarm happen when the turret is locking at the reference cycle completion); -wiring to the motor or to the resolver is defective. -mechanical hardening
3.2	Position controller error exceeds limits: -inertia loaded on disc exceeds limits (check that the turret is set to the right inertia value by the PTAB03 signal - LK3 on connection box); -the unbalanced load exceeds limits; -the tool touch the piece slowly during disc rotation; -the wiring to the resolver is defective. -mechanical hardening
3.3	The time limit to execute the cycle has been reached: -the tool touch the piece slowly at the end of the cycle so cannot reach the final position;
3.4	The reference cam is out of the expected position (after the reference cycle have been performed) -reference switch is damaged or out of position -reference cam is damaged or out of position. -mechanical damage
3.5	The thermal detector of the motor : -indexing frequency too high; -defective motor; -the thermal detector is not connected. -wiring
3.6	Resolver fault. -wrong wiring -resolver excitation is off.
3.7	Ambient temperature on controller side too high.
3.8	Heatsink temperature too high.
3.11	General cycle timeout. A problem not covered by other alarms has occurred.
4.0	The signal of the locking switch stays on during the unlocking phase: -unlocking pressure too low; -bad position of locking switch; -bad switch connection/wiring (remote application mainly); -the locking switch is defective.

<b>ALARM</b>	<b>Description</b>
4.1	The signal of the unlocking switch stays off during the unlocking phase: -unlocking pressure too low; -bad position of unlocking switch; -bad switch connection/wiring (remote application mainly); -the unlocking switch is defective.
4.2	The signal of the unlocking switch goes off while the turret is unlocked: -problems of pressure; -bad switch connection/wiring (remote application mainly); -the unlocking switch is defective.
4.3	The signal of the locking switch goes on while the turret is unlocked: -problems of pressure; -bad switch connection/wiring (remote application mainly); -the locking switch is defective.
4.5	The two pressure inlet or the LOCKED and UNLOCKED switches are reversed. No pressure, the clamping mechanism does not move at all.
5.0	The signal of the unlocking switch stays on during the locking phase: -locking pressure too low (only hydraulic); -bad position of unlocking switch; -bad switch connection/wiring (remote application mainly); -the unlocking switch is defective.
5.1	The signal of the locking switch stays off during the locking phase: -locking pressure too low (only hydraulic); -bad position of locking switch; -bad switch connection/wiring (remote application mainly); -wrong control unit /software (card for a different size); -wrong reference cam regulation (turret lock over teeth); -the locking switch is defective.
5.2	The signal of the locking switch goes off while the turret is locked: -problems of pressure (only hydraulic); -bad switch connection/wiring (remote application mainly); -the locking switch is defective.
5.3	The signal of the unlocking switch goes on while the turret is locked: -problems of pressure (only hydraulic); -bad switch connection/wiring (remote application mainly); -the unlocking switch is defective.
5.5	The two pressure inlet or the LOCKED and UNLOCKED switches are reversed. No pressure at all.
6.0	Time-out in reference search: -the zero switch is defective (always off); -the position of the reference cam is wrong ; -bad switch connection/wiring (remote application mainly); -the disc cannot rotate.
6.1	Time-out in fine reference search: -the zero switch is defective (always on); -bad switch connection/wiring (remote application mainly); -the disc cannot rotate.
7.0	A tool is called before executing the zero cycle: -error in programming logic of CNC; -the operator did not call the reference cycle.
7.1	Parity Error in position code: -error in programming logic of CNC; -problems on wiring (PBIT** and PARITY) -slow outputs of CNC/PLC (the output value can be incorrect when the PSTART signal is given)
7.2	A tool non existing has been called: -error in CNC programming; -turret not correctly configured (check the number of positions set by PTAB01 and PTAB02 signals - LK1 and LK2 in connection box); -wiring problems.
7.3	A variation in position code has been detected but the PSTART signal is not arrived in within 5 seconds: (only FW before 2.6) -error in CNC programming; -wiring problems (PSTART signal not connected).
7.4	The time limit of continuous rotation of disc has been reached: -the turret has been activate in maintenance mode or service for long time; -the indexing frequency is too high.
7.8 or 7.7	The configuration input signals PTAB01 and PTAB02 are not configured (number of positions): -error in PTAB01 and PTAB02 setting (LK1 and LK2 in connection box);
7.11, 7.12, 7.13, 7.14, 7.15	One of the Internal memory tests failed. If the alarm persist after a switch-off/switch on, replace the controller.

**Note:** the code number is memorised by the control unit and can be read with a Diplomatic diagnostic software installed on a PC with the RS232 interface.

## 5. SCHEMATICS AND DRAWINGS

### DESCRIPTION OF DDC4 ELECTRICAL CONNECTIONS

#### POWER CONNECTIONS



PIN	CN10/X6	CN11/X7
1	L1	W
2	L2	V
3	L3	U
4		GND

TE: FASTON 6,3 mm Signal heart  
 PE: FASTON 6,3 mm Protection heart.

CN10: 3 pin Phoenix Power Combicon 7.68 male (three-phase AC supply)  
 – Cable-side connector provided in 'remote' configuration.  
 CN11: 4 pin Phoenix Power Combicon 7.68 (Servomotor power cable) –  
 Cable-side connector provided in 'remote' configuration.

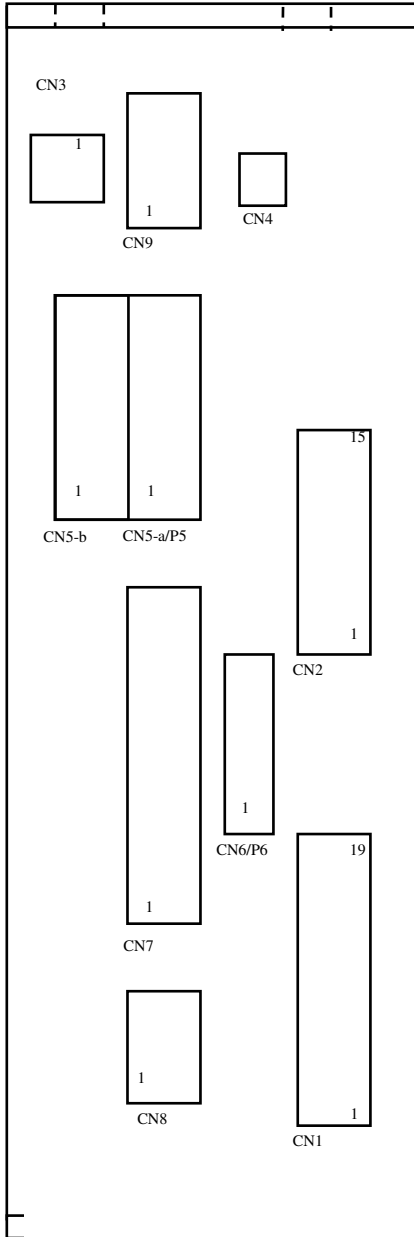
**SIGNAL CONNECTIONS**

PIN	CN1	CN2	CN7(1)
1	LOCKED	PBIT1	OUT 24V/UNRG
2	INDEXD	PBIT2	OUT 0V
3	ALBIT1	PBIT4	RES1_SIN+/RSIN
4	ALBIT2	PBIT8	RES1_SIN-/RSING
5	ALBIT4	PBIT16	GND_OUT (shield)
6	ALPOS1	PARITY	RES1_COS+/RCOS
7	ALPOS2	PSTART	RES1_COS-/RCOSG
8	ALPOS4	PTAB01	GND_OUT (shield)
9	ALPOS8	PTAB02	RES2_SIN- (not yet available)
10	ALPOS16	PTAB03	SSI_CLK+ (not yet available)
11	SPAREOUT1	MODE01	RES2_COS- (not yet available)
12	SPAREOUT2	MODE02	SSI_CLK- (not yet available)
13	EVLOCK	MODE03	MOTVL
14	EVLOCK	SPDSEL	LOCKSW
15	EVLOCK	SPAREIN1	SSI_DATA+ (not yet available)
16	EVLOCK	SPAREIN2	ULCKSW
17	EVULCK		RES1_EXC+/RPOW
18	EVULCK		RES1_EXC-/RPOWG
19	EVULCK		RES2_SIN+ (not yet available)
20	EVULCK		INPUT2
21			RES2_COS+ (not yet available)
22			INPUT3
23			SSI_DATA- (not yet available)
24			GND_OUT (shield)
25			ZEROSW

PIN	CN6/P6(1)	CN5-a/P5(1)	CN5-b(1)	CN9
1	RES1_EXC+/RPOW	OUT 24V/UNRG	OUT 24V/UNRG	RESERVED
2	RES1_EXC-/RPOWG	ZEROSW	MOTVL	RXD
3	RES1_SIN+/RSIN	OUT 0V	OUT 0V	TXD
4	RES1_SIN-/RSING	OUT 24V/UNRG	OUT 24V/UNRG	NC
5	RES1_COS+/RCOS	LOCKSW	INPUT2	GND
6	RES1_COS-/RCOSG	OUT 0V	OUT 0V	NC
7	MOTVL	OUT 24V/UNRG	OUT 24V/UNRG	RTS (2)
8	OUT 24V/UNRG	ULCKSW	INPUT3	CTS (2)
9		OUT 0V	OUT 0V	RESERVED

PIN	CN3	CN4	CN8
1	24VDC I/O	Analog Input (not yet available)	24VDC AZ
2	0VDC I/O	Analog reference	0VDC AZ

- (1) CN6, CN5-a must be used when the control unit is inside the turret. CN7 can be used when the control unit is placed inside the electrical cabinet.
- (2) Not necessary for direct PC connection

(UPPER SIDE VIEW)

- CN1: 20 pin/2 rows IDC connector male (Digital outputs) – cable-side connector not supplied  
 CN2: 16 pin/2 rows IDC connector male (Digital inputs) – cable-side connector not supplied  
 CN3: 2 pin Phoenix Contact Mini Combicon male (24V DC supply for I/O section) – cable-side connector supplied in remote version  
 CN4: 2 pin AMP MODU 2 (analog input): cable side not supplied in remote version.  
 CN5-a: 9 pin Phoenix Contact Micro Combicon (Switches connection inside the turret) – cable-side connector supplied  
 CN5-b: 9 pin Phoenix Contact Micro Combicon (two additional switches inside the turret) – cable-side connector not supplied  
 CN6: 8 pin HE14 Contek-Comatel male (resolver connection inside the turret) – cable-side connector not supplied  
 CN7: SUB-D 25 male (all signals from the turret) – cable-side connector not supplied  
 CN8: 3 pin Phoenix Contact Mini Combicon male (24V DC supply for driver section) – cable-side connector not supplied

## LED POSTION AND MEANINGS

**On the front side of DDC4 controller**, there is a small window in the cover. Looking through this window it is possible to see three green LEDs (on the farther side of the PCB board).

- The upper one must be ON and indicates that the main board is alive (24V DC supply voltage on CN8 is present).
- The middle one must be ON and indicates that the communication between I/O board and main board is present.
- The lower one must be OFF. It indicates a trouble on power section (shorts, ground fault, overcurrent..) this will show alarm 3.0 on alarm bits.

**On the right side of DDC4 controller**, there are several LEDs

Looking through the biggest hole, it is possible to see two green LEDs under the botton-shaped component in position IOLD1 and IOLD2. IOLD2 must be ON when the 24V DC supply is present on CN8.

Digital outputs have a RED LED, digital inputs have a GREEN LED.

This allow to have an immediate diagnosis and wiring check.

All information are binary-coded.

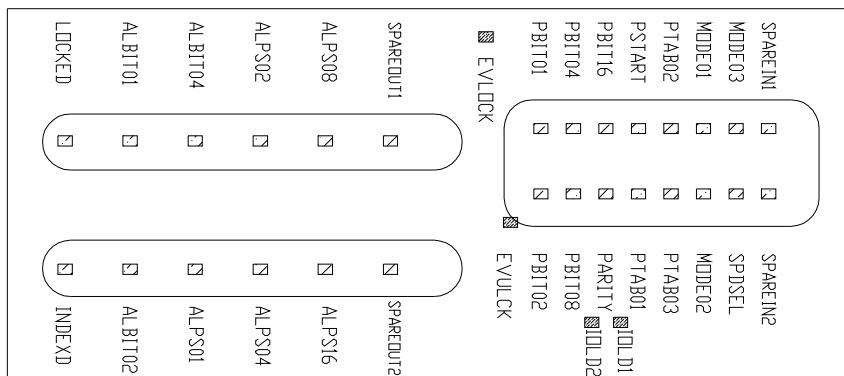

ALBIT4	ALBIT2	ALBIT1	ALARM N°
0	0	0	No alarm
0	0	1	1
0	1	0	2
0	1	1	3
1	0	0	4
1	0	1	5
1	1	0	6
1	1	1	7

ALPS16	ALPS08	ALPS04	ALPS02	ALPS01	Alarm sub-group	Actual position
0	0	0	0	0	0	Out of position
0	0	0	0	1	1	1
0	0	0	1	0	2	2
0	0	0	1	1	3	3
0	0	1	0	0	4	4
0	0	1	0	1	5	5
0	0	1	1	0	6	6
0	0	1	1	1	7	7
0	1	0	0	0	8	8
0	1	0	0	1	9	9
0	1	0	1	0	10	10
0	1	0	1	1	11	11
0	1	1	0	0	12	12
0	1	1	0	1	13	13
0	1	1	1	0	14	14
0	1	1	1	1	15	15
1	0	0	0	0		16
1	0	0	0	1		17
1	0	0	1	0		18
1	0	0	1	1		19
1	0	1	0	0		20
1	0	1	0	1		21
1	0	1	1	0		22
1	0	1	1	1		23
1	1	0	0	0		24

**FITTING INTO THE ELECTRICAL CABINET**

**OVERALL DIMENSIONS**

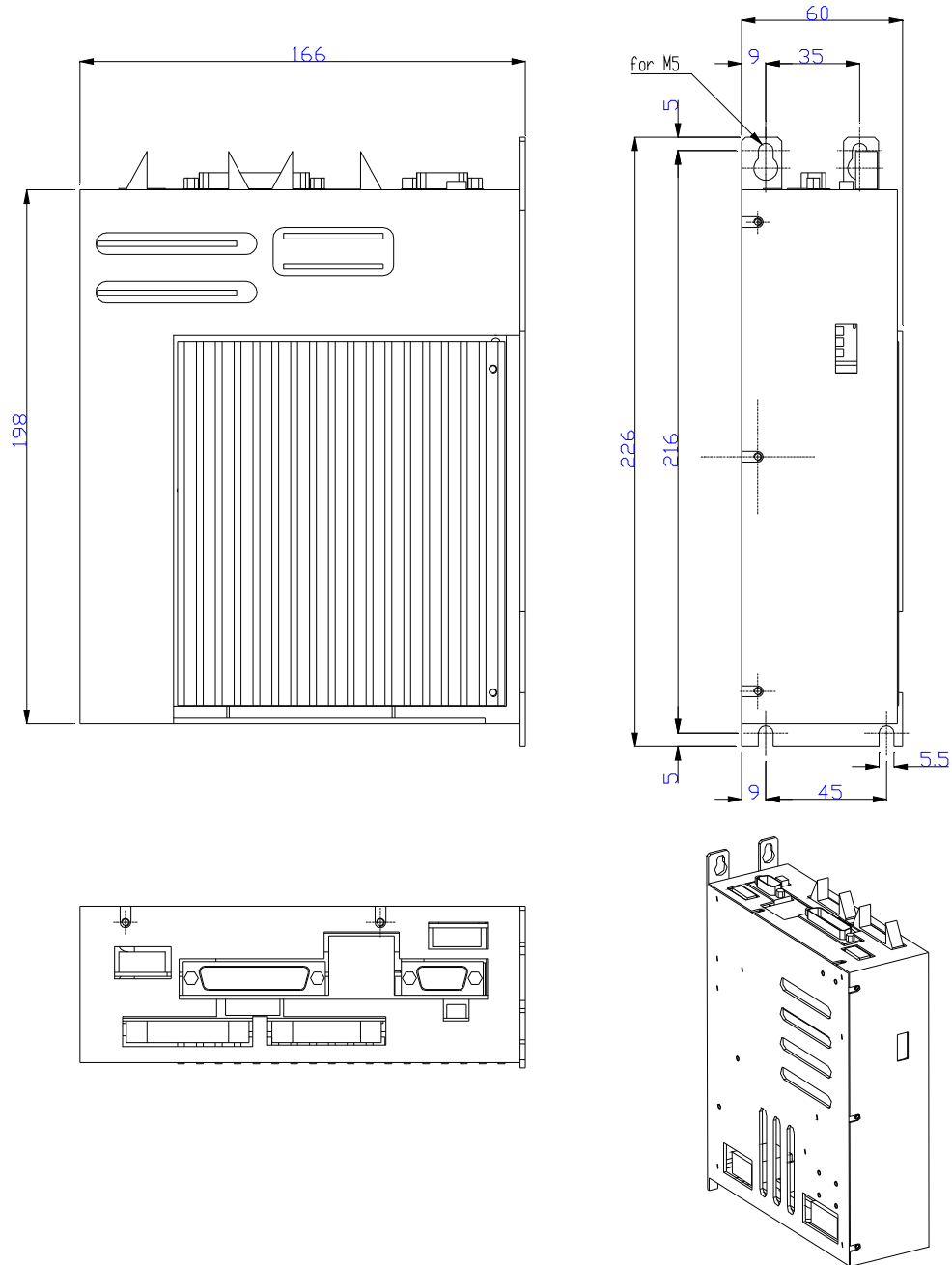

REMARKS: foresee at least 20 mm of free space on both sides and at least 100 mm above and below to allow connections and cooling airflow.

**GENERAL DRAWING FOR FITTING INTO THE ELECTRICAL CABINET**

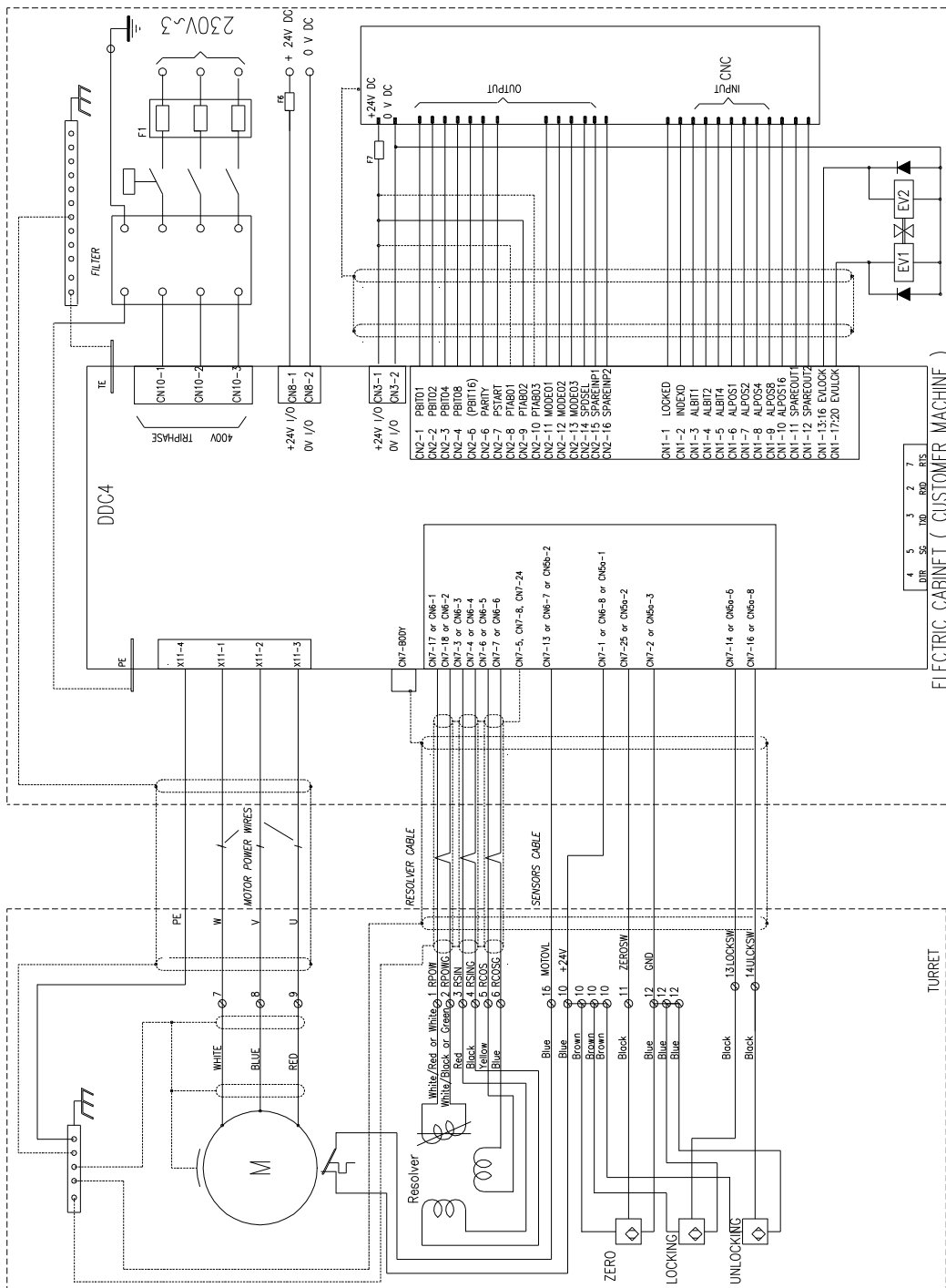

Note: for turrets with MDT driver tool system, the locking/unlocking switch wiring can be different. Please refer to the relevant MDT Instruction Manual.

**GENERAL DRAWING FOR FITTING INTO THE ELECTRICAL CABINET (TURRET WITH CONNECTORS)**

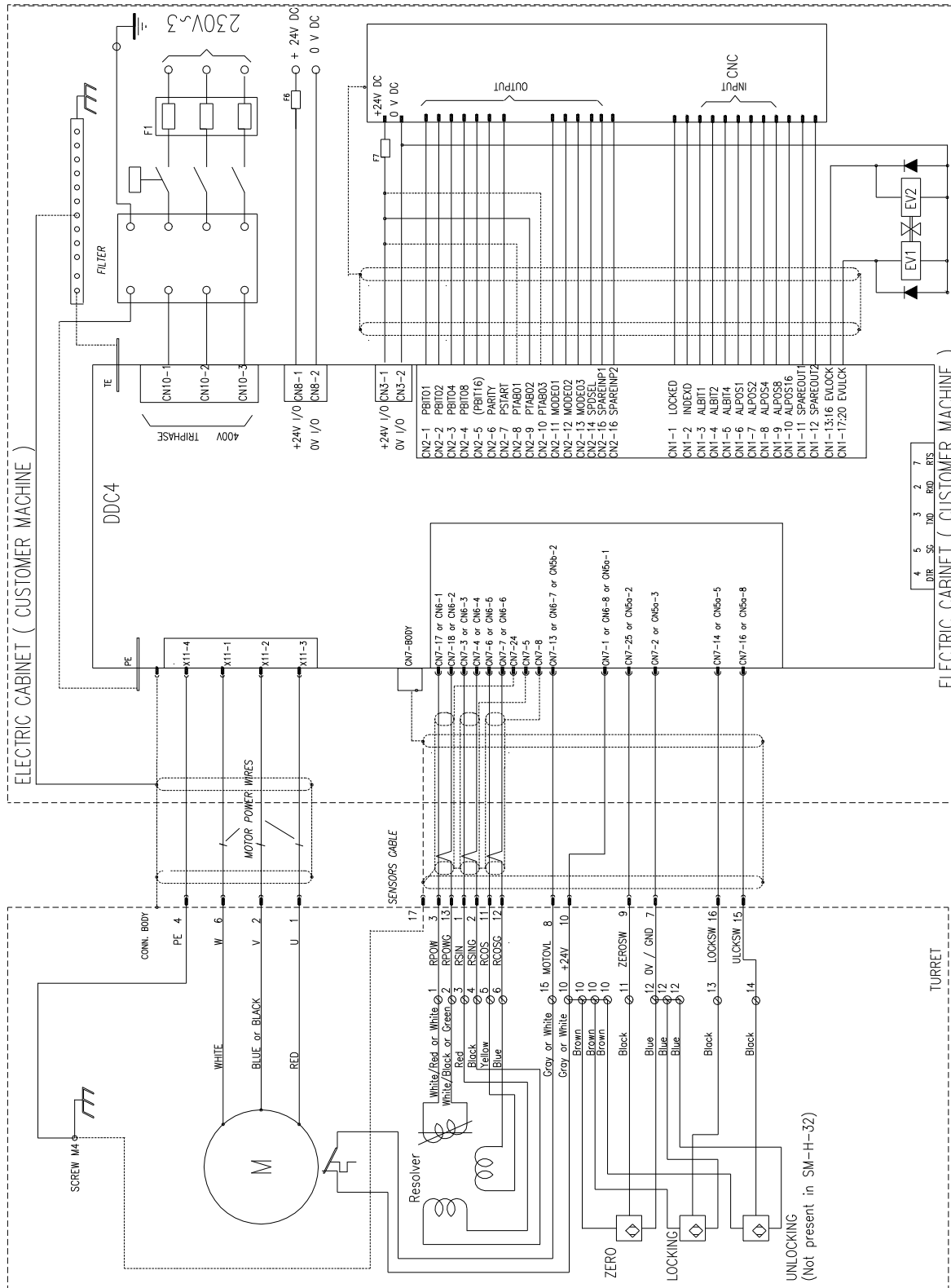

**SERVOMOTOR CABLE FOR FITTING INTO THE ELECTRICAL CABINET**

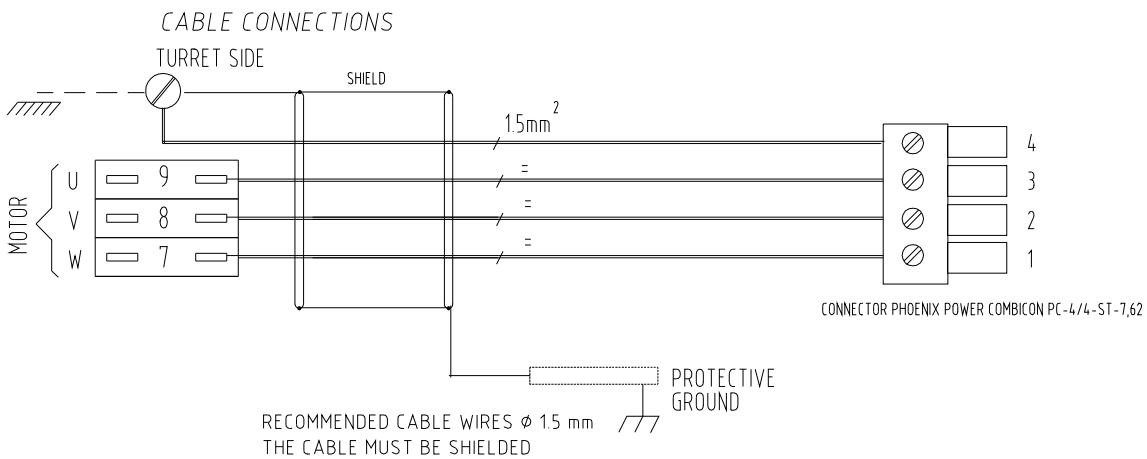
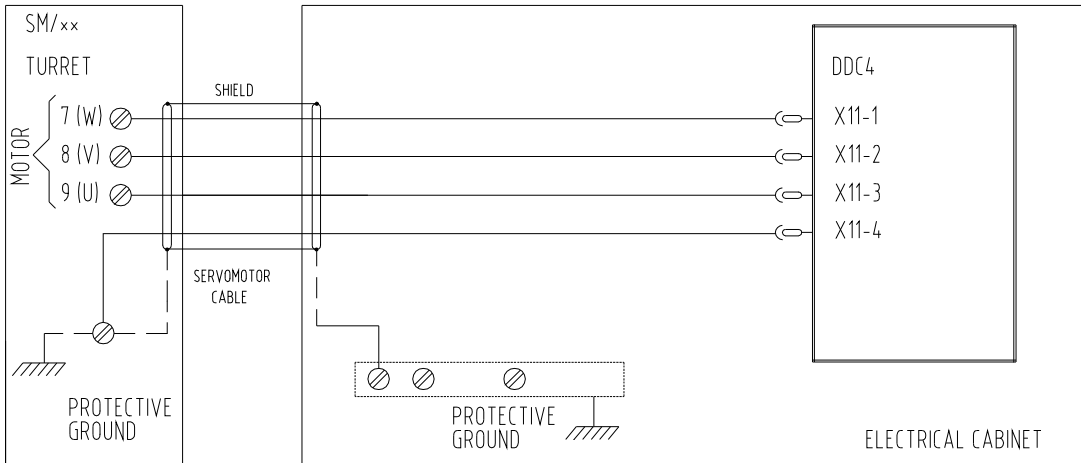

	<b>CAUTION</b>
	THE SYSTEM MUST ALWAYS BE DISCONNECTED FROM THE POWER SUPPLY IF ANY WORK IS CARRIED OUT!

**SERVOMOTOR CABLE (TURRET WITH CONNECTORS)**

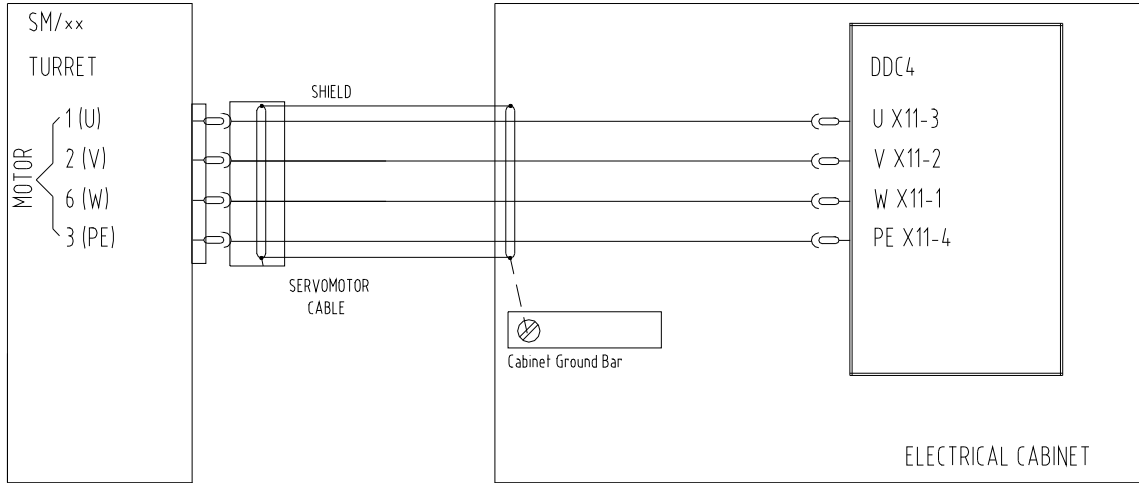

*CABLE CONNECTIONS*  
TURRET SIDE

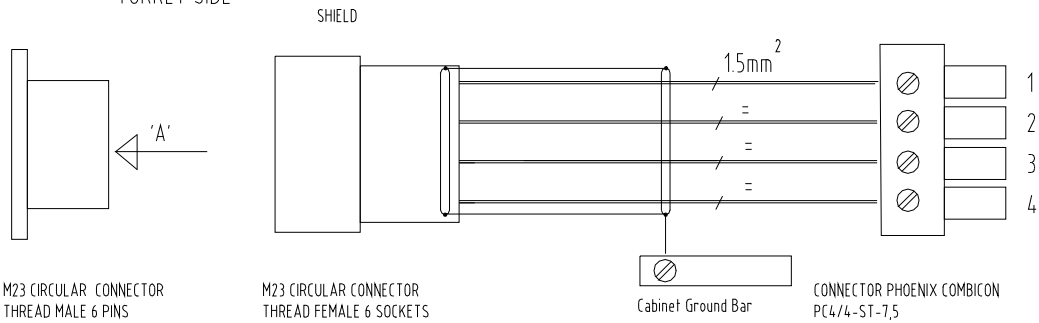

M23 CIRCULAR CONNECTOR  
THREAD MALE 6 PINS

M23 CIRCULAR CONNECTOR  
THREAD FEMALE 6 SOCKETS

Cabinet Ground Bar

CONNECTOR PHOENIX COMBICON  
PC4/4-ST-7,5

RECOMMENDED CABLE WIRES  $\phi$  1.5 mm  
THE CABLE MUST BE SHIELDED

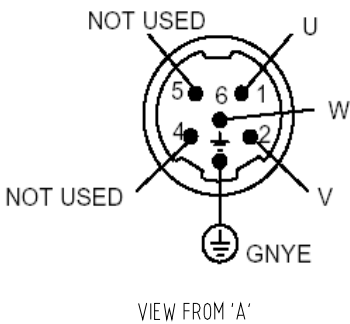

VIEW FROM 'A'

	<b>CAUTION</b>
	THE SYSTEM MUST ALWAYS BE DISCONNECTED FROM THE POWER SUPPLY IF ANY WORK IS CARRIED OUT!

**RESOLVER/SWITCHES CABLE FOR FITTING INTO THE ELECTRICAL CABINET.**

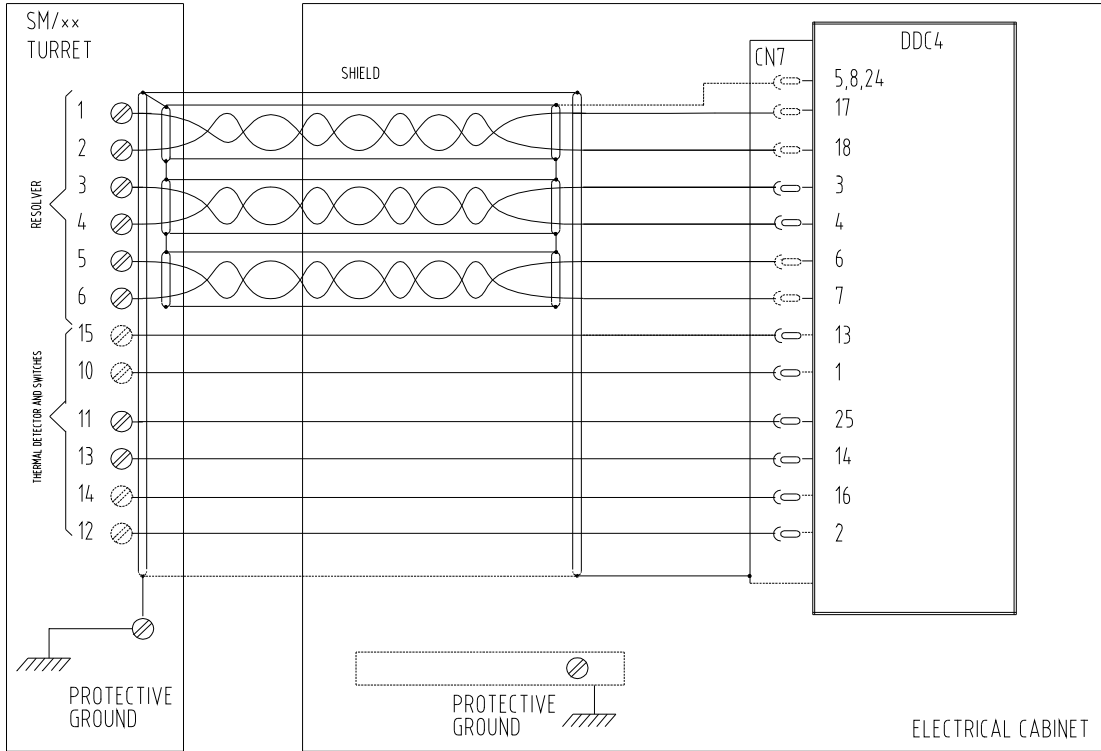

**NOTES FOR THE INSTALLATION**

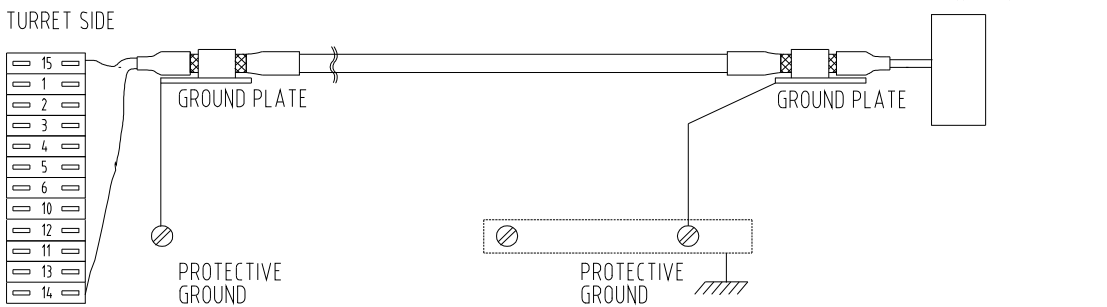

**SUGGESTED CABLE**  
 RESOLVER: N° 3 TWISTED AND SHIELDED PAIR 26 AWG (0,14mm2) min.  
 REST OF CABLE EXTERNAL SHIELDED.

THE DRAWING SHOWS HOW THE CABLE MUST BE CONNECTED TO THE GROUND PLATE.

	<b>CAUTION</b>
	THE SYSTEM MUST ALWAYS BE DISCONNECTED FROM THE POWER SUPPLY IF ANY WORK IS CARRIED OUT!

**RESOLVER/SWITCHES CABLE (TURRET WITH CONNECTORS).**

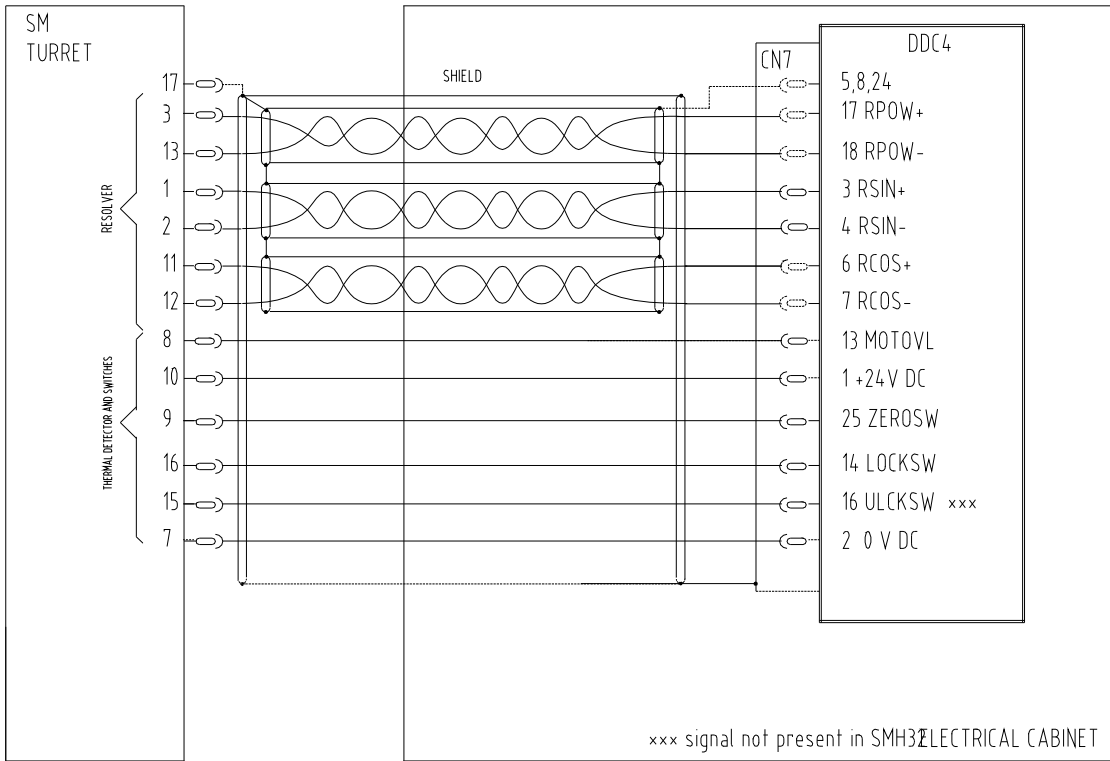

**NOTES FOR THE INSTALLATION**

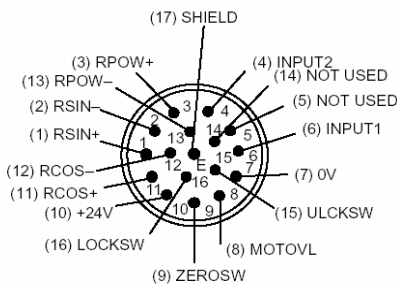
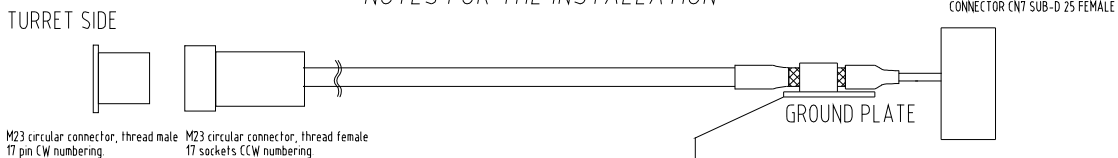

**SUGGESTED CABLE**  
 RESOLVER: N° 3 TWISTED AND SHIELDED PAIR 26 AWG (0,14mm2) min.  
 REST OF CABLE EXTERNAL SHIELDED.

**CAUTION**  
 THE SYSTEM MUST ALWAYS BE DISCONNECTED FROM THE POWER SUPPLY IF ANY WORK IS CARRIED OUT!

**DRIVER SUPPLY FOR FITTING INTO THE ELECTRICAL CABINET**

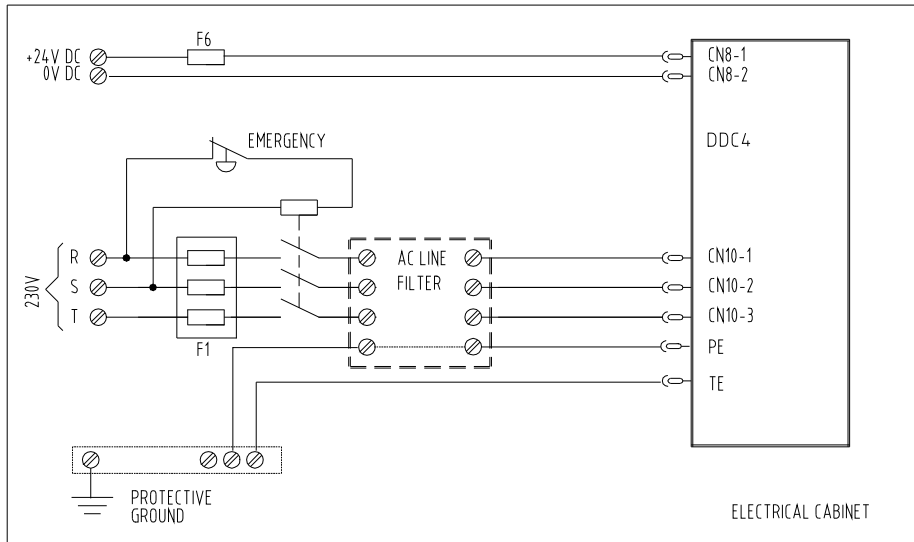

NOTES FOR THE INSTALLATION

CABINET SIDE

TE,PE FASTON 6,3 mm FEMALE

CN8 2 poles Phoenix Mini Combicon 3.5 mm  
FK-MCP 1,5/2-STF-3,5

CN10 3 Poles Phoenix Power Combicon  
PC-4/3-ST-7,62

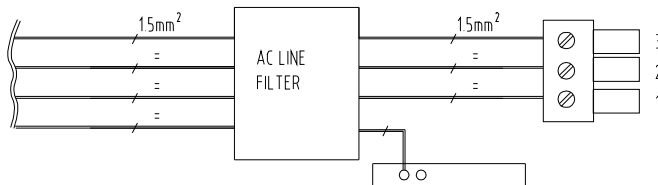

AC LINE FILTER	
VOLTAGE :	400VAC ± 10% 50/60Hz
CURRENT :	6A RMS
REQUIRED FOR E.M.C. COMPLIANCE	
ASK FOR DETAILED INFORMATIONS	

WIRES
RECOMMENDED WIRE SECTION 15 mm <sup>2</sup>
THE CABLE MUST BE SHIELDED
TO AVOID E.M.C. PROBLEMS

	<b>CAUTION</b>
	THE SYSTEM MUST ALWAYS BE DISCONNECTED FROM THE POWER SUPPLY IF ANY WORK IS CARRIED OUT!

**DIGITAL INPUT AND OUTPUT FOR FITTING INTO THE ELECTRICAL CABINET**

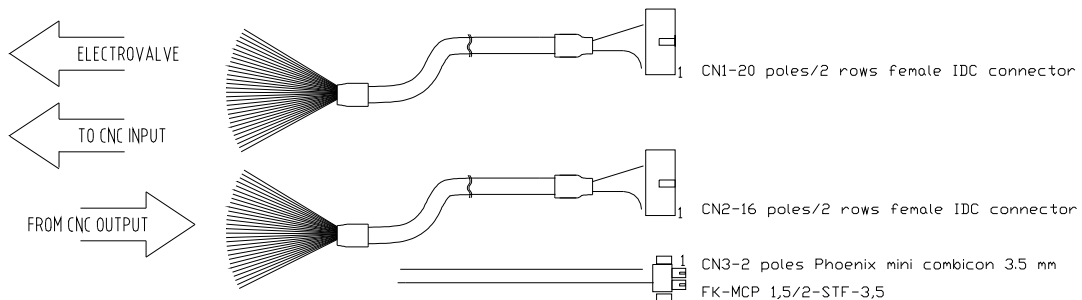
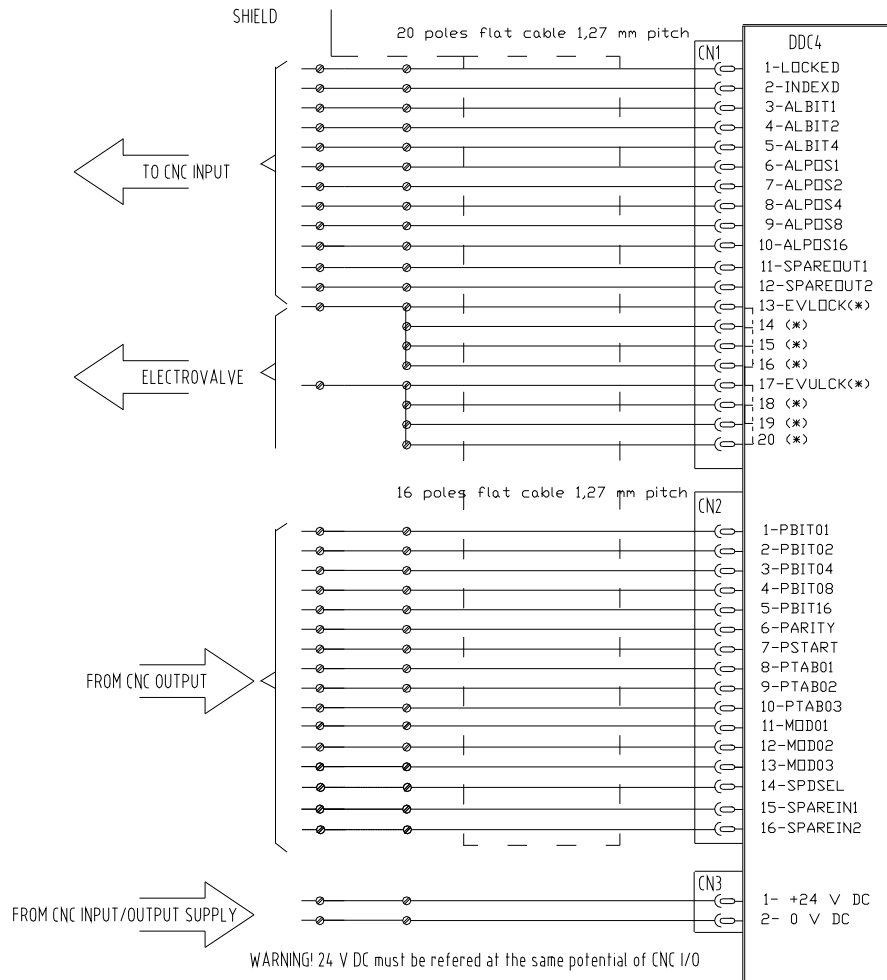

**SUGGESTED CABLE:**  
 USE SHIELDED CABLE IN CASE OF HARSH  
 E.M.C. ENVIRONMENT  
 KEEP FAR FROM POWER CABLES

**CAUTION**  
 THE SYSTEM MUST ALWAYS BE DISCONNECTED FROM THE  
 POWER SUPPLY IF ANY WORK IS CARRIED OUT!

## FITTING INTO THE TURRET

### CONNECTION BOX FOR FITTING INTO THE TURRET

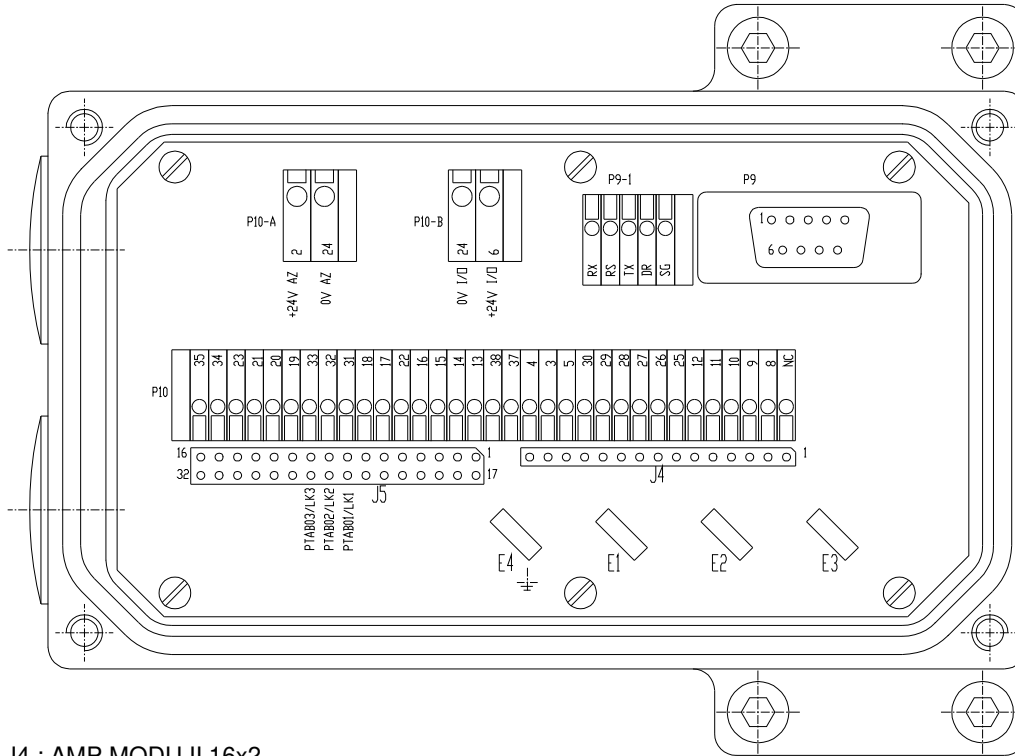

J4 : AMP MODU II 16x2  
 J5 : AMP MODU II 15x1  
 P10 : PHOENIX FFKDS/V-2,54  
 P10-A : PHOENIX FFKDS/V-3,5  
 P10-B : PHOENIX FFKDS/V-3,5  
 P9 : SUB-D 9 MALE  
 P9-1 : PHOENIX FFKDS/V-2,54  
 E1..E4 : FASTON 6,3 mm

I/O SUPPLY	Strip terminal / Spring terminal
+24V I/O	J5-17 to J5-32 / P10-6
0V I/O	J4-1 / P10-24

Driver 24V SUPPLY	Spring Terminal
+24V -AZ	2
0V Az	24

DIGITAL OUTPUT	Strip terminal / Spring terminal
LOCKED	J4-2 / P10-8
INDEXD	J4-3 / P10-9
ALBIT1	J4-4 / P10-10
ALBIT2	J4-5 / P10-11
ALBIT4	J4-6 / P10-12
ALPOS01	J4-7 / P10-25
ALPOS02	J4-8 / P10-26
ALPOS04	J4-9 / P10-27
ALPOS08	J4-10 / P10-28
ALPOS16	J4-11 / P10-29
AUXOUT1	J4-12 / P10-30
AUXOUT2	J4-13 / P10-5
EVLOCK	J4-14 / P10-3
EVULCK	J4-15 / P10-4

DIGITAL INPUT	Strip terminal / Spring terminal
PBIT01	J5-1 / P10-13
PBIT02	J5-2 / P10-14
PBIT04	J5-3 / P10-15
PBIT08	J5-4 / P10-16
PBIT16	J5-5 / P10-22
PARITY	J5-6 / P10-17
PSTART	J5-7 / P10-18
PTAB01/LK1	J5-8 / P10-31
PTAB02/LK2	J5-9 / P10-32
PTAB03/LK3	J5-10 / P10-33
MODE01	J5-11 / P10-19
MODE02	J5-12 / P10-20
MODE03	J5-13 / P10-21
SPDSEL	J5-14 / P10-23
AUXIN1	J5-15 / P10-34
AUXIN2	J5-16 / P10-35

RS232	Spring terminal	DB9
SG	SG	5
TXD	TX	2
RXD	RX	3
RTS	RS	4
DTR	DR	6
Reserved		1,9

Three Phase LINE	FASTON
L1	E1
L2	E2
L3	E3
EARTH-PE	E4

Notes: the numbering of the spring terminals is not progressive to keep the compatibility with the previous release.  
 The strip terminal allow to make pre-assembled cable easy to connect. The strip terminal allow to check the signals and can be used as a local keyboard by using 2,54 mm jumpers.

**CABLES FROM THE ELECTRICAL CABINET TO THE CONNECTION BOX**

INPUT/OUTPUT CABLE

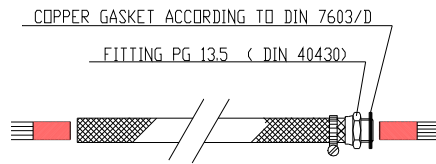

CABLE SECTION = 0,22 mm<sup>2</sup> min\*

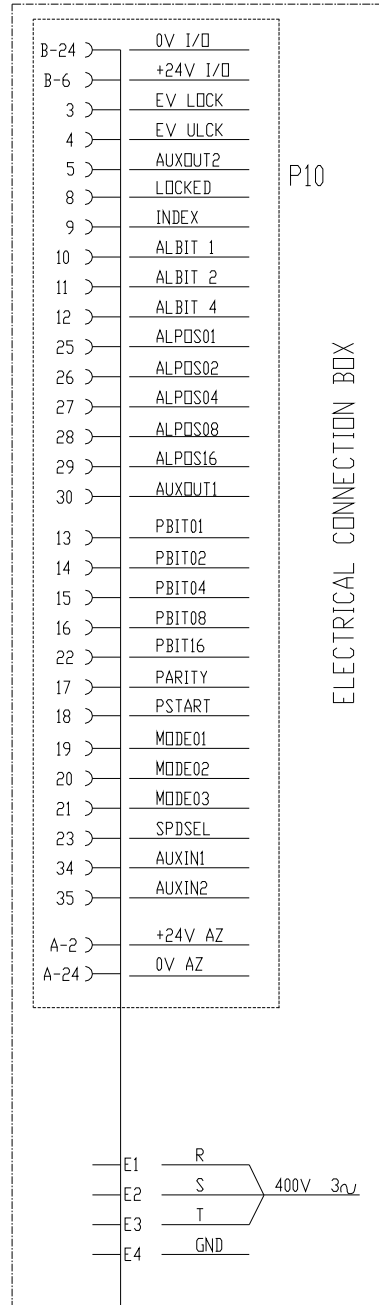
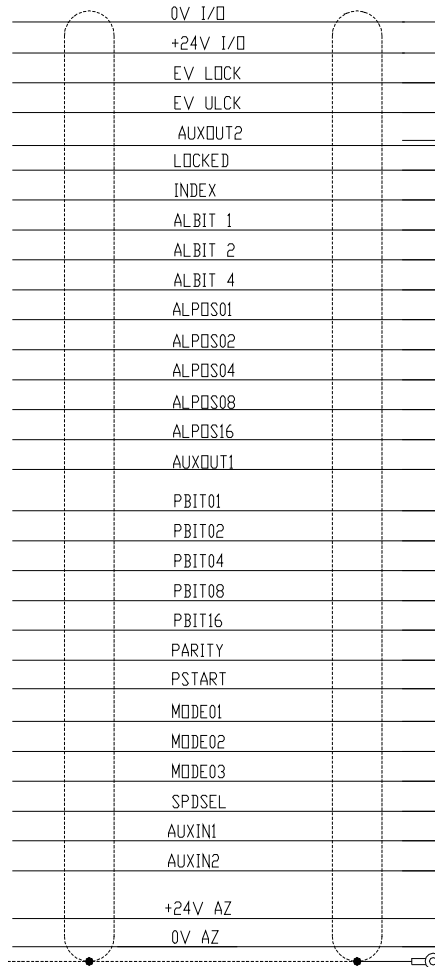

POWER CABLE

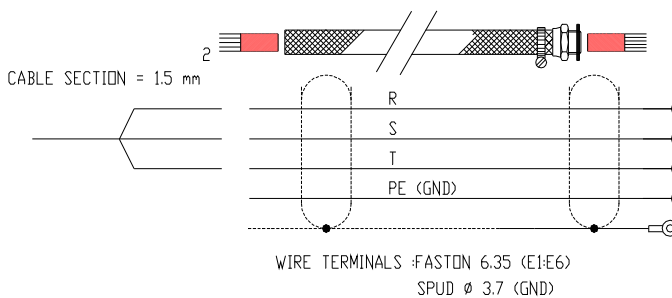



**TIME DIAGRAM**

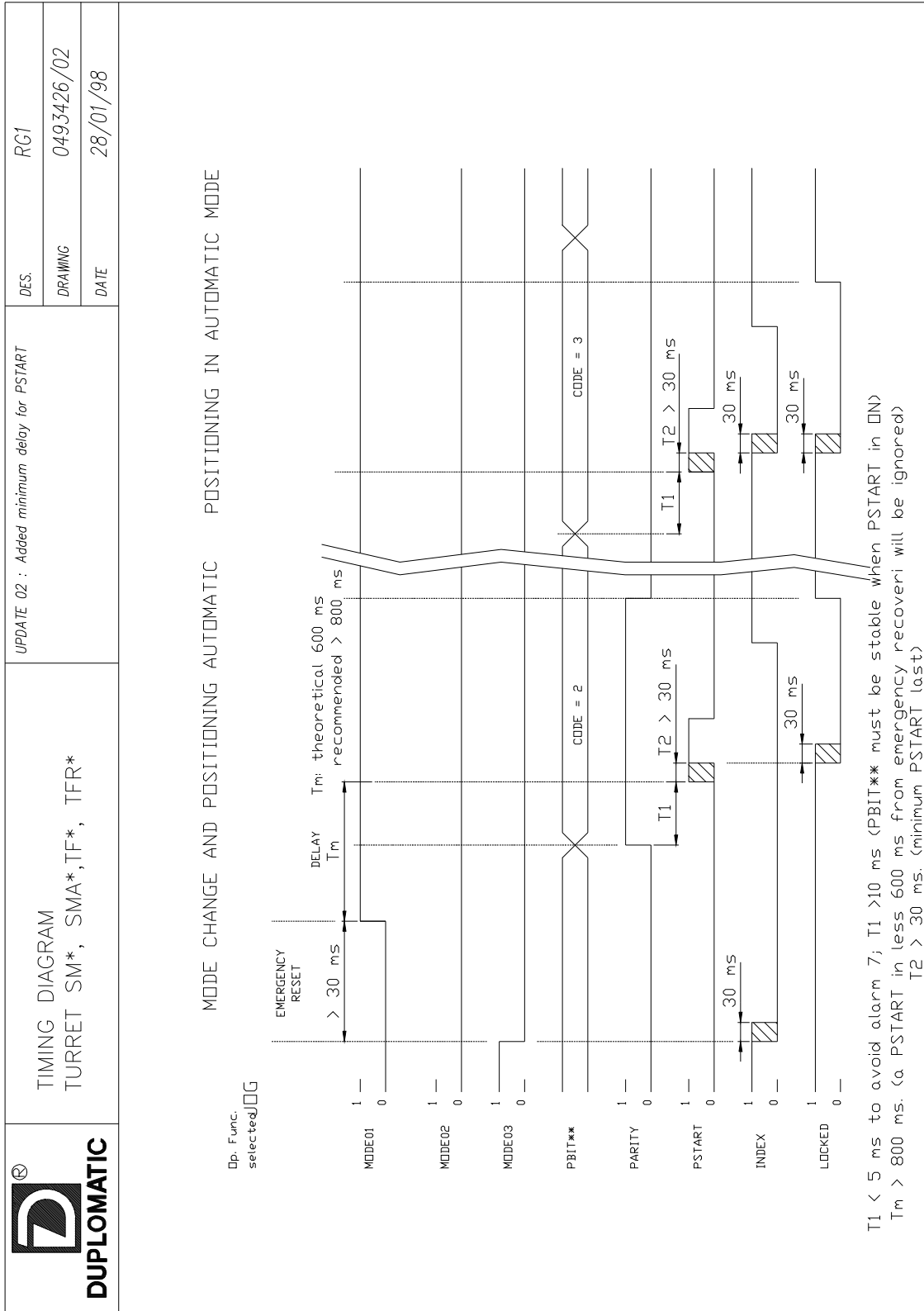

**SERVICE SERIAL CONNECTION**

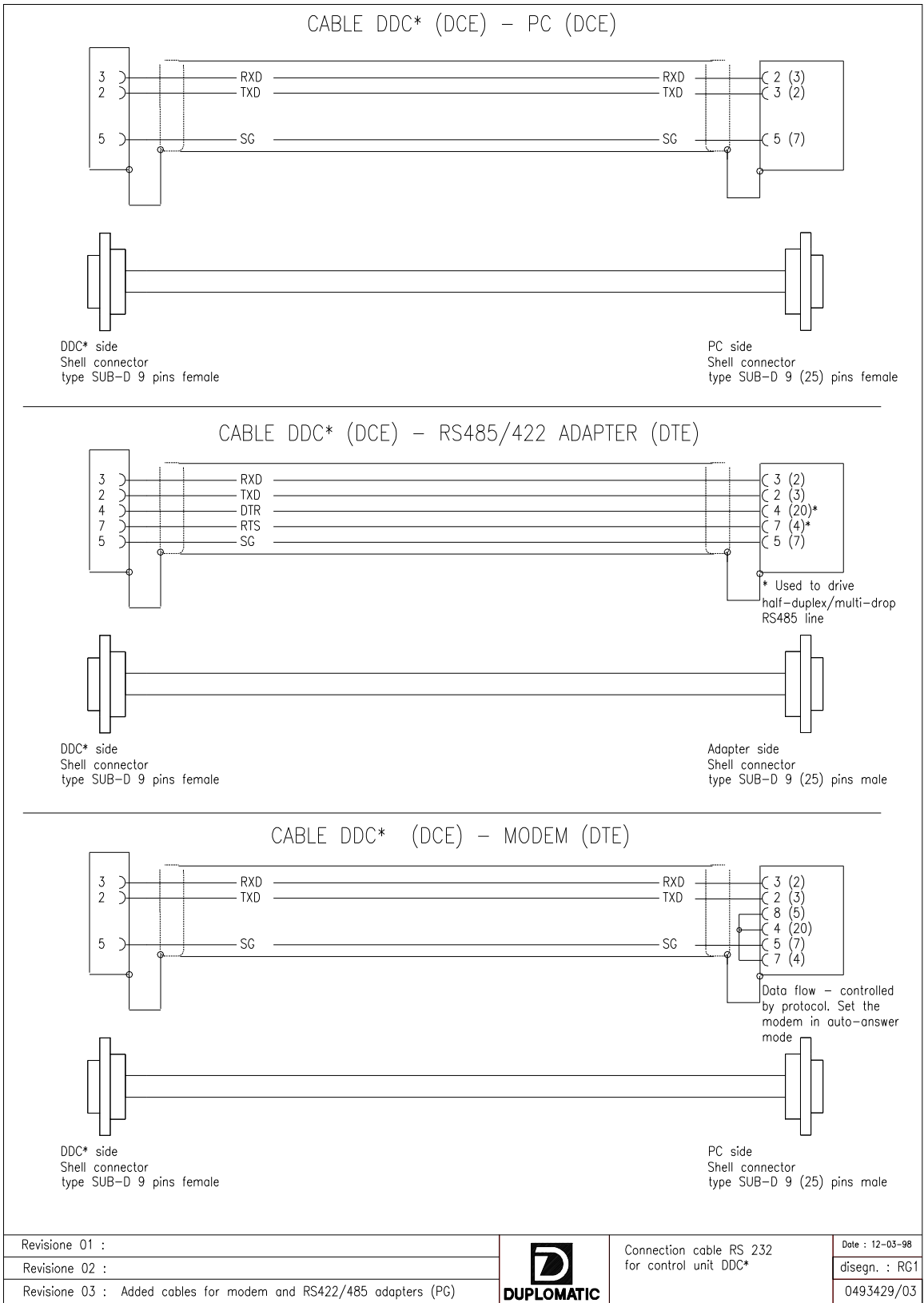

This page is left blank.

**DIPLOMATIC AUTOMATION S.r.l.**  
20025 LEGNANO (MI) - ITALY

P.LE BOZZI, 1  
TEL. 0331/472111  
FAX 0331/455161



e-mail: [info@diplomatic.it](mailto:info@diplomatic.it)

Come and visit Diplomatic homepage:  
[www.diplomaticautomation.com](http://www.diplomaticautomation.com)