

**COMPLETE OIL / AIR
COOLER SYSTEM
WITH AXIAL FAN FOR
INDUSTRIAL APPLICATIONS.**

Application

These high performance coolers with axial fans are suitable for hydraulic cooling applications with both return line and off line versions available. Typical applications include: industrial power units, lubrication systems (i.e. gearboxes) and machine tools.

OK-EL Product Features

Large Range Of Sizes
16 Bar Dynamic Pressure Rating
Modular Construction

EL coolers use high efficiency axial fans and strong cooling elements to achieve maximum performance. Many models are available with medium or high speed fans and the modular design allows the addition of circulation pumps and filters when required.

OKA & OKAF Product Features

Off-line Complete Package.
Avoids return line pressure & flow problems. Allows integration of quality Hydac filtration.

The OKA version with integrated oil circulation pump allows the cooler to create an off-line cooling system that can also provide high quality filtration if required with the OKAF model having the latest high performance Hydac filter also integrated.

The advantages of the off line cooling system include stable cooling (and filtration) performance irrespective of variations in flow and duty for the main hydraulic circuit. This allows the cooler to be sized to suit the heat load and not the maximum return line flow of the main circuit. A further advantage is that the off-line cooler is completely isolated from surge pressures in the return line that can potentially damage the cooler.

- Cooling range 2-108 kW at ΔT 40 °C
- Compact, efficient and powerful
- Standard motor flange B5/B14
- Simple disassembly of components

Oil/Air Cooler Units

Standard series EL Type



Test procedure certified following EN 1048

OIL/AIR COOLER

DESCRIPTION

GENERAL

In hydraulic systems energy is transformed and transmitted. During this transformation and transmission losses occur, i.e. mechanical and hydraulic energy is converted into heat. It is the function of the cooler to dissipate this heat.

ADVANTAGES OF THE OIL/AIR COOLERS:

- Environmentally friendly: exchange between air and oil not possible
- For commissioning only electrical energy is required
- Low operating costs, no additional cooling circuit necessary for the cooling medium, i.e. air

CONSTRUCTION FOR OK EL1-11

Oil/air cooler units consist of the (1) metal housing, (2) motor, (3) axial fan and (4) heat exchanger. The oil connections are external.

OK-EL1



OK-EL1

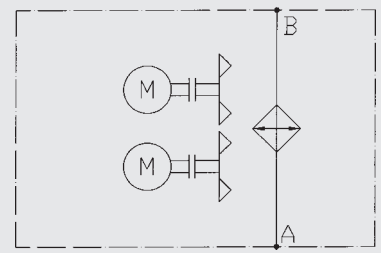

OK-EL2-3

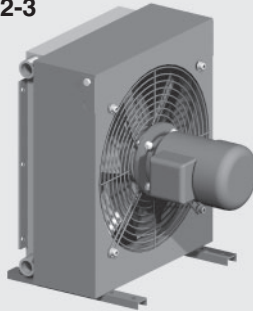

OK-EL2-3

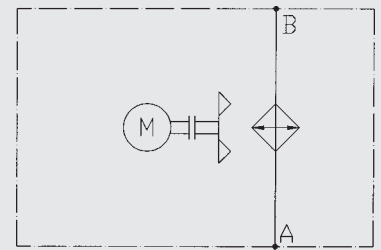

OK-EL7,8

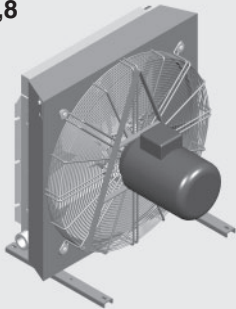

OK-EL4,5,6,9,10,11

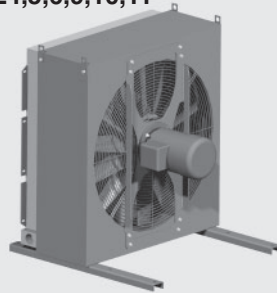

OK-EL4-11

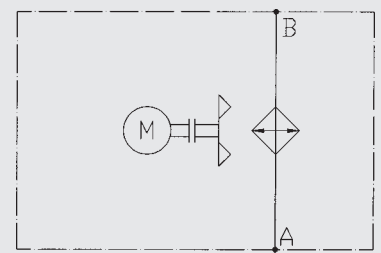

Example

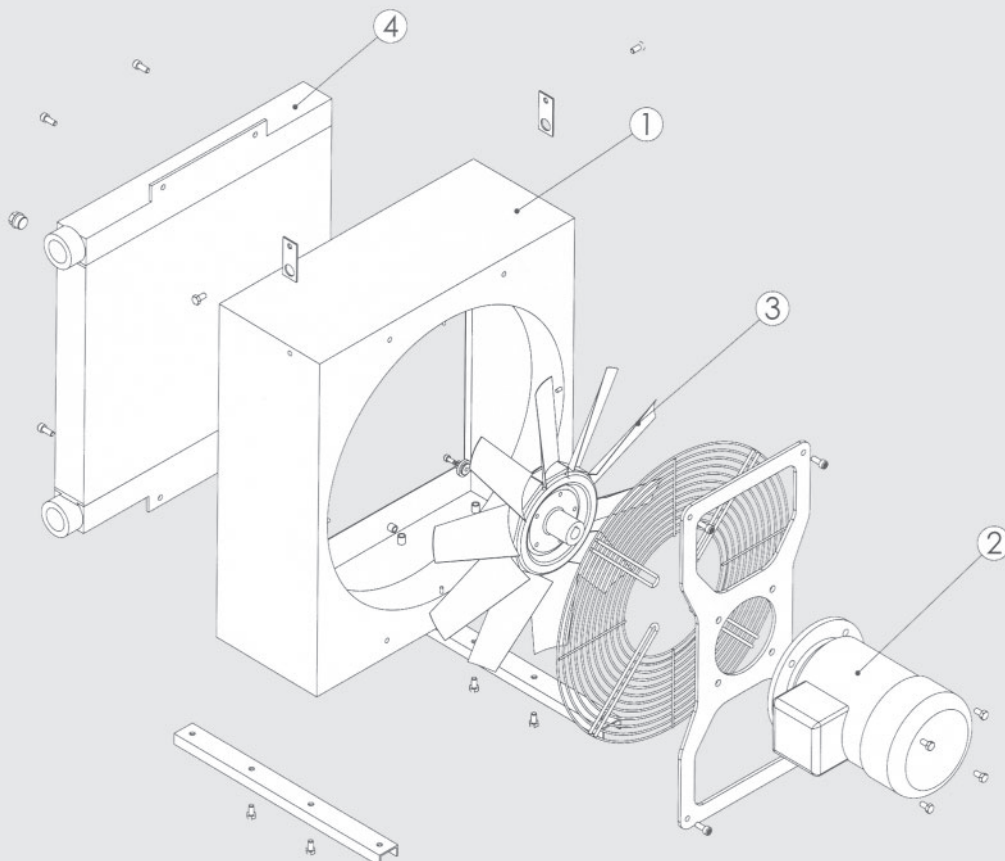

CONSTRUCTION FOR OKA & OKAF EL4-6

OKA-EL4,5,6

Oil/air cooler units consists of the metal housing (1), motor (2), axial fan (3) and heat exchanger (4), and low noise feed pump (5) with excellent suction performance. The oil connections are external.

OKA-EL4,5,6

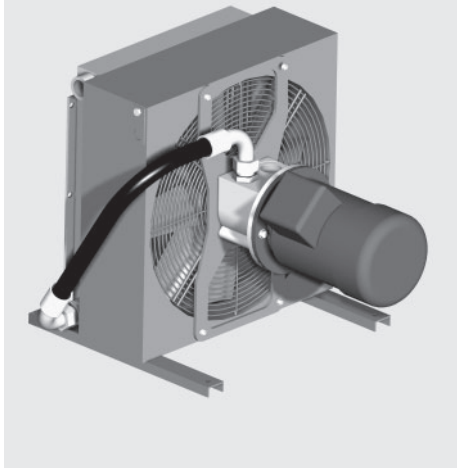

OKA-EL4,5,6

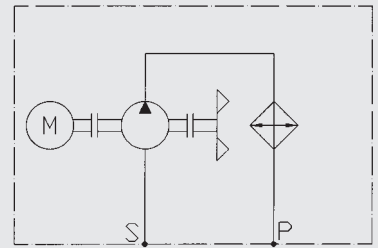

OKAF-EL4,5,6

Oil/air cooler units consist of the metal housing (1), motor (2), axial fan (3), heat exchanger (4), low noise feed pump (5) with excellent suction performance and filter (6). The oil connections are external, together with access to the filter element for cleaning and changing. The filters are fitted with visual clogging indicators, as standard.

OKAF-EL4,5,6

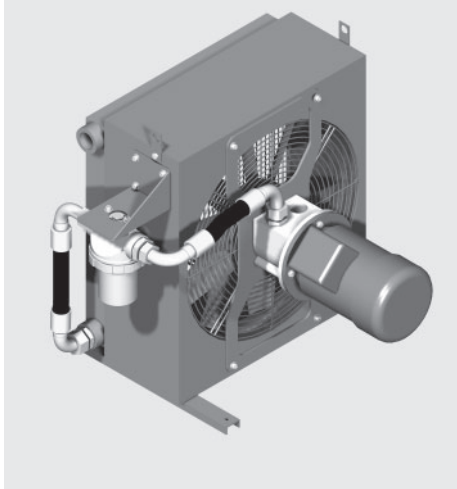

OKAF-EL4,5,6

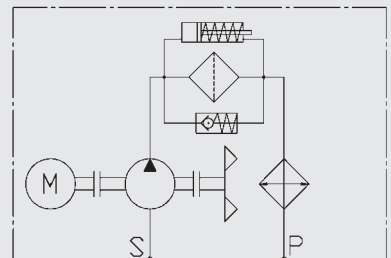

Example

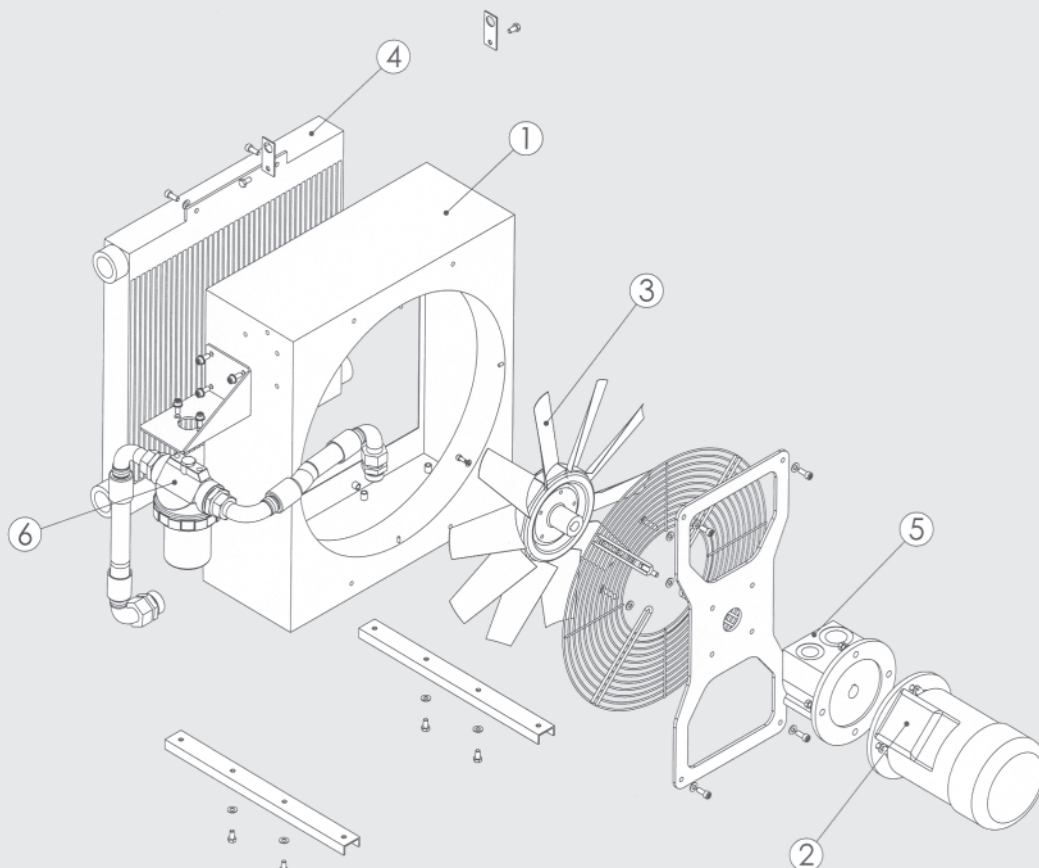

**CONSTRUCTION FOR
OKA & OKAF EL7-11**

OKA-EL7-11

Oil/air cooler units consist of the metal housing (1), motor (2), axial fan (3), heat exchanger (4), and low noise feed pump (5) with excellent suction performance. The oil connections are external.

OKA-EL7-11

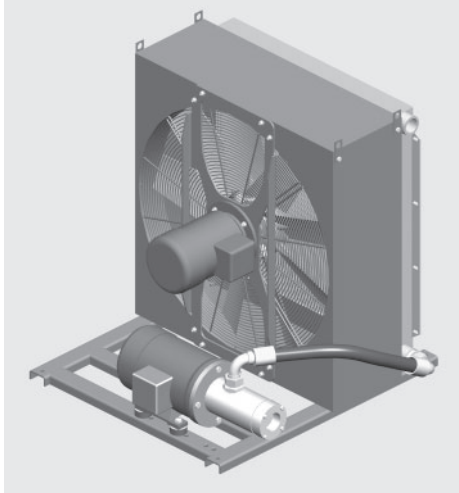

OKA-EL7-11

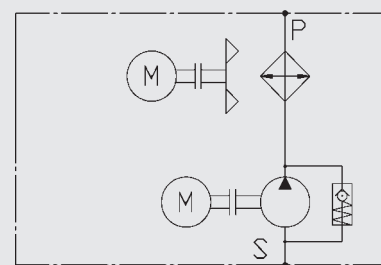

OKAF-EL7-11

Oil/air cooler units consist of the metal housing (1), motor (2), axial fan (3), heat exchanger (4), and low noise feed pump (5) with excellent suction performance and filter (6). The oil connections are external, together with access to the filter element for cleaning and changing. The filters are fitted with visual clogging indicators, as standard.

OKAF-EL7-11

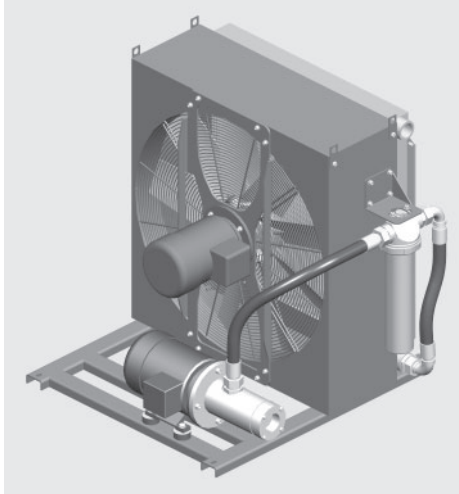

OKAF-EL7-11

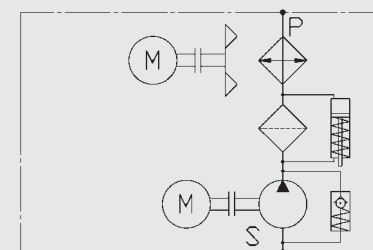

Example

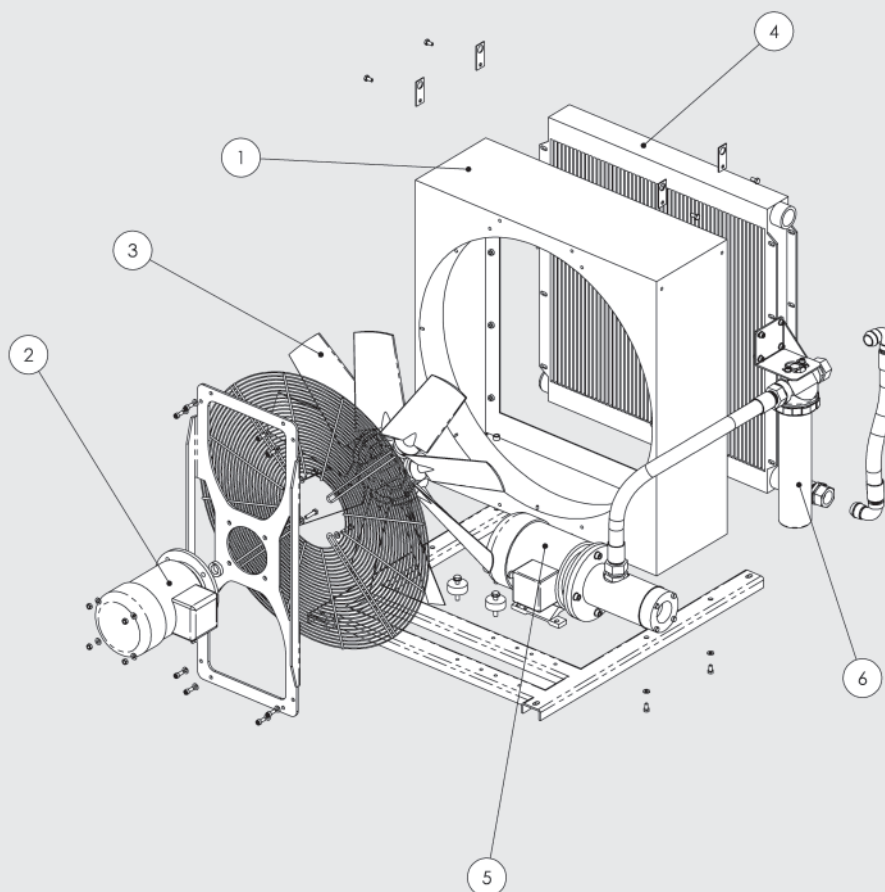

COOLER SELECTION

Designation:

P_v = Power loss [kW]

P_{01} = Specific cooling capacity [kW/°C]

V = Tank contents [l]

ρ_{oil} = Density of the oil [kg/l]
for mineral oil: 0.915 kg/l

C_{oil} = Specific heat capacity [kJ/kg°C]
for mineral oil 1.88 kJ/kg°C

ΔT = Temperature increase in the system [°C]

t = Operating time [min]

T_1 = Desired oil temperature [°C]

T_3 = Ambient temperature [°C]

Example 1:

Measurement of the power loss on existing units and machinery. For this method the temperature increase of the oil is measured over a certain period. The power loss can be calculated from the temperature increase.

Parameters:

The oil temperature increases from 20 °C to 45 °C over 15 minutes.

The tank contains 100 l.

Heat to be dissipated:

$$P_v = \frac{\Delta T \times c_{oil} \times \rho_{oil} \times V}{t \times 60} \quad [\text{kW}]$$

$$P_v = \frac{25 \times 1.88 \times 0.915 \times 100}{15 \times 60} = 4.78 \text{ [kW]}$$

Cooler selection:

– Desired oil temperature: 60 °C
– Ambient temperature (air): 30 °C

$$P_{01} = \frac{P_v}{T_1 - T_3} \quad [\text{kW/°C}]$$

$$P_{01} = \frac{4.78}{60 - 30} = 0.159 \quad [\text{kW/°C}]$$

A 10% safety margin is recommended to allow for element contamination, and therefore the specific power is:

$$P_{01} \times 1.1 = 0.175 \text{ kW/°C}$$

The power loss 0.175 kW/°C must be dissipated by an oil cooler.

Suggestion:

–Cooler OK-EL2H,

$$P_{01} = 0.18 \text{ kW/°C at 80 l/min.}$$

Example 2:

The power loss can also be estimated: With unrestricted flow approx. 15 to 20% of the drive power. With restricted flow up to 30% of the drive power.

1. TECHNICAL DETAILS

1.1. TABLE OF TECHNICAL SPECIFICATIONS FOR SIZES 1 TO 6

Type of cooler	Displacement [cm³/U]	Oil flow [l/min]	N° of poles [-] / size[-]	Motor capacity [kW] at 50 Hz	Noise level (1m distance) [dB(A)] at 50 Hz	Max. operating pressure [bar]	Max. oil temperature [°C]	Max. viscosity [mm²/s]	Size of filter [-]	Weight [kg]
OK-EL1H	–	*120	**	0.04	60	16	130	2000	–	7
OK-EL2S	–	*180	4/63	0.18	64	16	130	2000	–	13
OK-EL2H	–	*180	2/63	0.25	80	16	130	2000	–	13
OK-EL3S	–	*180	4/63	0.18	66	16	130	2000	–	17
OK-EL3H	–	*180	2/71	0.55	85	16	130	2000	–	17
OK-EL4L	–	*200	6/71	0.25	63	16	130	2000	–	31
OK-EL4S	–	*200	4/71	0.37	72	16	130	2000	–	31
OKA-EL4L	28-40	24/34	6/90	1.1	68	6	80	350	–	34
OKA-EL4S	28-40	36/52	4/90	1.8	75	6	80	350	–	34
OKAF-EL4L	28-40	24/34	6/90	1.1	68	6	80	350	LPF 160	41
OKAF-EL4S	28-40	36/52	4/90	1.8	75	6	80	350	LPF 160	41
OK-EL5L	–	*250	6/80	0.37	65	16	130	2000	–	38
OK-EL5S	–	*250	4/90	1.1	75	16	130	2000	–	38
OKA-EL5L	28-40	24/34	6/90	1.1	70	6	80	350	–	41
OKA-EL5S	28-40	36/52	4/90	1.8	80	6	80	350	–	41
OKAF-EL5L	28-40	24/34	6/90	1.1	70	6	80	350	LPF 160	48
OKAF-EL5S	28-40	36/52	4/90	1.8	80	6	80	350	LPF 160	48
OK-EL6L	–	*250	6/80	0.37	67	16	130	2000	–	43
OK-EL6S	–	*250	4/90	1.1	77	16	130	2000	–	47
OKA-EL6L	28-40	24/34	6/90	1.1	70	6	80	350	–	50
OKA-EL6S	28-40	36/52	4/90	1.8	81	6	80	350	–	50
OKAF-EL6L	28-40	24/34	6/90	1.1	70	6	80	350	LPF 160	57
OKAF-EL6S	28-40	36/52	4/90	1.8	81	6	80	350	LPF 160	57

* :max oil flow

** :electrical fans IP20

- Suction vacuum at pump inlet max -0.4 bar.
- For direction of fan rotation, see arrow on cooler housing.
- Electric vent drive: axial drive with forward flow through cooler element (sucking).
- Cooling fluid: mineral oil to DIN 51524; for other fluids, please contact our sales/technical department.
- Three-phase motors IP55, conforming to CE norm.
- The noise levels are only a guide as acoustic properties vary and depend on the characteristics of the room, connections, viscosity and resonance.

Warning!

When operating a cooler in situations where the difference in temperature between ambient air and inlet oil exceed 50 Deg. Celsius, care must be taken to avoid cycling of the fan at full speed/air flow as this can cause rapid change in material temperature of element and may result in significant reduction in lifetime or direct damage to the element through thermal stress.

Please contact your Hydac Branch or distributor for speed control solutions.

COOLER SELECTION

Designation:

P_v = Power loss [kW]

P_{01} = Specific cooling capacity [kW/°C]

V = Tank contents [l]

ρ_{oil} = Density of the oil [kg/l]
for mineral oil: 0.915 kg/l

C_{oil} = Specific heat capacity [kJ/kg°C]
for mineral oil 1.88 kJ/kg°C

ΔT = Temperature increase in the system [°C]

t = Operating time [min]

T_1 = Desired oil temperature [°C]

T_3 = Ambient temperature [°C]

Example 1:

Measurement of the power loss on existing units and machinery. For this method the temperature increase of the oil is measured over a certain period. The power loss can be calculated from the temperature increase.

Parameters:

The oil temperature increases from 20 °C to 60 °C over 16 minutes.

The tank contains 400 l.

Heat to be dissipated:

$$P_v = \frac{\Delta T \times c_{oil} \times \rho_{oil} \times V}{t \times 60} \quad [\text{kW}]$$

$$P_v = \frac{40 \times 1.88 \times 0.915 \times 400}{16 \times 60} = 28.7 \quad [\text{kW}]$$

Cooler selection:

- Desired oil temperature: 60 °C
- Ambient temperature (air): 30 °C

$$P_{01} = \frac{P_v}{T_1 - T_3} \quad [\text{kW/°C}]$$

$$P_{01} = \frac{28.7}{60 - 30} = 0.96 \quad [\text{kW/°C}]$$

A 10% safety margin is recommended to allow for element contamination, and therefore the specific power is:

$$P_{01} \times 1.1 = 1.06 \text{ kW/°C.}$$

The power loss 1.06 kW/°C must be dissipated by an oil cooler.

Suggestion:

-Cooler OK-EL8S,

$$P_{01} = 1.08 \text{ kW/°C at 90 l/min.}$$

Example 2:

The power loss can also be estimated: With unrestricted flow approx. 15 to 20% of the drive power. With restricted flow up to 30% of the drive power.

1.2. TABLE OF TECHNICAL SPECIFICATIONS FOR SIZES 7 TO 11

Type of cooler	Displacement [cm³/U]	Oil flow [l/min] at max. operating pressure	N° of poles [-] / size [-] for the fan motor	N° of poles [-] / size [-] for the pump motor	Motor capacity [kW] at 50 Hz for the fan motor	Motor capacity [kW] at 50 Hz for the pump motor	Noise level [dB(A)] (at 1m distance) at 50 Hz	Max. operating pressure [bar]	Max. oil temperature [°C]	Max. Viscosity [mm²/s] continuous working	Size of filter [-]	Weight [kg]
OK-EL7L	-	*300	6/90		1.1		76	16	130	2000	-	54
OK-EL7S	-	*300	4/100		3.0		84	16	130	2000	-	59
OKA-EL7L	40/58 69	100/150 180	6/90	2/90 2/112	1.1	3.0 5.5	76	6	80	320/130 240	-	74
OKA-EL7S	40/58 69	100/150 180	4/100	2/90 2/112	3.0	3.0 5.5	84	6	80	320/130 240	-	79
OKAF-EL7L	40/58 69	100/150 180	6/90	2/90 2/112	1.1	3.0 5.5	76	6	80	320/130 240	LPF 280	82
OKAF-EL7S	40/58 69	100/150 180	4/100	2/90 2/112	3.0	3.0 5.5	84	6	80	320/130 240	LPF 280	87
OK-EL8L	-	*300	6/90		1.1		77	16	130	2000	-	58
OK-EL8S	-	*300	4/100		3.0		84	16	130	2000	-	63
OKA-EL8L	40/58 69	100/150 180	6/90	2/90 2/112	1.1	3.0 5.5	77	6	80	320/130 240	-	78
OKA-EL8S	40/58 69	100/150 180	4/100	2/90 2/112	3.0	3.0 5.5	84	6	80	320/130 240	-	83
OKAF-EL8L	40/58 69	100/150 180	6/90	2/90 2/112	1.1	3.0 5.5	77	6	80	320/130 240	LPF 280	86
OKAF-EL8S	40/58 69	100/150 180	4/100	2/90 2/112	3.0	3.0 5.5	84	6	80	320/130 240	LPF 280	91
OK-EL9LL	-	*330	8/90		0.55		70	16	130	2000	-	109
OK-EL9L	-	*330	6/90		1.1		77	16	130	2000	-	109
OKA-EL9LL	40/58 69	100/150 180	8/90	2/90 2/112	0.55	3.0 5.5	70	6	80	320/130 240	-	133
OKA-EL9L	40/58 69	100/150 180	6/90	2/90 2/112	1.1	3.0 5.5	77	6	80	320/130 240	-	133
OKAF-EL9LL	40/58 69	100/150 180	8/90	2/90 2/112	0.55	3.0 5.5	70	6	80	320/130 240	LPF 280	141
OKAF-EL9L	40/58 69	100/150 180	6/90	2/90 2/112	1.1	3.0 5.5	77	6	80	320/130 240	LPF 280	141
OK-EL10LL	-	*330	8/100		1.1		72	16	130	2000	-	142
OK-EL10L	-	*330	6/112		2.2		80	16	130	2000	-	142
OKA-EL10LL	40/58 69	100/150 180	8/100	2/90 2/112	1.1	3.0 5.5	72	6	80	320/130 240	-	167
OKA-EL10L	40/58 69	100/150 180	6/112	2/90 2/112	2.2	3.0 5.5	80	6	80	320/130 240	-	167
OKAF-EL10LL	40/58 69	100/150 180	8/100	2/90 2/112	1.1	3.0 5.5	72	6	80	320/130 240	LPF 280	175
OKAF-EL10L	40/58 69	100/150 180	6/112	2/90 2/112	2.2	3.0 5.5	80	6	80	320/130 240	LPF 280	175
OK-EL11LL	-	*330	8/132		2.2		77	16	130	2000	-	190
OK-EL11L	-	*330	6/132		3.0		85	16	130	2000	-	190
OKA-EL11LL	40/58 69	100/150 180	8/132	2/90 2/112	2.2	3.0 5.5	77	6	80	320/130 240	-	216
OKA-EL11L	40/58 69	100/150 180	6/132	2/90 2/112	3.0	3.0 5.5	85	6	80	320/130 240	-	216
OKAF-EL11LL	40/58 69	100/150 180	8/132	2/90 2/112	2.2	3.0 5.5	77	6	80	320/130 240	LPF 280	224
OKAF-EL11L	40/58 69	100/150 180	6/132	2/90 2/112	3.0	3.0 5.5	85	6	80	320/130 240	LPF 280	224

* max oil flow

See notes below the table at page 5.

1.3. HYDRAULIC DETAILS

1.3.1 Cooling capacity:

depending on oil flow and the temperature differential ΔT between the oil inlet and air inlet

For calculations with low ΔT values (i.e. below 10 °C), please contact our technical support staff.

OK EL1-6

Tolerance: $\pm 5\%$

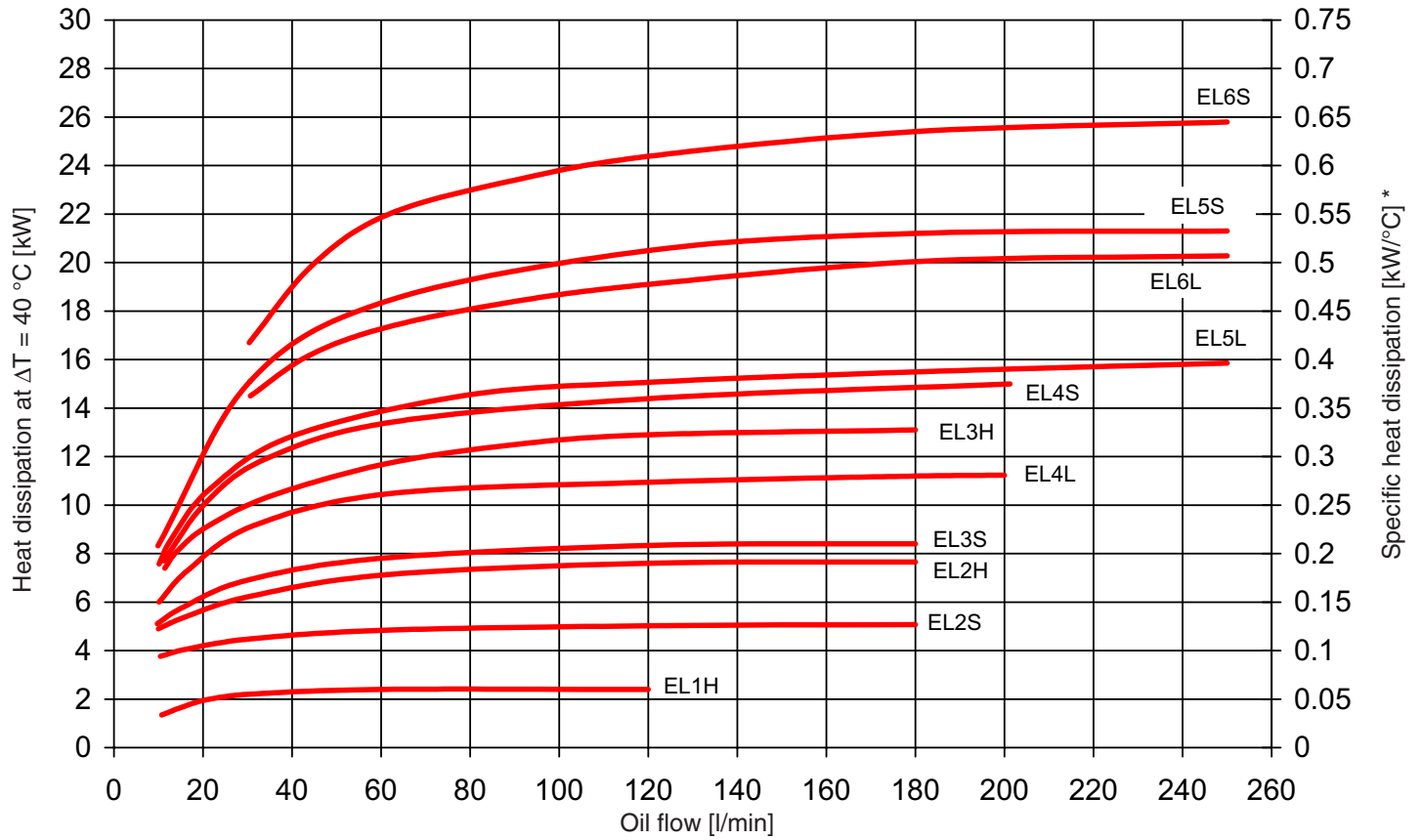

OK EL7-11

Tolerance: $\pm 5\%$

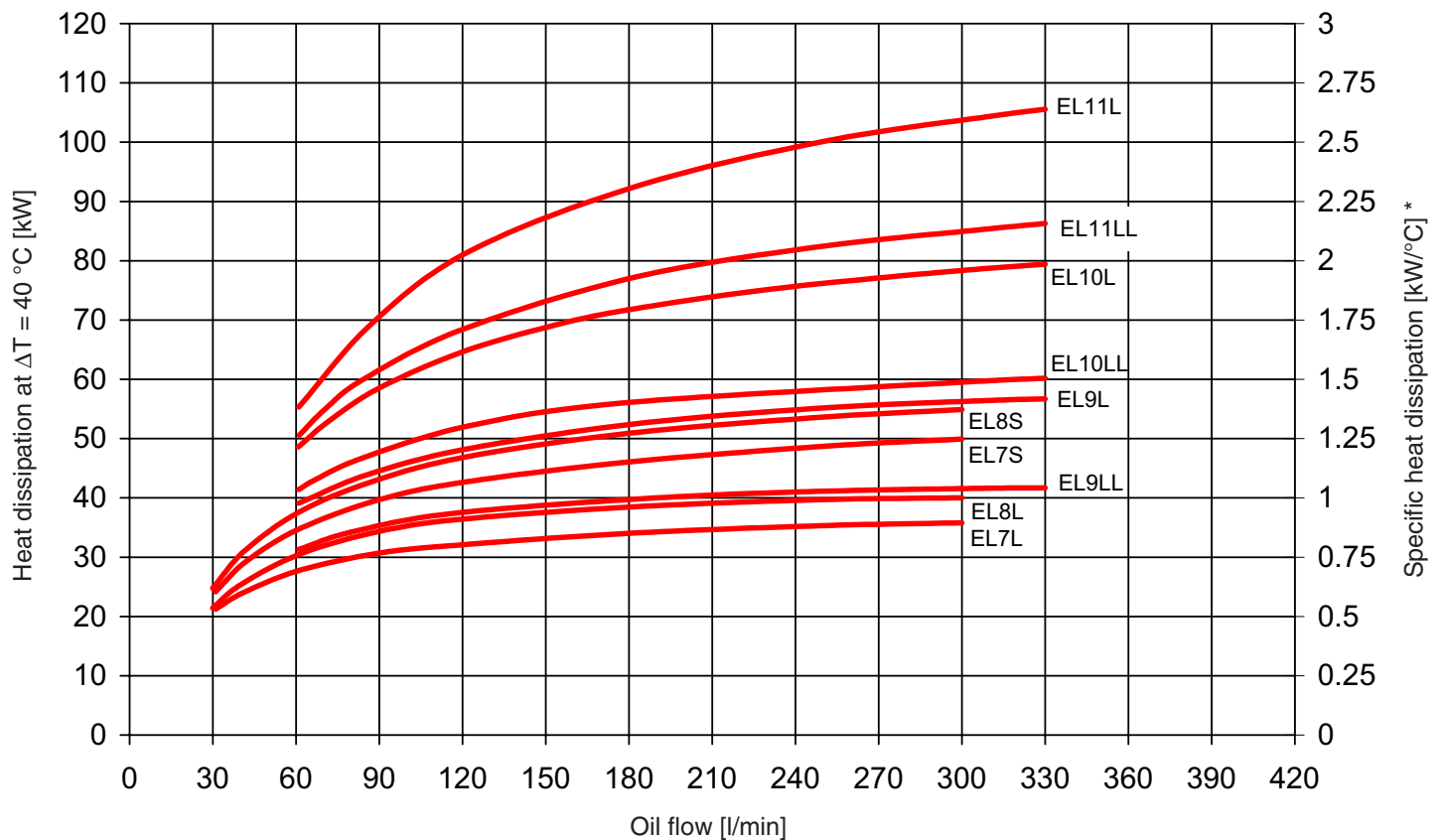

* Values measured at $\Delta T = 40\text{ °C}$, may vary at lower ΔT values

1.3.2 Pressure differential Δp :
measured at 30 mm²/s using mineral oil

Pressure drop curves OK EL1-6

Tolerance: $\pm 5\%$

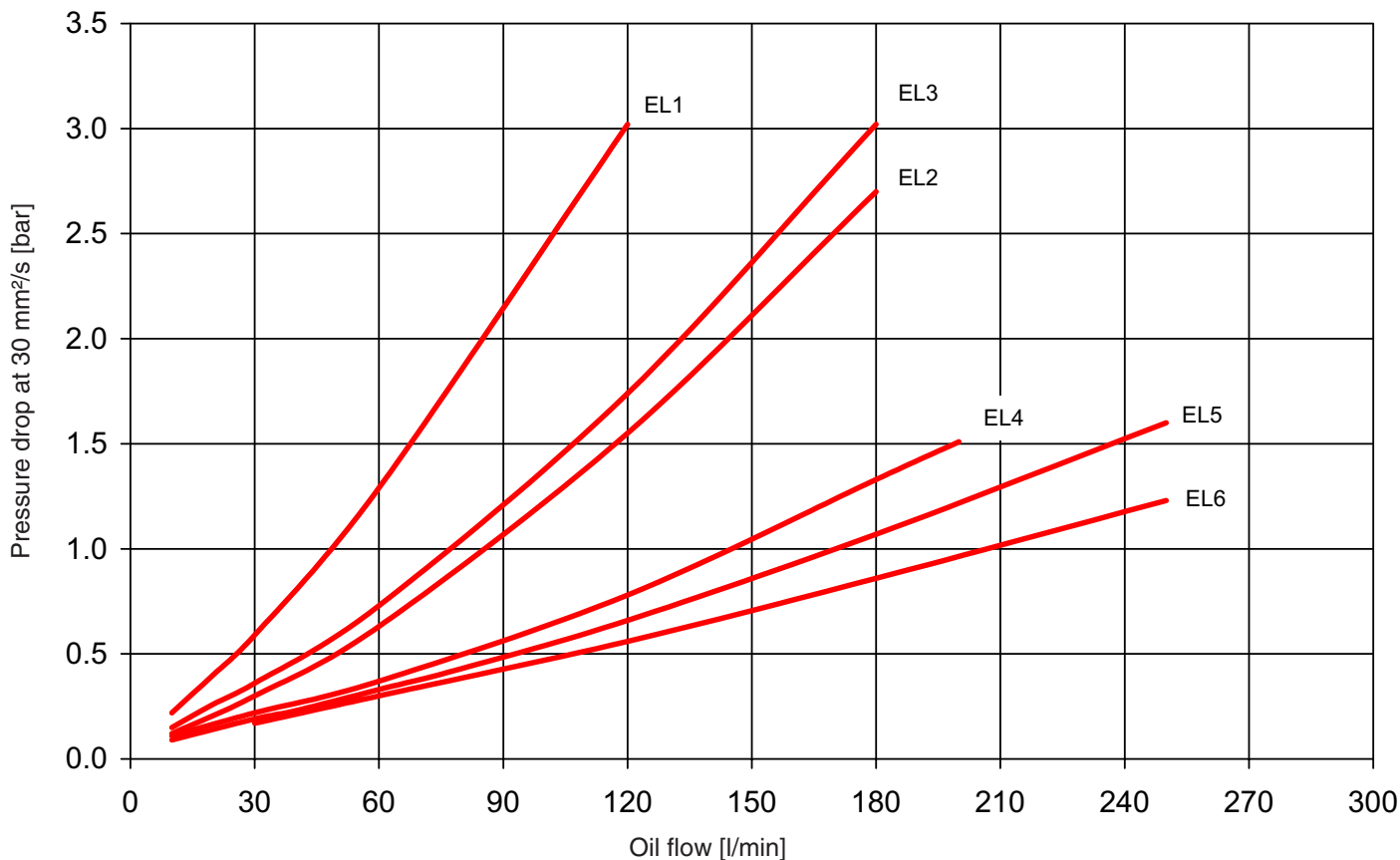

Pressure drop curves OK EL7-11

Tolerance: $\pm 5\%$

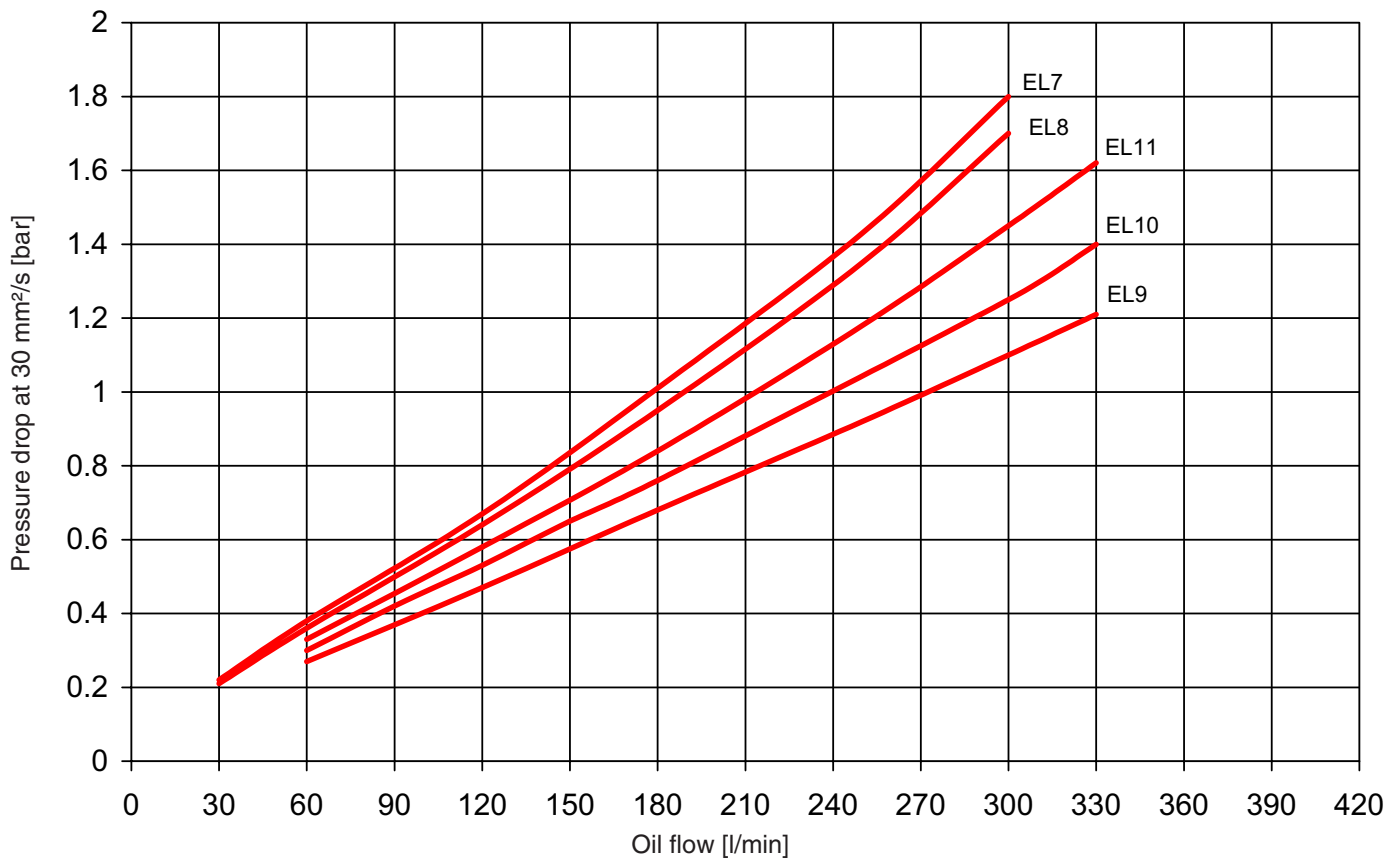

For other viscosities the result must be multiplied by K

Viscosity (mm ² /s)	10	15	22	30	46	68	100	150
Factor K	0.35	0.5	0.75	1	1.4	1.9	2.5	3.5

2. MODEL TYPE

(also order example)

OKAF-EL4S / 40 / 3 . 0 / B / M / A / LPF160 / 4 / 1 / IBT

Type of cooler

- OK-EL = Oil/air cooler
- OKA-EL = Oil/air cooler with built-in feed pump
- OKAF-EL = Oil/air cooler with built-in feed pump and filter

Size / motor speed

- 1-11 = See hydraulic details 1.3.
- LL = 8 pl (750 min⁻¹)
- L = 6 pl (1000 min⁻¹)
- S = 4 pl (1500 min⁻¹)
- H = 2 pl (3000 min⁻¹)

Displacement cm³/rev

- 28, 40 = (OKA/OKAF-EL4 -> EL6, see technical details 1.1.)
- 40, 58, 69 = (OKA/OKAF-EL8 -> EL11, see technical details 1.2.)

Type code and modification number

For the latest version of each cooler, please see the table in our internet site.

Clogging indicators (only OKAF)

- A = Without clogging indicator
- B = With visual indicator (*)
- C = With electrical indicator
- D = With electrical and optical indicator

Fluids

- M = Mineral oil to DIN 51524
- Other fluids on request

Motor voltage

- A = Standard voltages and frequencies for three-phase motor

50 Hz: 380 - 420 V (Y) / 220-240 V (Δ)
60 Hz: 440 - 480 V (Y) / 254-277 V (Δ)

Except for EL1, for which the standard voltage is 220-240 V, 50/60Hz, single phase

Other special voltages and frequencies on request and clearly written

Size of filter (only OKAF)

- OKAF-EL4-6 = LPF160
- OKAF-EL7-11 = LPF280

Filtration rating in micron, Viscosity up to 80 mm²/s (only OKAF)

- 8 = 5 μm Betamicon[®]-3-N (5 BN3HC)
- 4 = 10 μm Betamicon[®]-3-N (10 BN3HC) *
- 5 = 20 μm Betamicon[®]-3-N (20 BN3HC)

Paint

- 1 = RAL 5009 (Standard)
- Other paint on request and clearly written

Accessories

- AITF48 = Thermostat (fixed)
- IBP = Heat exchanger with integrated bypass valve
- IBT = Heat exchanger with integrated thermo-bypass valve
- GP = Vibration absorber

* standard for OKAF unless otherwise specified.

3. DIMENSIONS

3.1. OK-EL1

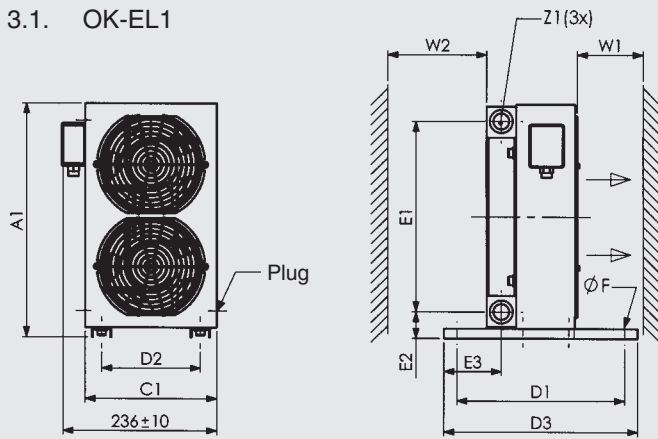

3.2. OK-EL2-6

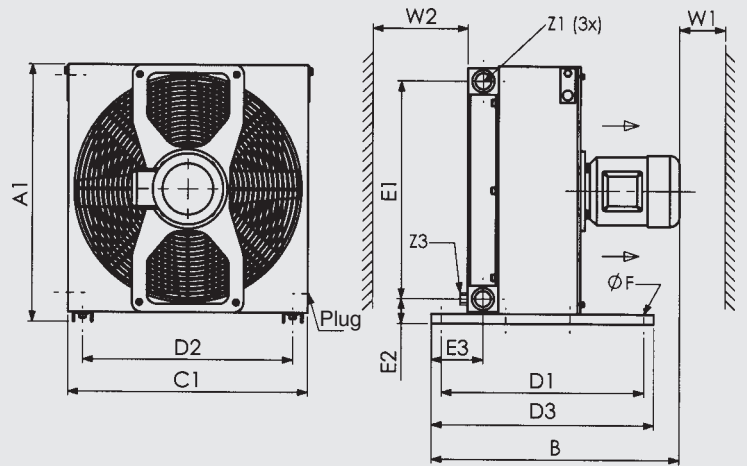

3.3. OK-EL7-8

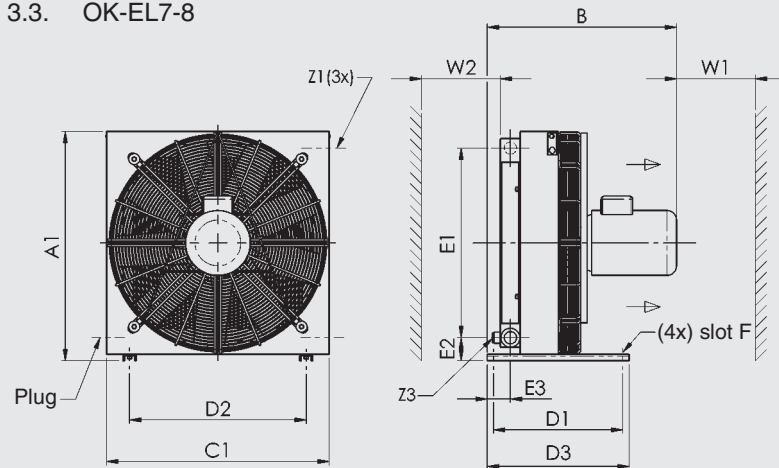

3.4. OK-EL9-11

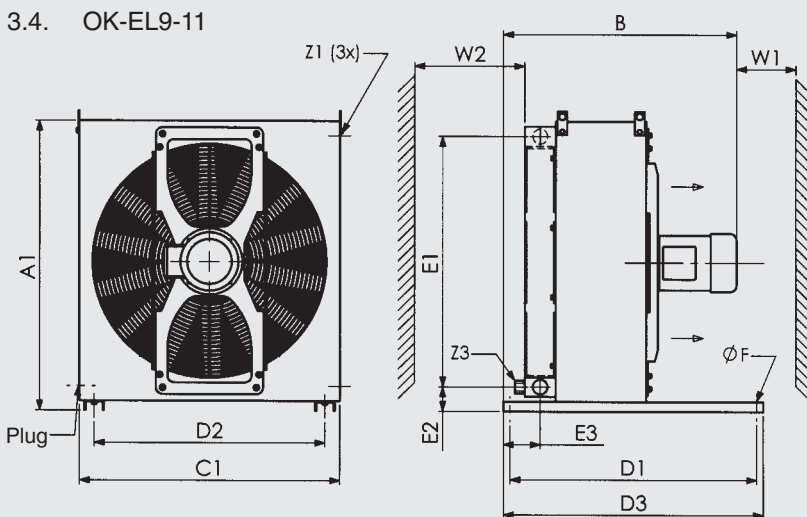

	A1 ±10	B ±25	C1 ±10	D1 ±2	D2 ±2	D3 ±2	E1 ±5	E2 ±5	E3 ±5	F Ø/slot	W1 Min.*	W2 Min.*	Z1	Z3
OK-EL1 H	355	–	200	255	150	295	289	41	88	9	150	100	G $\frac{3}{4}$ "	–
OK-EL2 S,H	355	400	330	255	160	295	289	41	58	9	500	200	G $\frac{3}{4}$ "	–
OK-EL3 S,H	455	420	380	255	290	295	389	41	58	9	800	300	G $\frac{3}{4}$ "	–
OK-EL4 L,S	520	527	485	410	425	450	439	51	104	9	1200	400	G1"	–
OK-EL5 L,S	562	580	542	410	482	450	439	72	94	9	1500	500	G1"	–
OK-EL6 L,S	640	600	584	410	482	450	500	80	74	9	1800	600	G1 $\frac{1}{4}$ "	M22x1.5
OK-EL7 L,S	726	612	706	410	560	450	600	73	74	9x20	1200	600	G1 $\frac{1}{4}$ "	M22x1.5
OK-EL8 L,S	726	612	706	410	560	450	630	58	74	9x20	1200	600	G1 $\frac{1}{4}$ "	M22x1.5
OK-EL9 L	880	709	790	750	700	790	760	75	116	12	2500	900	G1 $\frac{1}{2}$ "	M22x1.5
OK-EL10 L	1030	758	930	750	700	790	910	75	116	12	2800	900	G1 $\frac{1}{2}$ "	M22x1.5
OK-EL11 L	1180	804	1050	750	700	790	1060	75	116	12	3000	1000	G1 $\frac{1}{2}$ "	M22x1.5

* for smaller distances please contact our technical office

3.5. OKA/OKAF-EL4-6

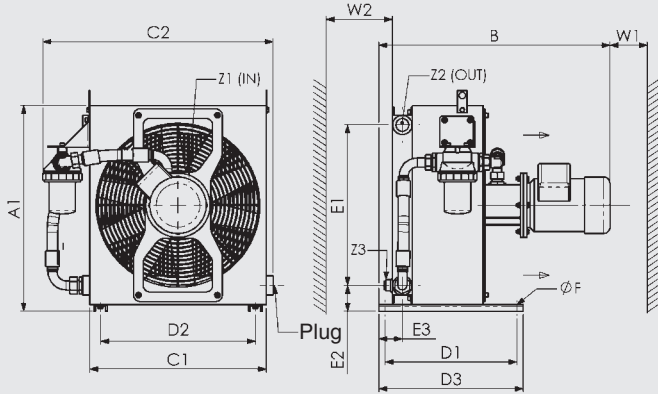

3.6. OKAF-EL7-8

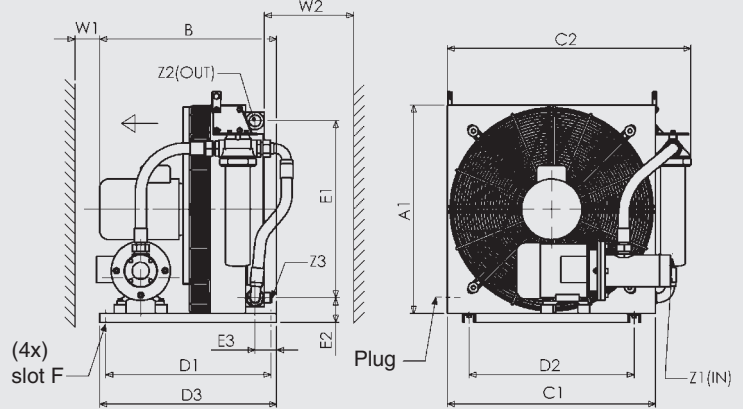

3.7. OKA/OKAF-EL9-11

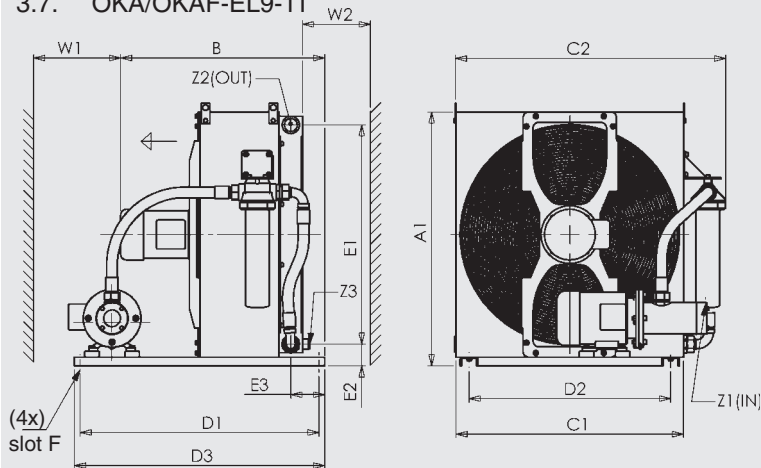

	A1 ±10	B ±25	C1 ±10	C2 ±25	D1 ±2	D2 ±2	D3 ±2	E1 ±5	E2 ±5	E3 ±5	F Ø/slot	W1 Min.*	W2 Min.*	Z1 (IN)	Z2(3x)	Z3
OKA-EL4 L,S	520	690	485	578	410	425	450	439	51	104	9	1200	400	G1 ¼"	G 1"	-
OKA-EL5 L,S	562	700	542	653	410	482	450	439	72	94	9	1500	500	G1 ¼"	G 1"	-
OKA-EL6 L,S	640	720	584	709	410	482	450	500	80	74	9	1800	600	G1 ¼"	G1 ¼"	M22x1.5
OKAF-EL4 L,S	520	690	485	631	410	425	450	439	51	104	9	1200	400	G1 ¼"	G 1"	-
OKAF-EL5 L,S	562	700	542	688	410	482	450	439	72	94	9	1500	500	G1 ¼"	G 1"	-
OKAF-EL6 L,S	640	720	584	725	410	482	450	500	80	74	9	1800	600	G1 ¼"	G1 ¼"	M22x1.5
OKA-EL7 L,S	736	612	706	775	560	560	600	600	83	74	9x20	1200	600	G 2"	G1 ¼"	M22x1.5
OKA-EL8 L,S	736	612	706	815	560	560	600	630	68	74	9x20	1200	600	G 2"	G1 ¼"	M22x1.5
OKA-EL9 L	880	709	790	910	830	700	870	760	75	116	12	2500	900	G 2"	G1 ½"	M22x1.5
OKA-EL10 L	1030	758	930	1050	830	700	870	910	75	116	12	2800	900	G 2"	G1 ½"	M22x1.5
OKA-EL11 L	1180	804	1050	1150	830	700	870	1060	75	116	12	3000	1000	G 2"	G1 ½"	M22x1.5
OKAF-EL7 L,S	736	612	706	825	560	560	600	600	83	74	9x20	1200	600	G 2"	G1 ¼"	M22x1.5
OKAF-EL8 L,S	736	612	706	846	560	560	600	630	68	74	9x20	1200	600	G 2"	G1 ¼"	M22x1.5
OKAF-EL9 L	880	709	790	936	830	700	870	760	75	116	12	2500	900	G 2"	G1 ½"	M22x1.5
OKAF-EL10 L	1030	758	930	1071	830	700	870	910	75	116	12	2800	900	G 2"	G1 ½"	M22x1.5
OKAF-EL11 L	1180	804	1050	1191	830	700	870	1060	75	116	12	3000	1000	G 2"	G1 ½"	M22x1.5

* for smaller distances please contact our technical office

4. CERTIFICATION FOLLOWING EN 1048

Hydac SA design and manufacture high quality coolers that are tested and certified to give reliable and repeatable high performance. To ensure the performance is accurate, testing in compliance with a recognized international test standard is the best solution. For air/liquid coolers this is EN1048.

Hydac SA test procedure complies with the requirements of EN 1048 and both the procedure and test equipment are independently inspected and certified by TÜV SÜDDEUTSCHLAND.

The cooler performance details in this brochure have been tested following EN 1048.



5. NOTE

The information in this brochure relates to the operating conditions and applications described.

For applications or operating conditions not described, please contact the relevant technical department. Subject to technical modifications.