

# HAND LEVER MODULATING BRAKE VALVE

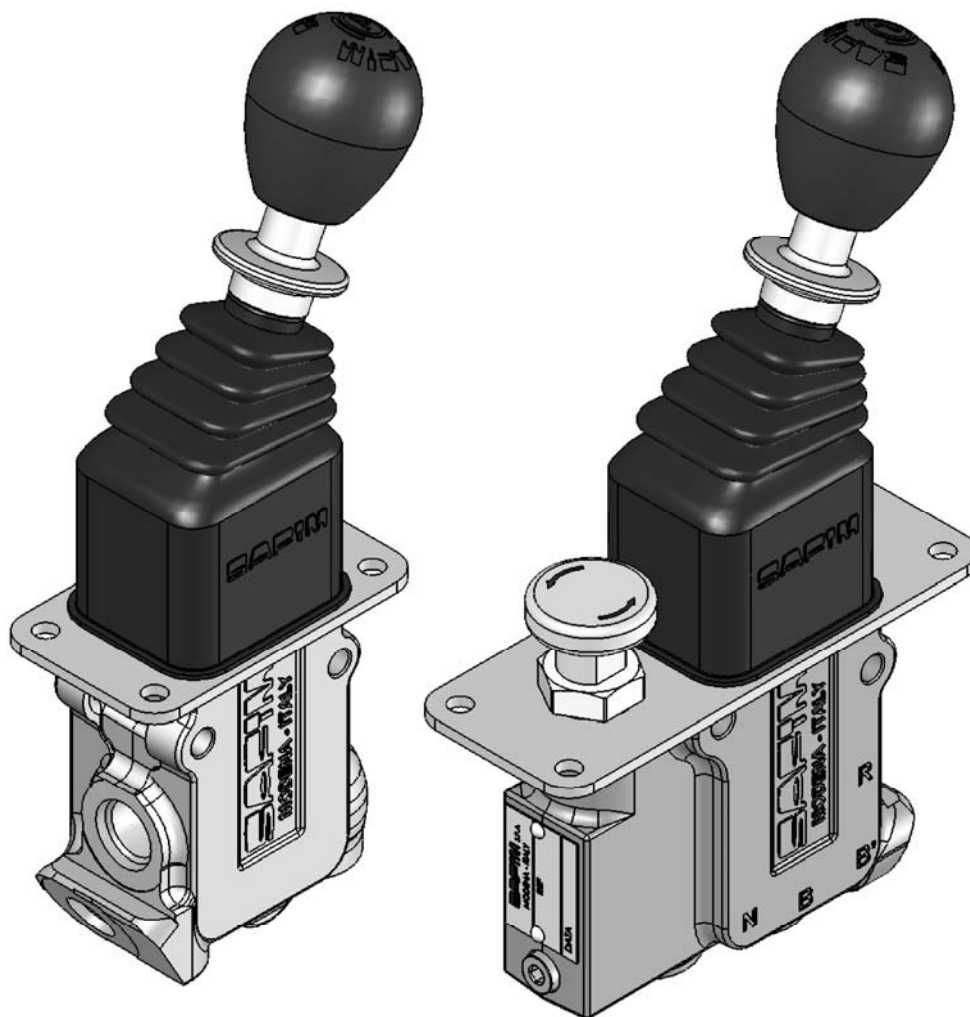

**SAFIM** S.p.A.  
SVILUPPO APPLICAZIONI FRENI INDUSTRIALI



### 010.010 OPERATING PRINCIPLES

Hand lever modulating brake valve works as a manually operated 3-ways pressure reducing valve, with inverse modulation to operate spring apply hydraulically operated brake.

When the lever is in position 1 a pressure PS (release pressure) independent from pressure R, is supplied to the negative braking system through connection B.

This pressure must be enough to fully release negative brake.

With a movement of 4°, pressure falls to the value of Pi (initial modulation pressure) that allows the negative braking system to make contact.

By rotating the lever again, pressure decreases in a proportional way, reaching value Pf (final modulation pressure). A wide angle is available (around 40°) to modulate braking in the pressure interval when the negative braking system intervenes.

With a further 7° rotation, pressure gets to zero (see diagram 050.010). A mechanical blocking device inside the control lever allows the operator to release the lever and keep the vehicle stopped (lever in position 2).

### 010.020 MAIN CHARACTERISTICS

- Careful regulation of braking force thanks to the unique characteristic “rotation-pressure” that allows a wide interval of proportionality in the pressures interval.
- Quick reaction thanks to big internal passages.
- Operating lever force is very reduced.
- Installation online.
- Reduced dimensions.
- Optional integrated hand pump to release the brake.

### SYSTEM SCHEME

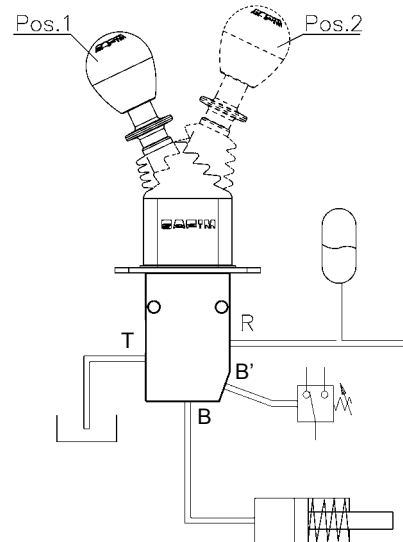

### HYDRAULIC SCHEME

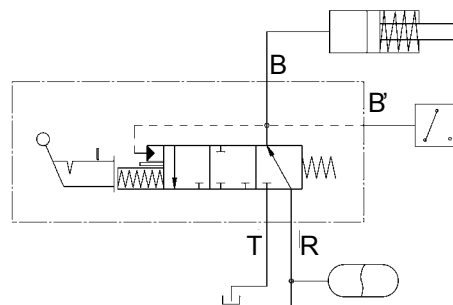

### 020.010 CONNECTIONS

R	Feed pressure	T	Tank
B	Spring actuated brake cylinder	B'	Pressure switch port

### 030.010 TECHNICAL FEATURES

Max pressure in R	210 Bar
Max pressure in T	0.5 Bar
Fluid type	Mineral oil
Contamination level of the fluid (max allowed)	NAS 1638 type 8
Temperature interval	-20°C / +90°C

### 040.010 OVERALL DIMENSIONS - 203196/\_\_\_ 2 D\_ (STANDARD)

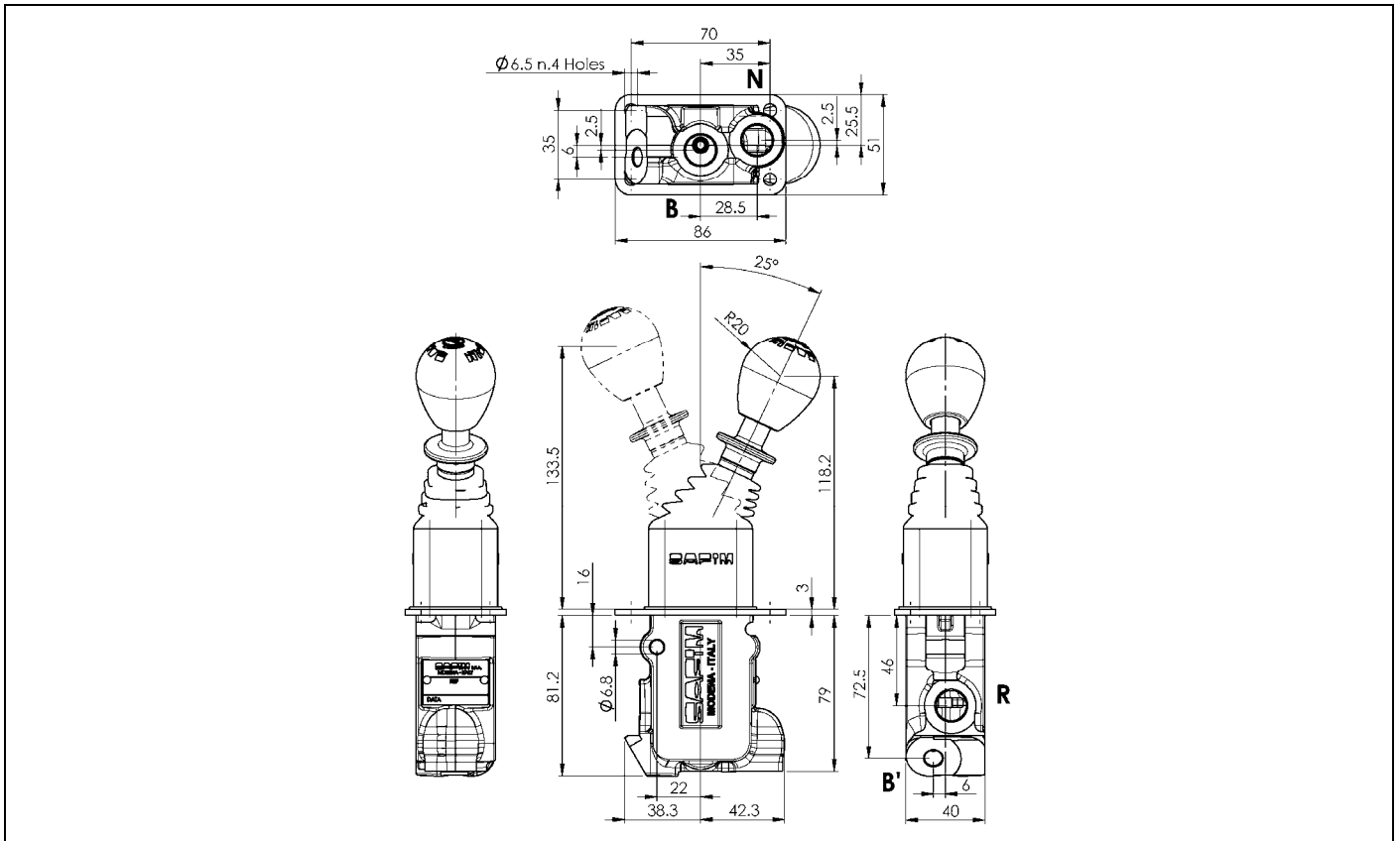

### 040.020 OVERALL DIMENSIONS - 203600/\_\_\_ 2 D\_ (WITH HAND PUMP)

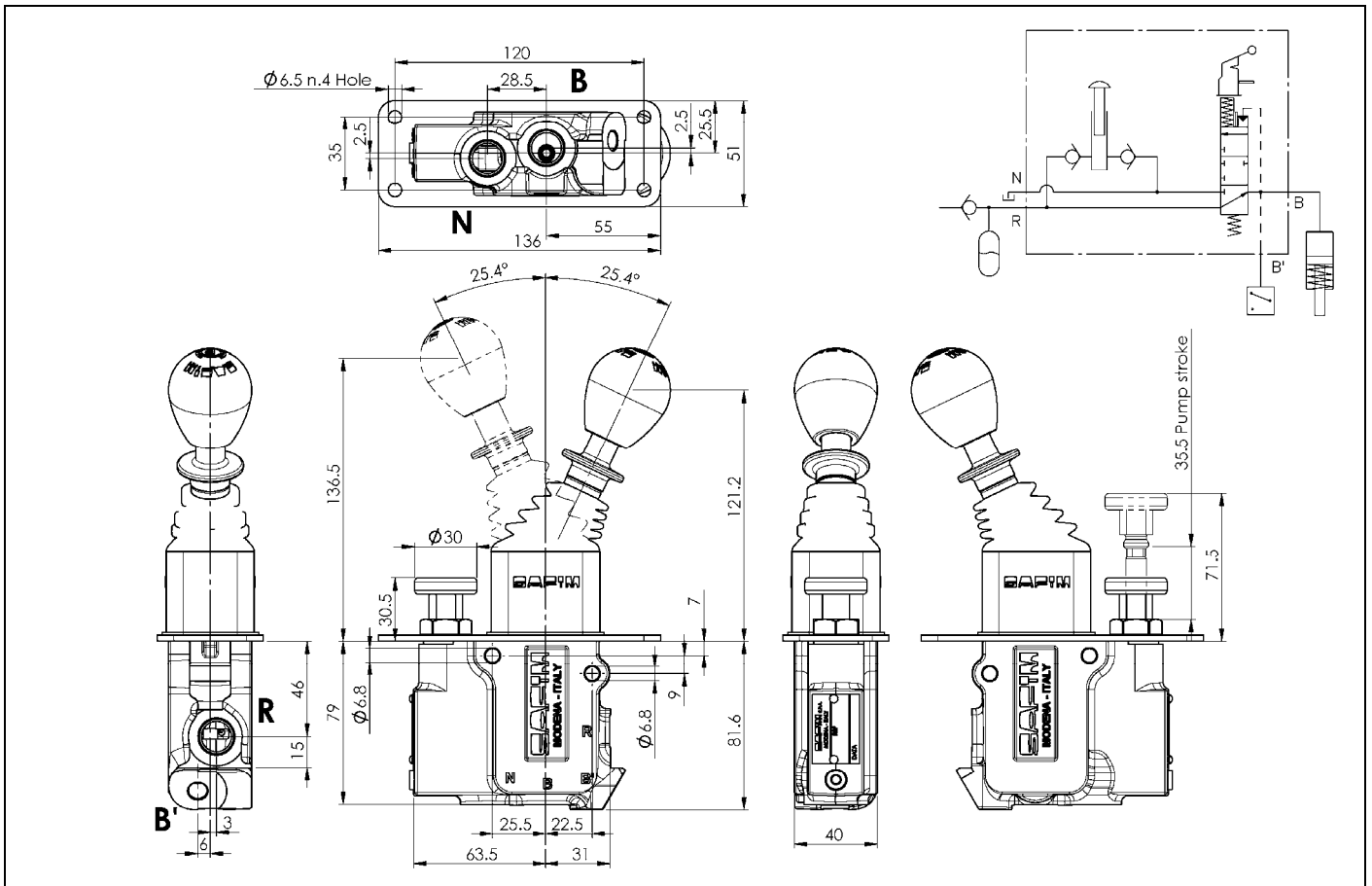

### 050.010 MODULATION CURVE CHOICE

The choice of the modulation curve is crucial to obtain a perfect brake modulation.

A negative cylinder is characterized by some technical features that are important to choose the correct setting for the proportional operating:

- Pmax: max pressure allowed.
- Pmin: min pressure to obtain a complete release fully open.
- P1: pressure value at which the braking surface is in contact and braking starts.
- P2: pressure value at which braking is so strong that pressure reduction is not useful.

Pmax and Pmin are two precise values that can be deduced from brake characteristics.

P1 is important to choose the correct setting of the lever. It is a typical data of the brakes.

P2 may assume a value between 0 and "some" Bar and corresponds to the pressure value at which the brakes makes such a strong force that more deceleration is not useful.

Values P1 and P2 can also be easily deduced from a diagram pressure-deceleration relative to the vehicle.

The scope of the specific curve, that characterizes Safim's modulating valve, is to increase the modulation interval between pressures P1 and P2 to the utmost (effective working pressures of negative brake) and guarantee a certain release and the stopping of the vehicle at max force supplied by the brake.

#### Release pressures (Ps)

The value of release pressure (Ps) indicates the pressure necessary to keep negative brake disconnected. This value must be included between maximum pressure that can be accepted by the cylinder (Pmax) and minimum pressure, therefore the brake is completely released (Pmin).

#### Diagram

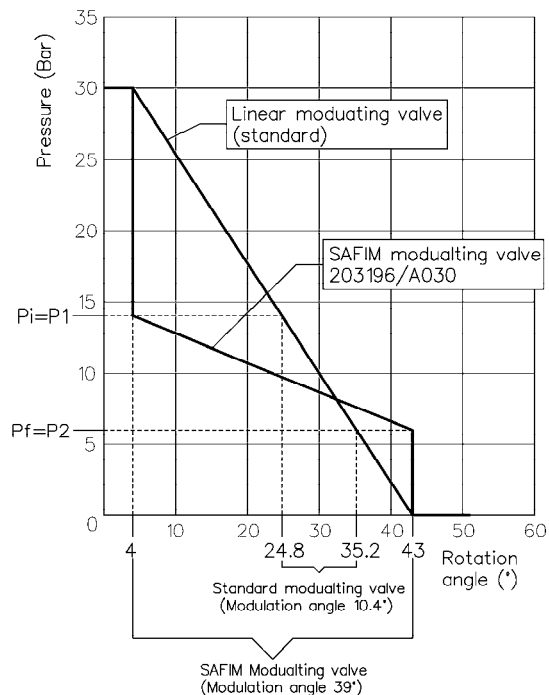

#### Initial modulation pressure (Pi)

Initial modulation pressure (Pi) must be close to the pressure value, therefore, the negative cylinder makes contacts within the braking unit (P1).

#### Final modulation pressure (Pf)

Final modulation pressure (Pf) must be close to the pressure value, therefore, the negative cylinder supplies such a strong braking force that deceleration ends and the vehicle stops (P2).

### 060.010 HYDRAULIC SCHEMES OF MODULATING VALVE FEEDING

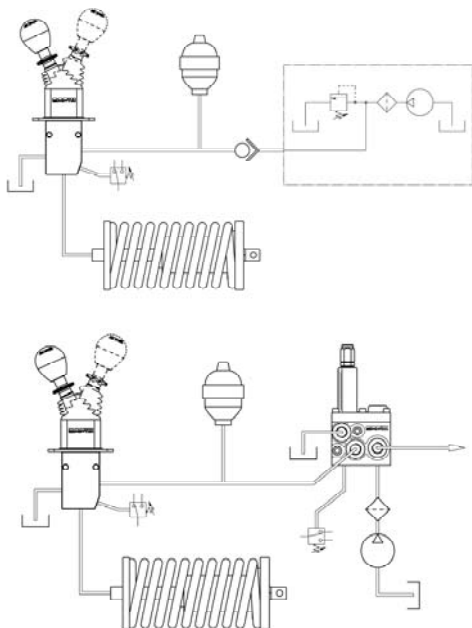

Proportional lever can be fed by a steady pressure circuit on the vehicle provided pressure does not exceed 210Bar.

In case there is not any steady pressure line on the vehicle, SAFIM's modulating valve can be fed by an accumulator charging valve.

### 070.010 PURCHASING PART NUMBER

In the following we advise on how to gain purchase order part number of the lever in order to define all its operating and geometric characteristics.

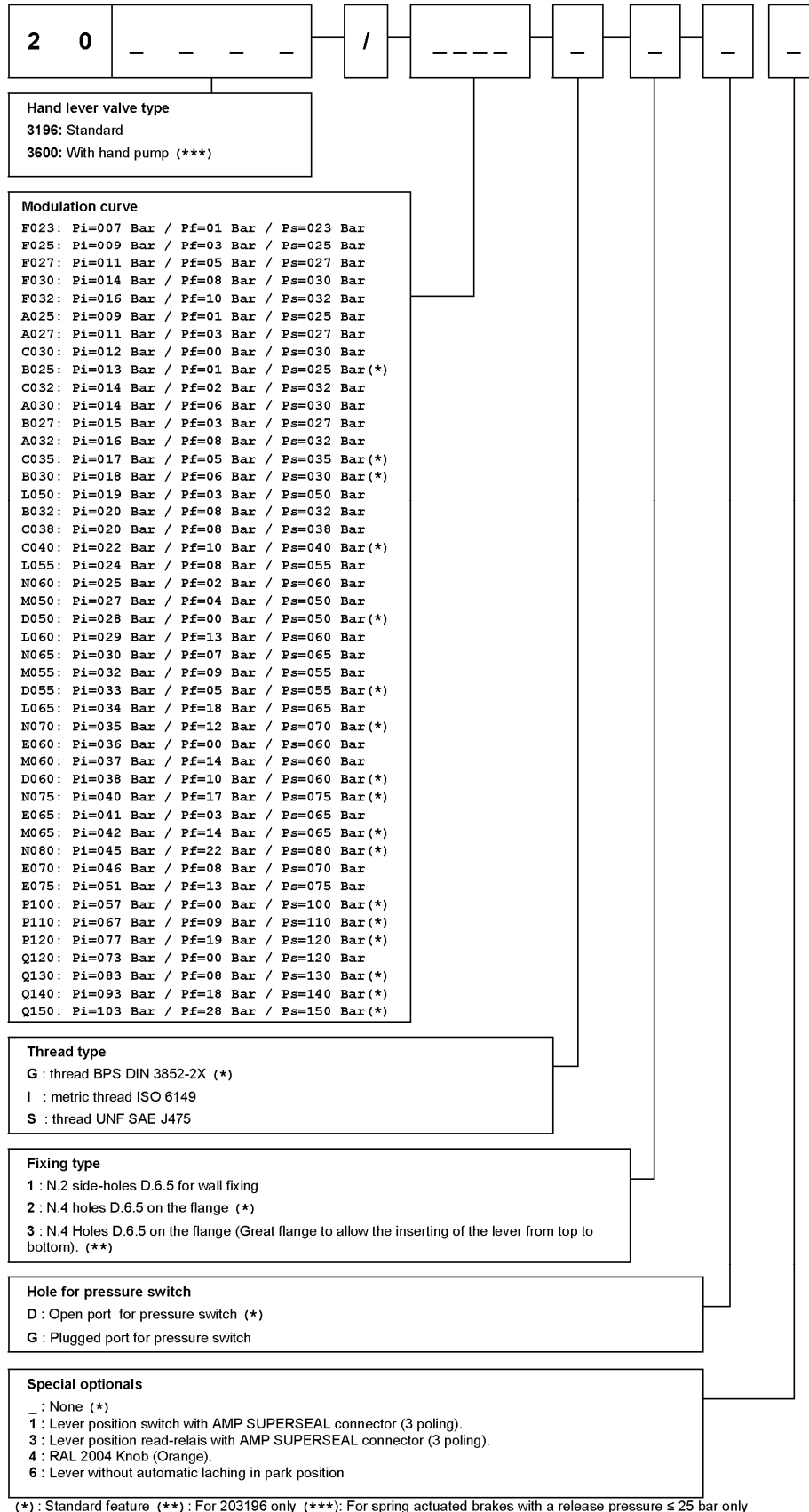

### 070.020 HAND LEVER TYPE

**203196/.....** identifies the standard hand lever modulating brake valve with compact body and without hand pump.

**203600/....** identifies the hand lever modulating brake valve with integrated hand pump to release the spring actuated cylinder.

The hand pump catches oil from tank line and supplies it to the cylinder line.

The pump piston diameter is 10mm, and it permits to reach a pressure of 25 Bar with a hand force of 20 daN (It is not useful if the cylinder release pressure is more than 25 Bar).

### 070.030 MODULATION CURVE

Modulation curve is defined by three values  $P_i$  (initial modulation pressure),  $P_f$  (final modulation pressure) and  $P_s$  (release pressure).

Different curves available are classified according to their most typical value, which is initial modulation pressure  $P_i$ .

The letter identifies pressure fall  $P_i - P_f$  and  $P_s - P_i$ :

**A:**  $P_i - P_f = 8$  Bar,  $P_s - P_i = 16$  Bar

**B:**  $P_i - P_f = 12$  Bar,  $P_s - P_i = 12$  Bar

**C:**  $P_i - P_f = 12$  Bar,  $P_s - P_i = 18$  Bar

**D:**  $P_i - P_f = 29$  Bar,  $P_s - P_i = 22$  Bar

**E:**  $P_i - P_f = 38$  Bar,  $P_s - P_i = 24$  Bar

**L:**  $P_i - P_f = 16$  Bar,  $P_s - P_i = 31$  Bar

**M:**  $P_i - P_f = 23$  Bar,  $P_s - P_i = 23$  Bar

**N:**  $P_i - P_f = 23$  Bar,  $P_s - P_i = 35$  Bar

**P:**  $P_i - P_f = 58$  Bar,  $P_s - P_i = 43$  Bar

**Q:**  $P_i - P_f = 76$  Bar,  $P_s - P_i = 47$  Bar

The following number identifies  $P_s$  value

### 070.040 THREAD TYPE

Port	<b>G</b>	<b>I</b>	<b>S</b>
	(20___/___ <b>G</b> ___)	(20___/___ <b>I</b> ___)	(20___/___ <b>S</b> ___)
	Thread BPS DIN 3852-2X	Metric thread ISO 6149	Thread UNF SAE J475
<b>R (Accumulator)</b>	G 3/8 DIN 3852-2X	M16x1.5 ISO 6149	9/16-18 UNF SAE J475 (SAE#6)
<b>T (Tank)</b>	G 3/8 DIN 3852-2X	M16x1.5 ISO 6149	9/16-18 UNF SAE J475 (SAE#6)
<b>B (Negative brake)</b>	G 3/8 DIN 3852-2X	M16x1.5 ISO 6149	9/16-18 UNF SAE J475 (SAE#6)
<b>B' (Pressure switch)</b>	M10x1 DIN 3852-1X	M10x1 DIN 3852-1X	7/16-20 UNF SAE J475 (SAE#4)

Thread BPS DIN 3852-2X	<table border="1"> <thead> <tr> <th>A</th> <th>B</th> <th>C</th> </tr> </thead> <tbody> <tr> <td style="text-align: center;">G 3/8</td> <td style="text-align: center;"><math>\varnothing 16.7_0^{+0.2}</math></td> <td style="text-align: center;">12</td> </tr> </tbody> </table>	A	B	C	G 3/8	$\varnothing 16.7_0^{+0.2}$	12						
A	B	C											
G 3/8	$\varnothing 16.7_0^{+0.2}$	12											
Metric thread ISO 6149	<table border="1"> <thead> <tr> <th>A</th> <th>B</th> <th>C</th> <th>D</th> <th>E</th> <th>F</th> </tr> </thead> <tbody> <tr> <td style="text-align: center;">M16x1.5</td> <td style="text-align: center;"><math>17.8_0^{+0.1}</math></td> <td style="text-align: center;"><math>2.4_0^{+0.4}</math></td> <td style="text-align: center;">15°</td> <td style="text-align: center;">45°</td> <td style="text-align: center;">13</td> </tr> </tbody> </table>	A	B	C	D	E	F	M16x1.5	$17.8_0^{+0.1}$	$2.4_0^{+0.4}$	15°	45°	13
A	B	C	D	E	F								
M16x1.5	$17.8_0^{+0.1}$	$2.4_0^{+0.4}$	15°	45°	13								

Thread UNF SAE J475	A	B +/-0.05	C +/-0.2	D +/-r	E	E
	7/16-20 UNF (SAE 4)	12.45	2.5	12°	45°	12
	9/16-18 UNF (SAE 6)	15.7	2.7	12°	45°	13

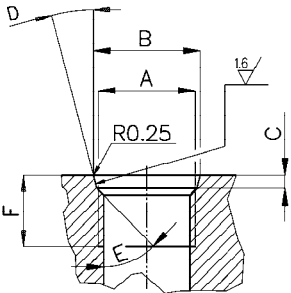

### 070.050 FIXING TYPE

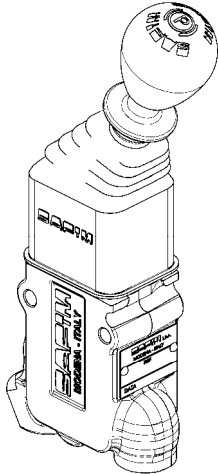
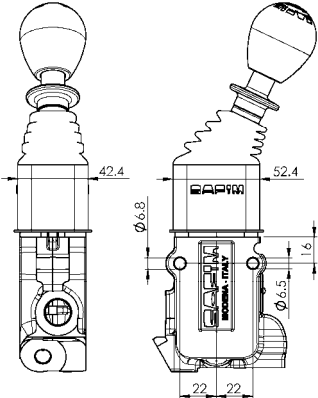
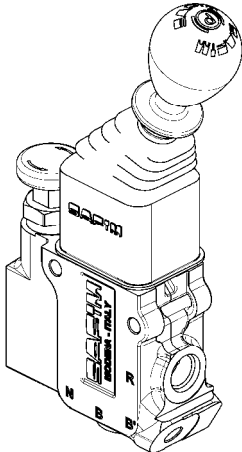
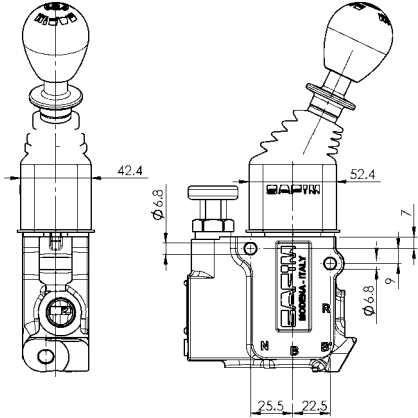
<p>1: SIDE FIXING (203196/____1__)</p>		
<p>1: SIDE FIXING (203600/____1__)</p>		

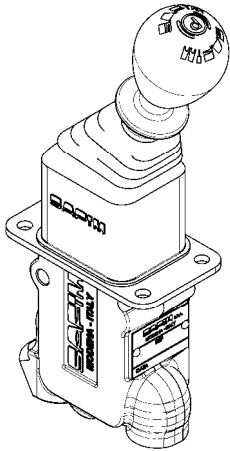
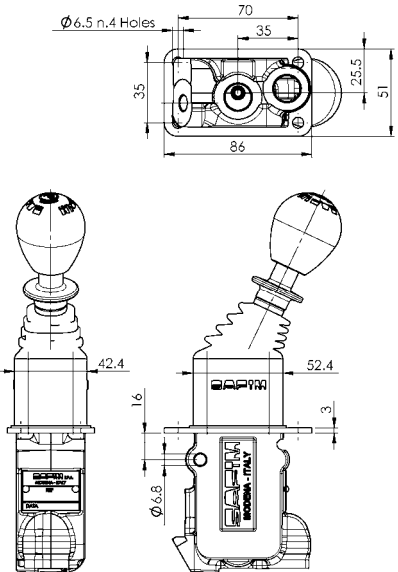
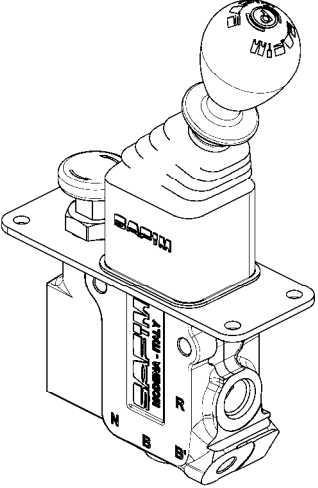
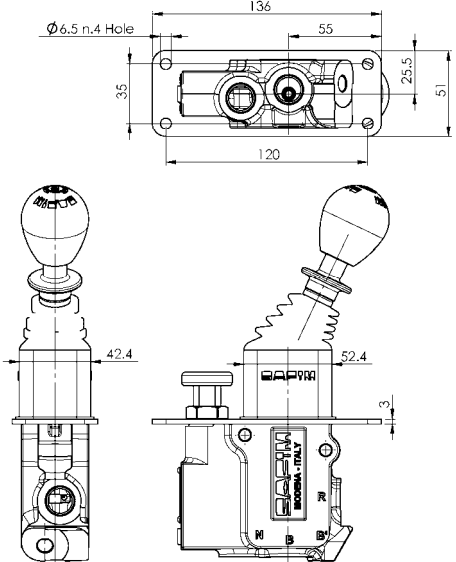
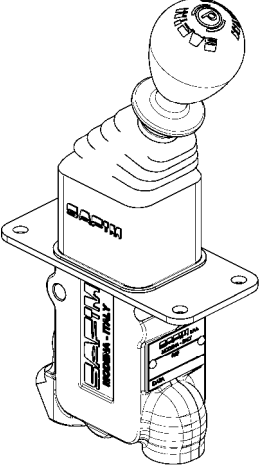
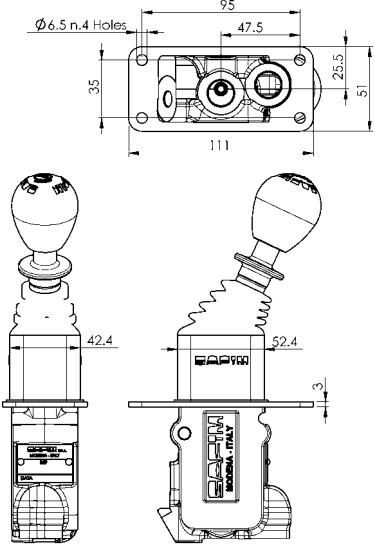
<p>2: FIXING ON FLANGE (203196/___2___)</p>		
<p>2: FIXING ON FLANGE (203600/___2___)</p>		
<p>3: FIXING ON FLANGE (203196/___3___)</p>		

### 070.060 HOLE FOR PRESSURE SWITCH

**D:** Pressure switch port is open (203196/\_\_\_\_D\_)

**G:** Pressure switch port is plugged (203196/\_\_\_\_G\_)

### 080.070 OPTIONALS

\_: Without any optionals (20\_\_\_\_/\_\_\_\_).

**1:** Lever position switch with AMP SUPERSEAL 1.5 series connector (3 poling) (20\_\_\_\_/\_\_\_\_ 1).

**3:** Lever position reed-switch with AMP SUPERSEAL 1.5 series connector (3 poling) (20\_\_\_\_/\_\_\_\_ 3).

Connector pin description:

- 3: NO pin**
- 2: NC pin**
- 1: Common pin**

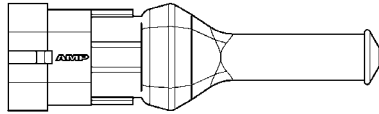

Leads length: 250mm

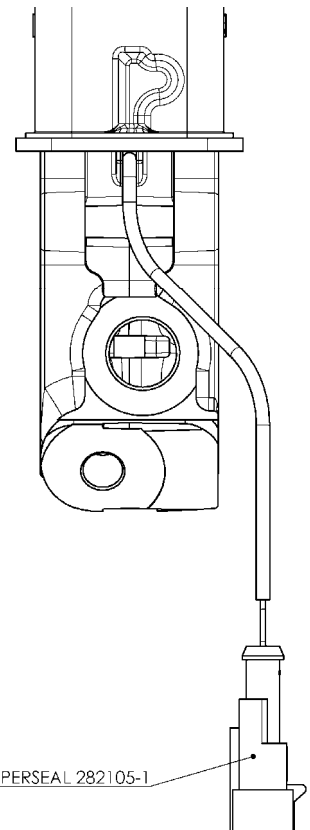
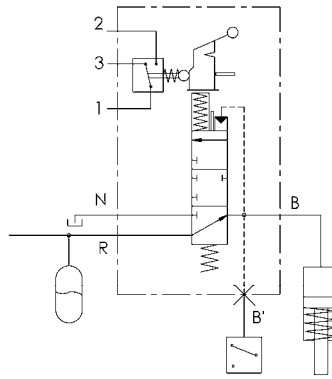
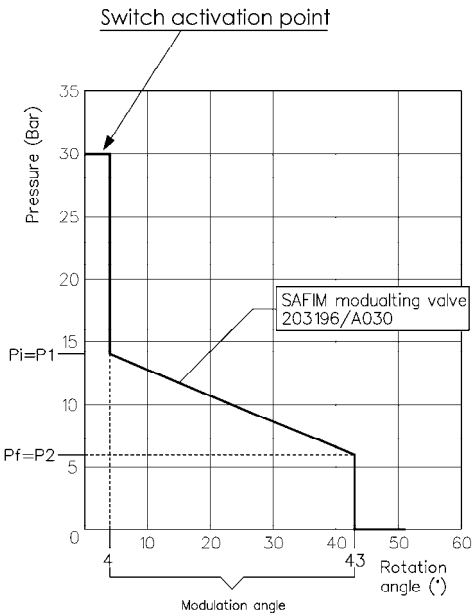

The switch is actuated when the lever is in position 1 (Rotation angle = 0°)

#### SWITCH TECHNICAL FEATURES (1)

Current            0.005 – 2 A (12 VDC)  
Voltage            12VDC  
Protection        IP67

#### REED-SWITCH TECHNICAL FEATURES (2)

Max power        3 W  
Max current      0.25 A  
Max voltage      50 V  
Protection        IP67

**4:** RAL 2004 orange Knob (20\_\_\_\_/\_\_\_\_ 4).

An Orange Knob, in vice of the standard black one, is available to identify the lever like a safety component.

### 6: Lever without automatic latching in park position.

The standard latch system block automatically the lever when the end modulation position is reached. A special latching system permits the full modulation without automatic latching of the lever. The driver can lock the lever manually.

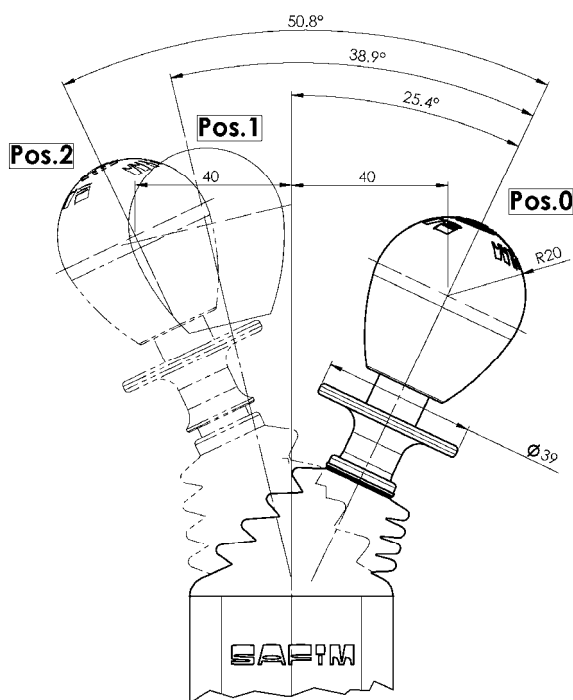

### DIAGRAM

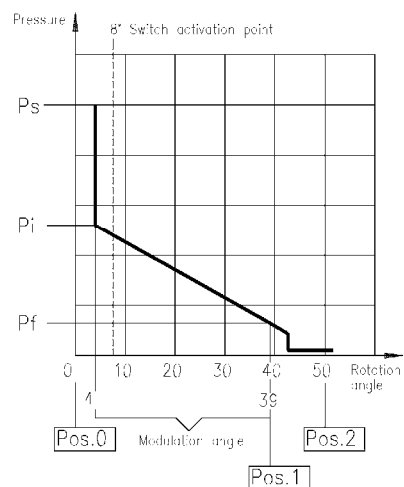

### LEVER POSITIONS

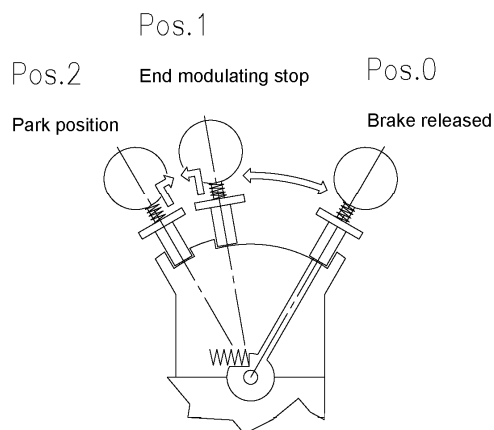

**NOTE:** It is possible to combine more than one special option. Please ask Safim technical dpt for correct P/N.