

# Compact cylinder, Series KPZ

- Ø 16-100 mm
- Ports M5 G 1/8
- double-acting
- with magnetic piston
- Cushioning elastic
- Piston rod Internal thread
- Piston rod Optionally through
- ATEX optional
- Optionally heat-resistant



Standards	NFE 49004
Certificates	ATEX optional
Compressed air connection	Internal thread
Ambient temperature min./max.	-20 ... 80 °C
Medium temperature min./max.	-20 ... 80 °C
Medium	Compressed air
Max. particle size	50 µm
Oil content of compressed air	0 ... 5 mg/m <sup>3</sup>
Pressure for determining piston forces	6.3 bar

## Technical data

Piston Ø Piston rod thread Ports	16 mm M4 M5	20 mm M6 M5	25 mm M6 M5	32 mm M8 G 1/8	40 mm M8 G 1/8	50 mm M10 G 1/8
Stroke 5	0822390000	0822391000	0822392000	0822393000	0822394000	0822395000
10	0822390001	0822391001	0822392001	0822393001	0822394001	0822395001
15	0822390002	0822391002	0822392002	0822393002	0822394002	0822395002
20	0822390003	0822391003	0822392003	0822393003	0822394003	0822395003
25	0822390004	0822391004	0822392004	0822393004	0822394004	0822395004
30	0822390005	0822391005	0822392005	0822393005	0822394005	0822395005
40	0822390006	0822391006	0822392006	0822393006	0822394006	0822395006
50	0822390007	0822391007	0822392007	0822393007	0822394007	0822395007
60	0822390008	0822391008	0822392008	0822393008	0822394008	0822395008
80	-	-	-	0822393009	0822394009	0822395009
100	-	-	-	0822393010	0822394010	0822395010

Piston Ø Piston rod thread Ports	63 mm M10 G 1/8	80 mm M12 G 1/8	100 mm M16 G 1/8
Stroke 5	0822396000	0822397000	0822398000
10	0822396001	0822397001	0822398001
15	0822396002	0822397002	0822398002
20	0822396003	0822397003	0822398003
25	0822396004	0822397004	0822398004
30	0822396005	0822397005	0822398005
40	0822396006	0822397006	0822398006
50	0822396007	0822397007	0822398007
60	0822396008	0822397008	0822398008
80	0822396009	0822397009	0822398009
100	0822396010	0822397010	0822398010

## Technical data

Piston Ø	16 mm	20 mm
Retracting piston force	95 N	148 N
Extracting piston force	127 N	198 N
Impact energy	0,15 J	0,2 J
Working pressure min./max.	1 ... 10 bar	1 ... 10 bar
Sealing material	Nitrile butadiene rubber	Nitrile butadiene rubber
Stroke max.	300 mm	300 mm

Piston Ø	25 mm	32 mm	40 mm
Retracting piston force	260 N	435 N	720 N
Extracting piston force	309 N	507 N	792 N
Impact energy	0,3 J	0,5 J	0,7 J
Working pressure min./max.	1 ... 10 bar	0,6 ... 10 bar	0,6 ... 10 bar
Sealing material	Nitrile butadiene rubber	Polyurethane	Polyurethane
Stroke max.	300 mm	300 mm	300 mm

Piston Ø	50 mm	63 mm	80 mm	100 mm
Retracting piston force	1110 N	1827 N	2969 N	4639 N
Extracting piston force	1237 N	1964 N	3167 N	4948 N
Impact energy	1 J	1,3 J	1,8 J	2,5 J
Working pressure min./max.	0,6 ... 10 bar	0,6 ... 10 bar	0,6 ... 10 bar	0,6 ... 10 bar
Sealing material	Polyurethane	Polyurethane	Polyurethane	Polyurethane
Stroke max.	300 mm	300 mm	500 mm	500 mm

## Technical information

The pressure dew point must be at least 15 °C under ambient and medium temperature and may not exceed 3 °C .

The oil content of compressed air must remain constant during the life cycle.

Use only the approved oils from AVENTICS. Further information can be found in the "Technical information" document (available in the MediaCentre).

ATEX-certified cylinders with identification II 2G c IIB T4 / II 2D c IP65 T135°C X can be generated in the Internet configurator. The operating temperature range for ATEX-certified cylinders is - 20 °C ... 50 °C .  
 The material for heat-resistant scraper and seal variants (ambient temperature: - 10 °C - 120 °C ) is fluorocautchouc.  
 Further options can be generated in the Internet configurator.

## Technical information

Material	
Cylinder tube	Aluminum, anodized
Piston rod	Stainless steel
Front cover	Aluminum
End cover	Aluminum
Seal	Nitrile butadiene rubber Polyurethane
Scraper	Polyurethane

## Dimensions

### Dimensions

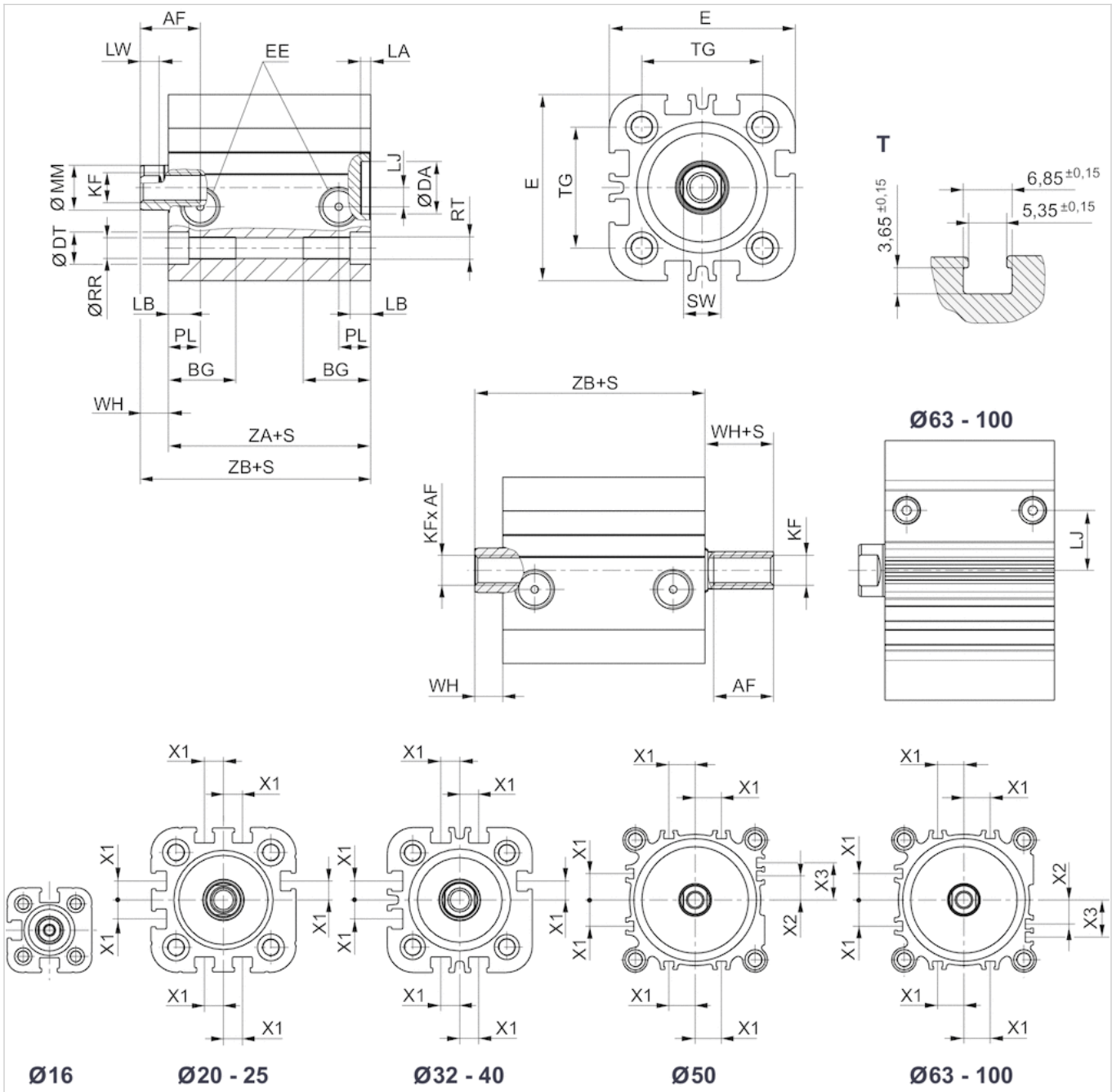

S = stroke  
T = View for sensor groove

## Dimensions

Piston Ø	AF 1)	BG 1)	DA H11	DT H13	E	EE	KF	LA	LB	LJ	LW
16 mm	10	14.5	10	6	29.5	M5	M4	2.5	3.5	2.5	2.8
20 mm	12	15.5	12	7.5	36	M5	M6	2.5	4.5	4.5	3.7
25 mm	12 10: S3 mm 2)	15.5	12	8	40	M5	M6	2.5	4.4	5	3.7
32 mm	12	18	14	8.6	50	G 1/8	M8	2.5	5.5	5.1	5

Piston Ø	AF 1)	BG 1)	DA H11	DT H13	E	EE	KF	LA	LB	LJ	LW
40 mm	12	18	14	9	58	G 1/8	M8	2.5	5.5	9.6	5
50 mm	16 12: S4 mm 2)	24	18	11	68	G 1/8	M10	2.5	2	8.5	4.8
63 mm	16 12: S4 mm 2)	24	18	11	80	G 1/8	M10	2.5	2	17.8	4.8
80 mm	20 15: S5 mm 2)	28	23	14	99	G 1/8	M12	3	1	22.9	6.4
100 mm	26 21: S5 mm 2)	27.5	28	15	120	G 1/8	M16	3	3.5	26.5	6.4

Piston Ø	MM f8	PL	Ø RR	RT	SW	TG	WH	X1	X2	X3	ZA +S	ZB +S
16 mm	8	7.5	3.3	M4	7	18 ±0,4	4.5	-	-	-	38	42,5 0/+1,4
20 mm	10	7.5	4.2	M5	8	22 ±0,4	5	4.2	-	-	38	43 0/+1,4
25 mm	10	7.5	4.2	M5	8	26 ±0,4	5.5	4.5	-	-	39	44,5 0/+1,4
32 mm	12	8.5	5.1	M6	10	32 ±0,5	7	6.5	-	-	44	51 0/+1,6
40 mm	12	8.5	5.1	M6	10	42 ±0,5	7	11	-	-	45	52 0/+1,6
50 mm	16	8.5	6.7	M8	13	50 ±0,6	7.5	13	4	13	45.5	53 0/+1,6
63 mm	16	8.5	6.7	M8	13	62 ±0,7	8	18	12	21	49	57 0/+2
80 mm	20	8.3	8.5	M10	16	82 ±0,7	9.5	18	16.5	25.5	54.5	64 0/+2
100 mm	25	9.7	8.5	M10	21	103 ±0,7	10.5	20	20	29	66.5	77 0/+2

- 1) Min.
- 2) Option: through piston rod
- S = stroke

## Diagrams

### Maximum admissible lateral force static

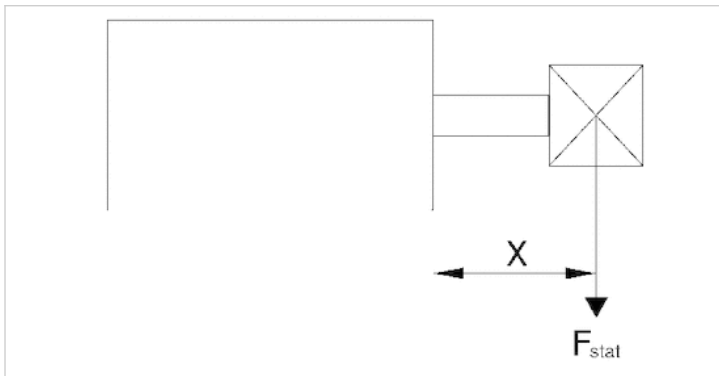

$F_{stat}$  = static lateral force  
 $X$  = distance between force application point and cylinder cover

Maximum admissible lateral force static

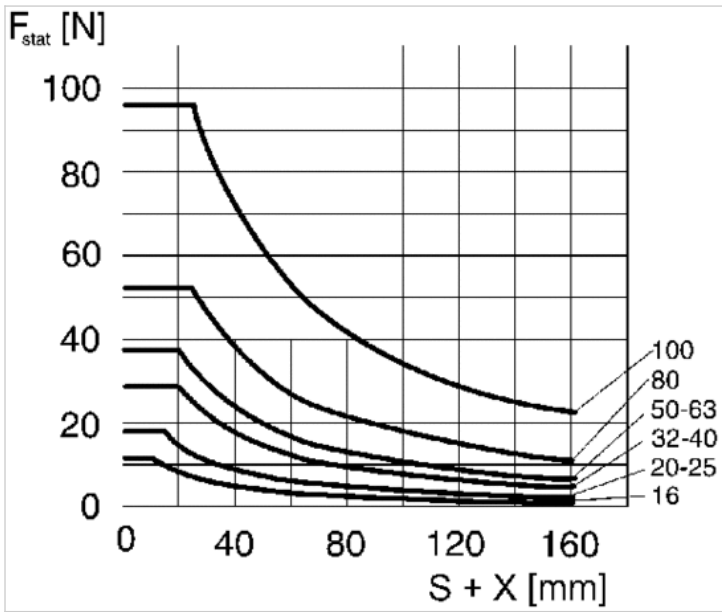

F stat. = static lateral force  
 X = distance between force application point and cylinder cover  
 S = stroke

Maximum admissible lateral force dynamic

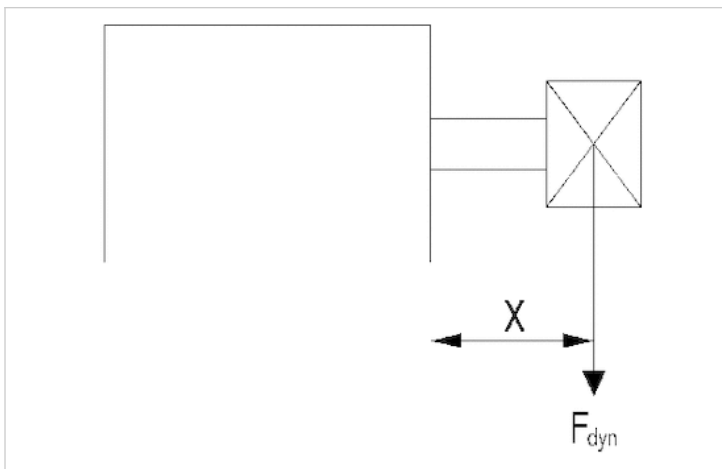

F dyn. = dynamic lateral force  
 X = distance between force application point and cylinder cover  
 S = stroke

Maximum admissible lateral force dynamic

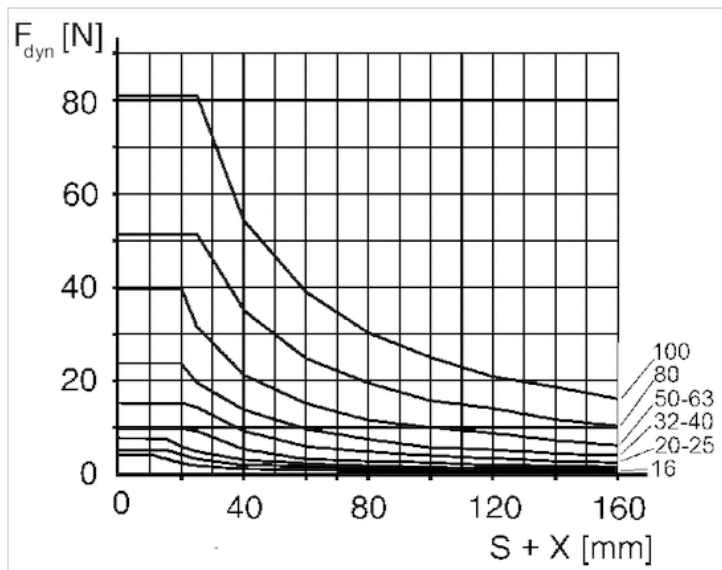

$F_{dyn}$  = dynamic lateral force  
 $X$  = distance between force application point and cylinder cover  
 $S$  = stroke

## Accessories overview

### Overview drawing

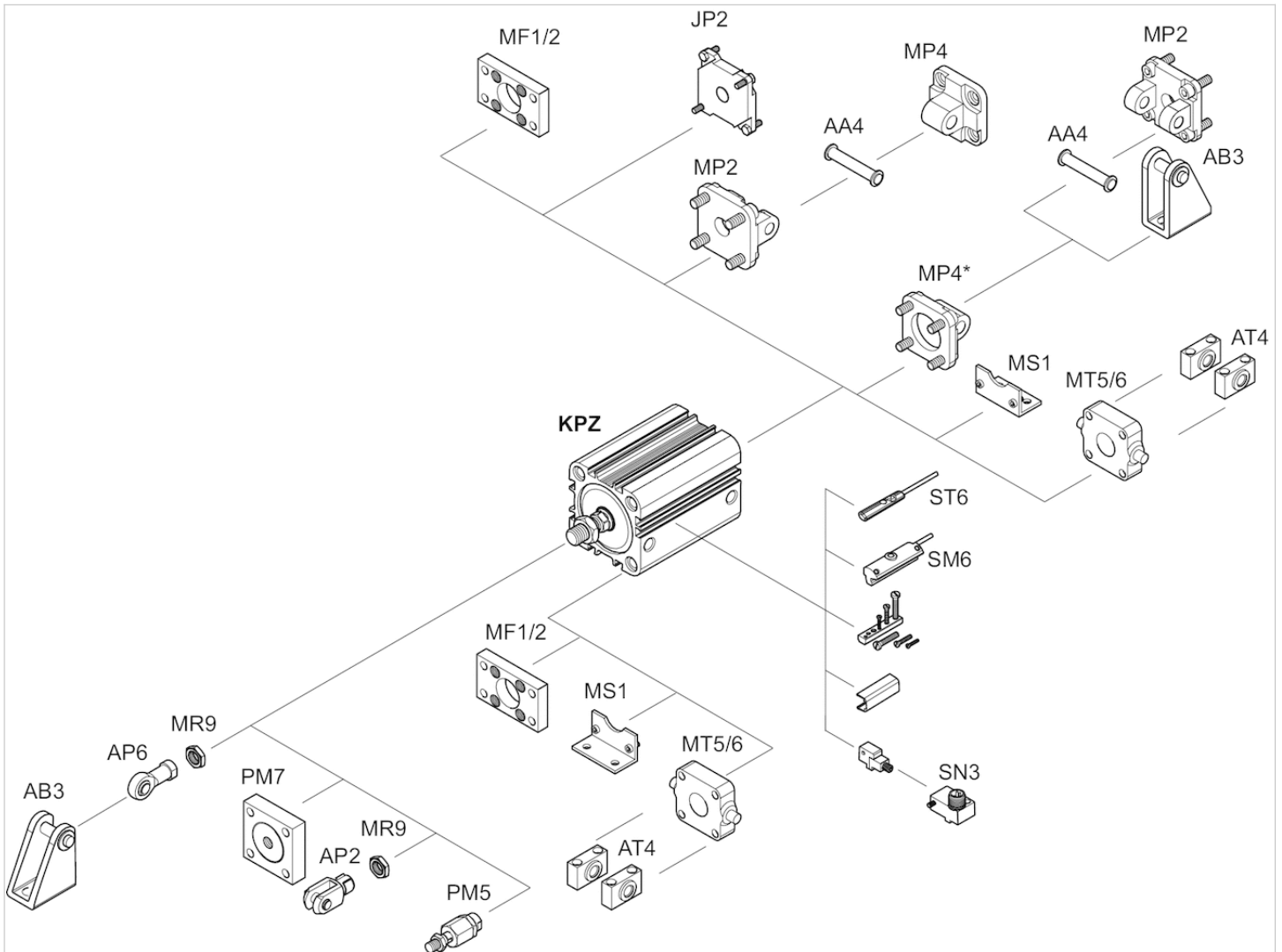

\* Available for installation on KPZ for cylinder diameters 16 - 25 mm

**NOTE:**

This overview drawing is only for orientation to indicate where the various accessory parts can be fastened to the cylinder. The illustration has been simplified for this purpose. It is thus not possible to derive the dimensions from this overview.